

Two-Stage Regenerative Turbine Pump

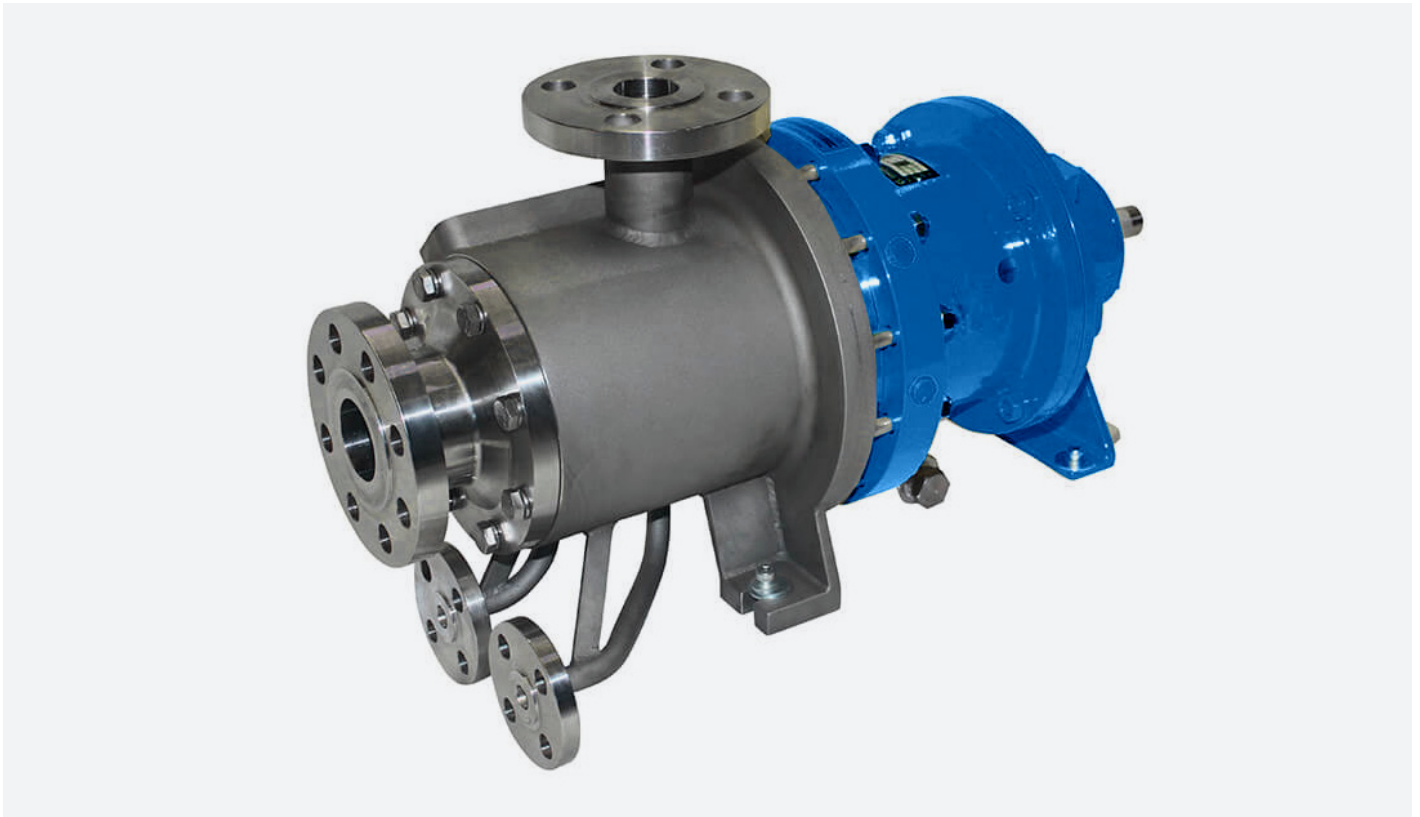

» TECHNOLOGY INNOVATION & RELIABILITY

Our high-performance pump solutions are designed to meet the demands of various fluid-handling applications. Our Two Stage Regenerative Turbine Pumps are engineered with precision and innovation to deliver reliable and efficient performance.

» BENEFITS

NPSH Optimisation: designed with careful consideration of Net Positive Suction Head (NPSH) to prevent cavitation, ensuring prolonged pump life and enhanced reliability

Self-Priming Capability: these self-priming pumps can effortlessly handle air and gases, eliminating the need for manual priming and ensuring quick and reliable operation

Efficient Cavitation Prevention: prevention of cavitation thanks to optimised NPSH levels and advanced design features

Robust Construction: built with durability in mind, featuring robust construction materials such as Stainless Steel to withstand challenging operating conditions and ensure a long service life

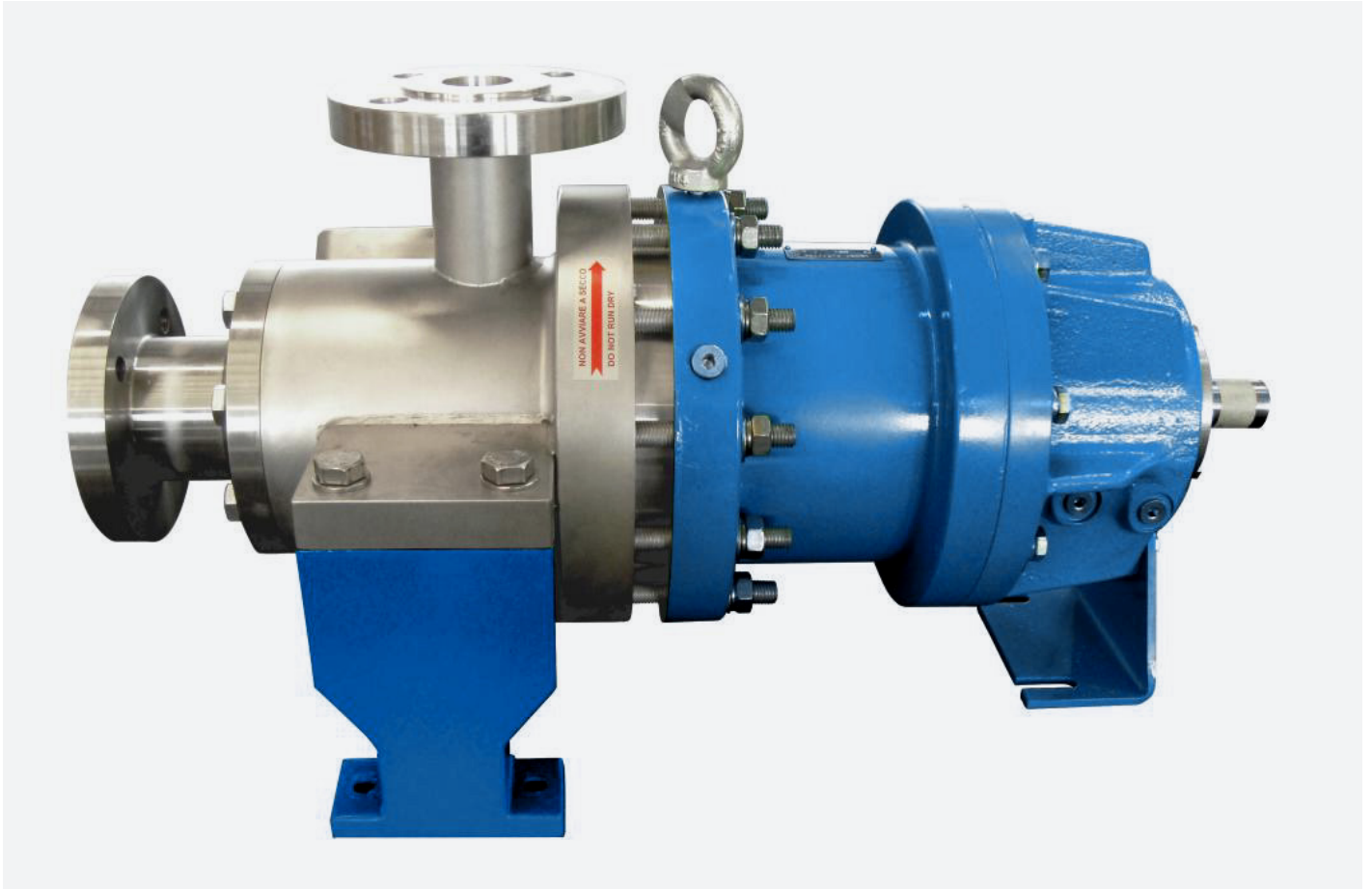

» HIGH HEAD - LOW NPSH

Suitable for liquefied gas, condensate hydrocarbons, ammonia and cryogenic liquids.

- Flows up to 14m³/hr
- Heads up to 400m
- NPSH required less than 1m
- API 685, barrel type, end suction, top discharge, centreline mounted

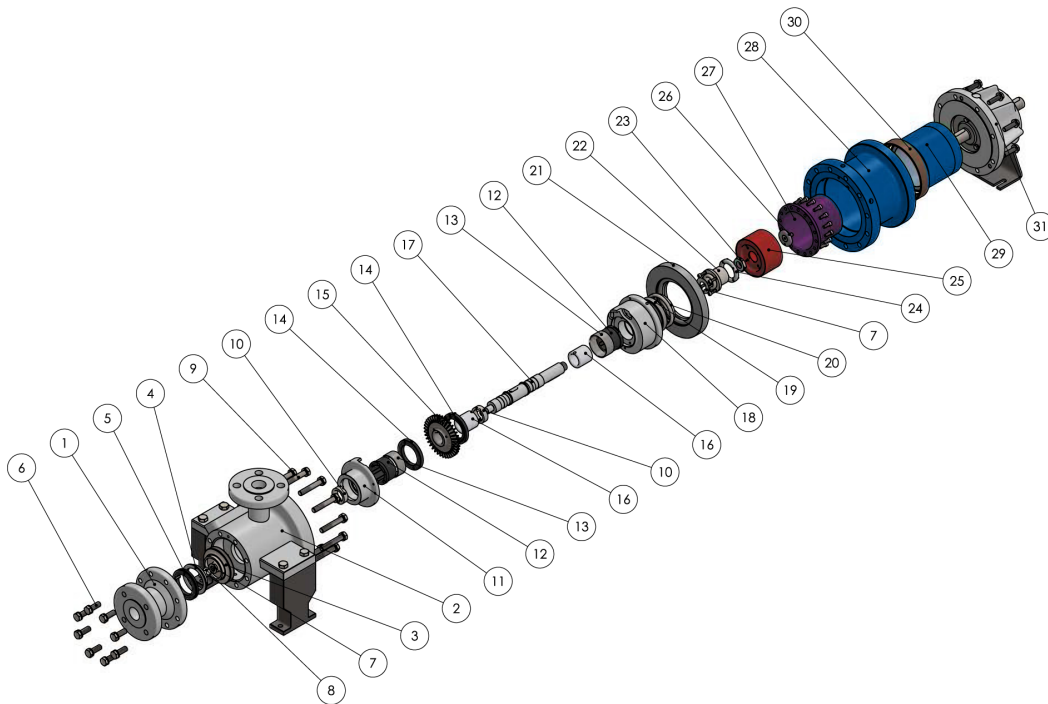

Ref.	Description	Ref.	Description
1	Front flange	17	Shaft
2	Pump casing	18	Rear ring
3	Centrifugal impeller	19	Front conical ring
4	Centrifugal impeller thrust bearing	20	Rear conical ring
5	Front thrust bearing	21	Rear casing adaptor plate
6	Front flange screw	22	Inner magnet ring flange
7	Nut lockwasher	23	Rear nut
8	Ogive	24	Rear impeller ring
9	Pump casing screw	25	Inner magnet
10	Spacer	26	External magnet nut lockwasher
11	Front ring	27	Containment shell
12	Stationary bearing	28	Bracket
13	Stationary bearing ring	29	External magnet ring
14	Thrust bearing	30	Rub ring
15	Turbine impeller	31	Bearing frame
16	Sleeve bearing		

Design Curves

» Alloy Double Stage Turbine Pump
2900 rpm 50hz

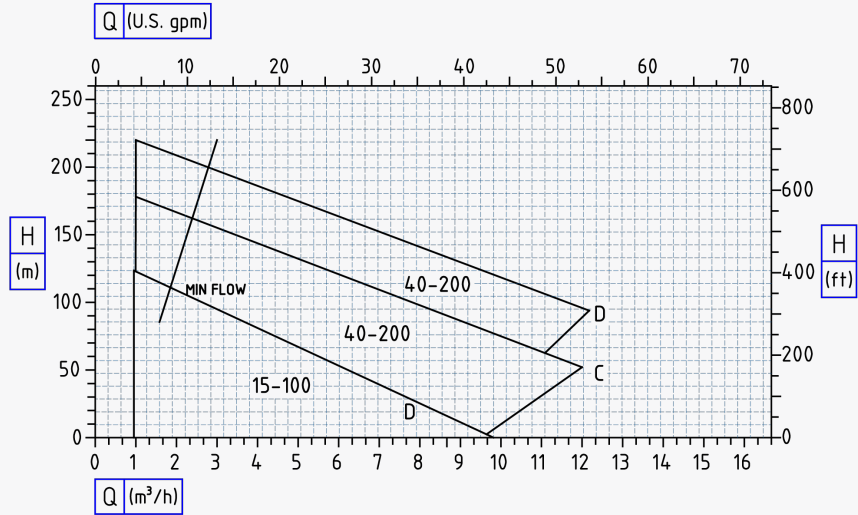

» Alloy Double Stage Turbine Pump
3500 rpm 60hz

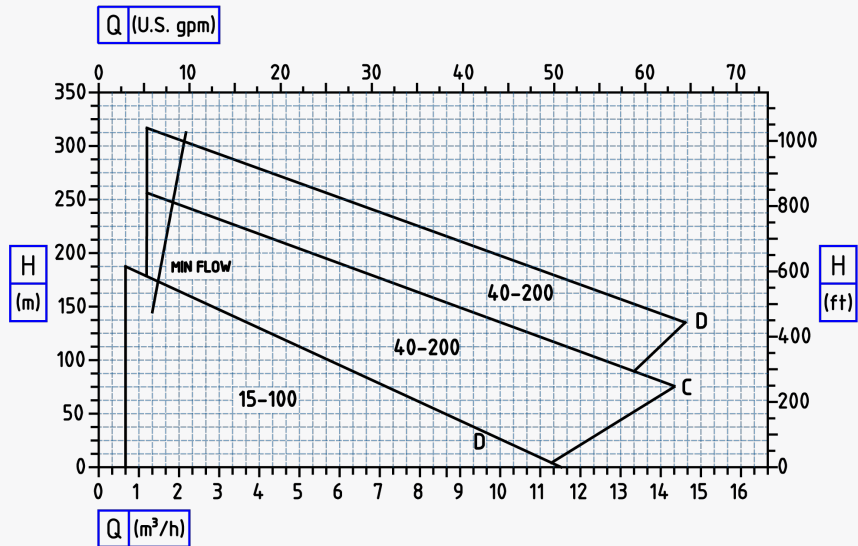

Design Curves

» Alloy Double Stage Turbine Pump
1450 rpm 50hz

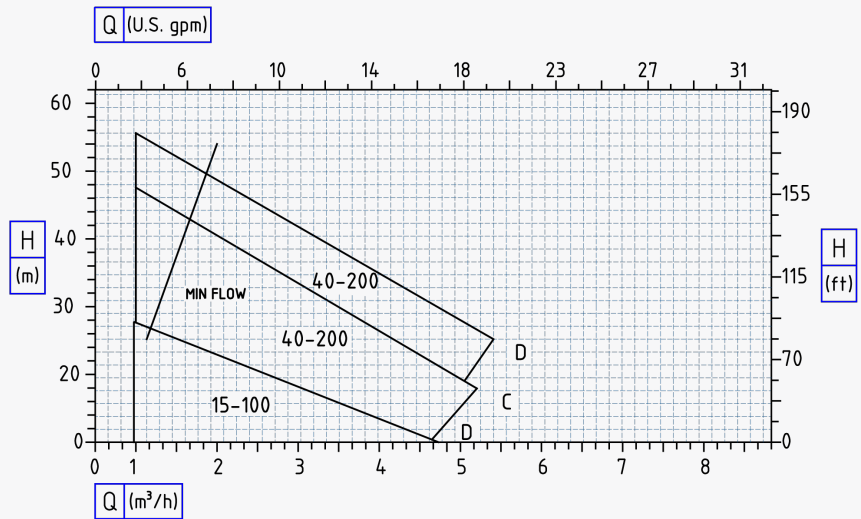

» Alloy Double Stage Turbine Pump
1750 rpm 60hz

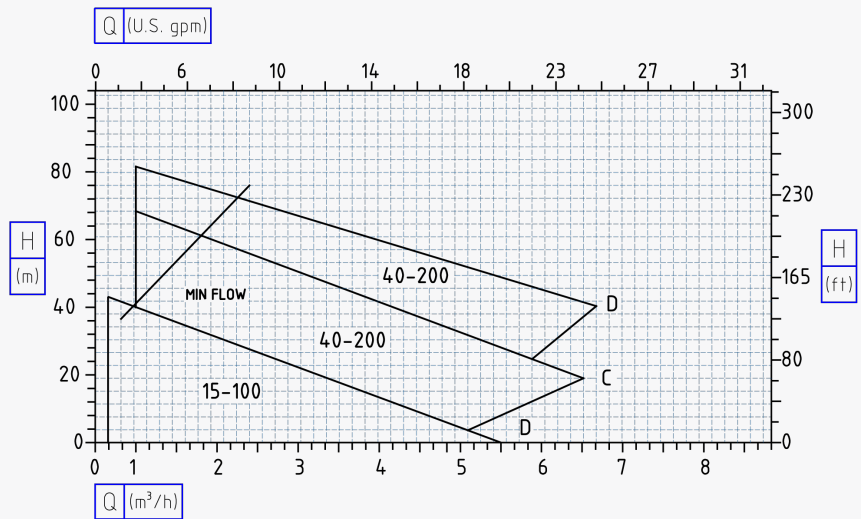

Overall Dimentions

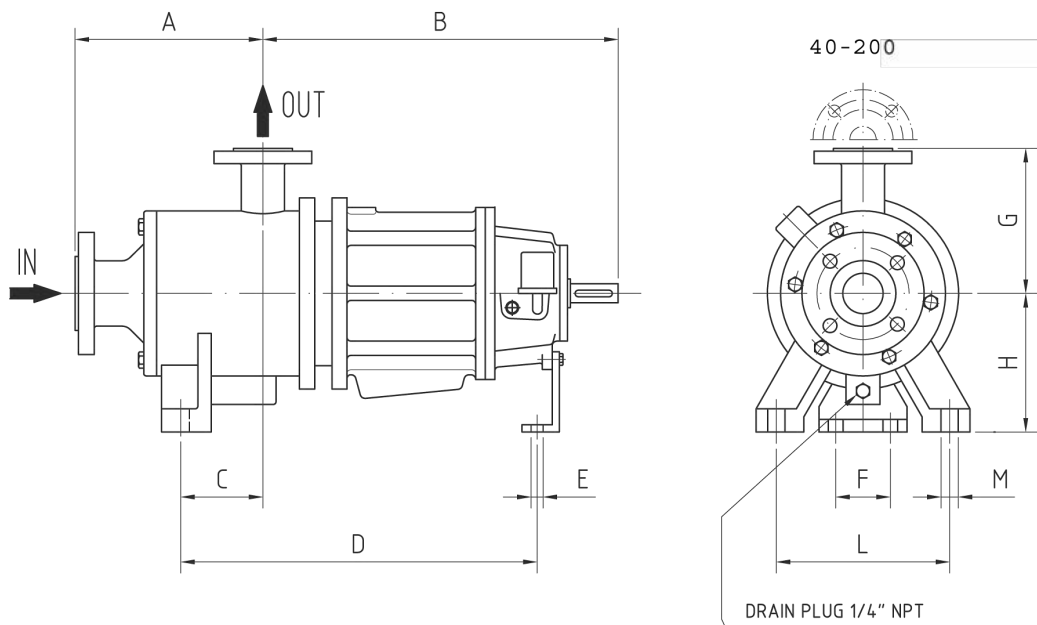
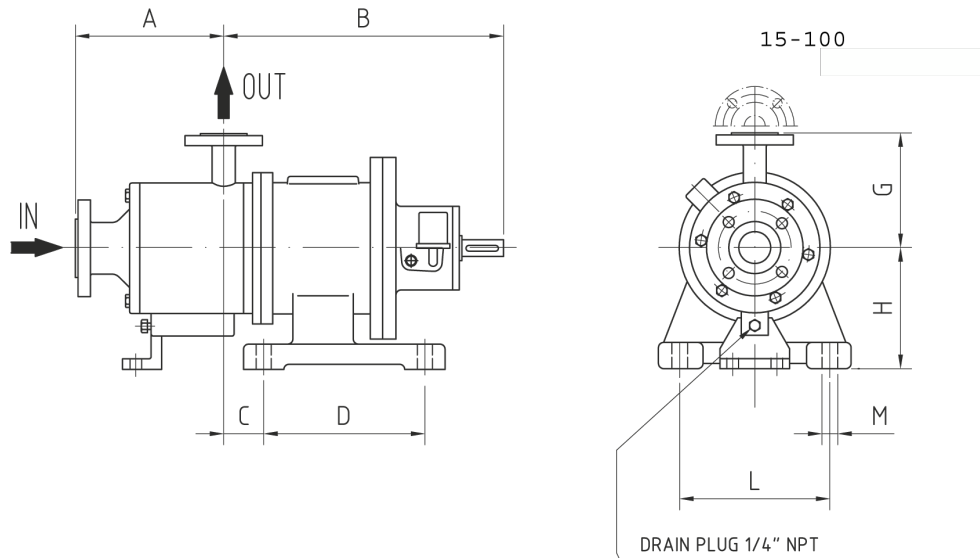

PUMP TYPE	OVERALL DIMENSIONS										PORTS FLG		$\frac{\text{mm}}{\text{inches}}$
	A	B	C	D	E	F	G	H	L	M	SUCT.	DISCH.	WEIGHT
15-100	162	395	56	250			135	175	220	14	DN 40	DN 25	40 kg
	6 ³ / ₈	15 ¹ / ₂	2 ¹ / ₄	9 ⁷ / ₈			5 ³ / ₈	6 ⁷ / ₈	8 ⁵ / ₈	1/2"	DN 1 ¹ / ₂	DN 1"	88 lbs
40-200	203	536	75	481	14	110	185	160	190	14	DN 50	DN 40	135 kg
	8"	21 ¹ / ₈	3"	19"	1/2"	4 ³ / ₈	7 ¹ / ₄	6 ¹ / ₄	7 ¹ / ₂	1/2"	DN 2"	DN 1 ¹ / ₂	298 lbs

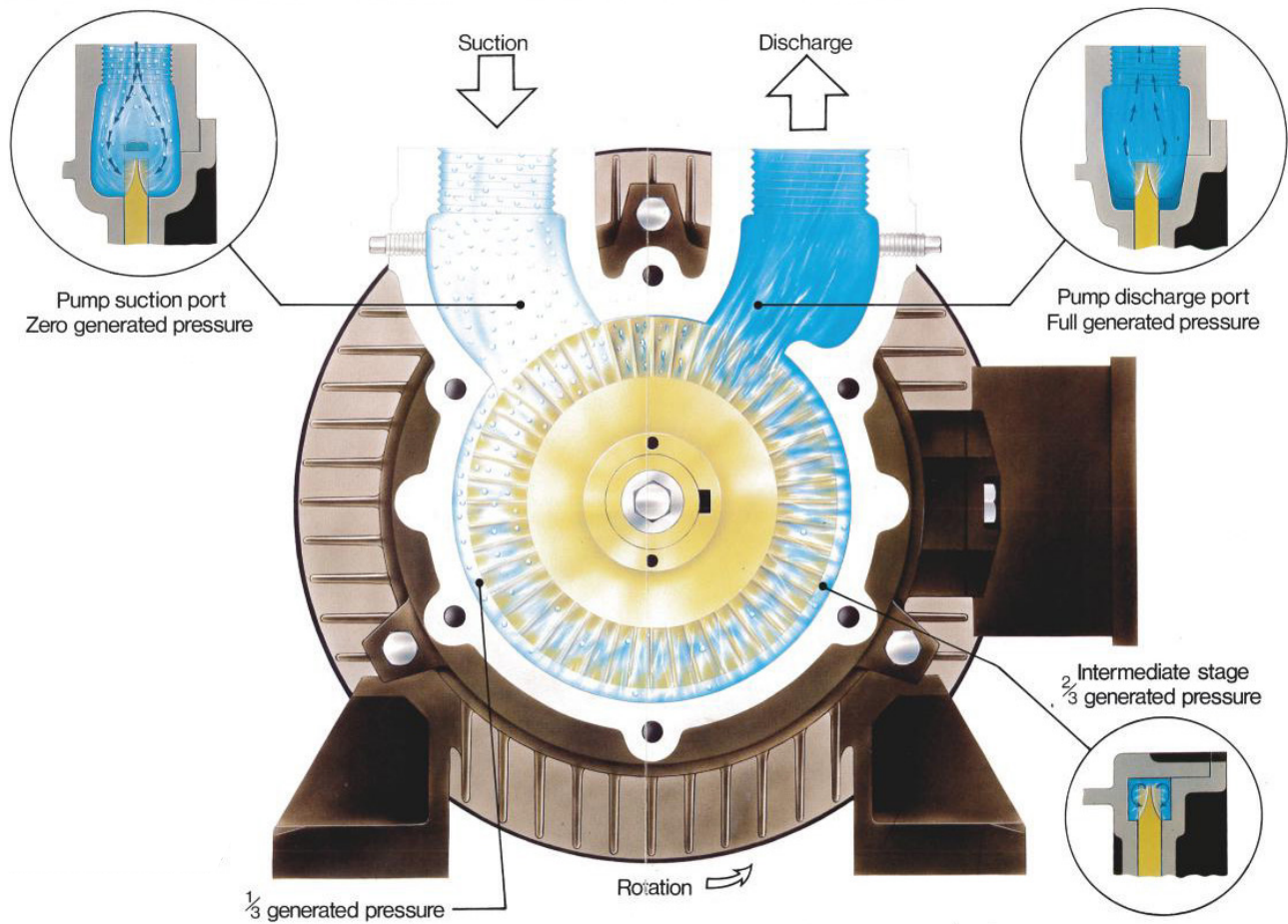

» THE TURBINE REGENERATIVE PRINCIPLE

The regenerative turbine principles deliver efficient and reliable fluid handling. This technology offers a unique approach to fluid circulation, providing significant advantages over traditional Centrifugal Pumps:

Impeller Design:

- The impeller is a critical component designed with a multi-vane construction
- Liquid from the suction port is directed to both sides of the impeller at its perimeter

Centrifugal Force:

- The impeller's multi-vane construction, combined with its rotation, generates centrifugal force
- This force instantly throws the liquid outwards, creating a spiral regenerative action

Suction and Drawing Force:

- As the liquid enters the side channels of the pump casing, a strong drawing force is produced at the pump's suction due to the forward rotation of the impeller
- The liquid is rapidly returned to the root of the next impeller vane, initiating further re-engagement

» REGENERATIVE TURBINE PRINCIPLES

Regenerative Action:

- The regenerative action continues, developing increased pressure with each cycle
- The liquid achieves its fully generated pressure and is sealed off from the suction side by a breaker, exiting the pump at the discharge port

Double-Faced Impeller:

- Each impeller is double-faced, enabling regenerative action on both sides
- This inherent balance contributes to a smooth and efficient pumping process.

Fluid Circulation:

- Fluid circulates through the impeller vanes multiple times, creating a circulatory flow
- This orderly flow generates fluid velocity, which can be converted into flow and pressure

Regeneration Cycle:

- The fluid, redirected by specially shaped fluid channels, cycles around the side of the impeller and re-enters the impeller vanes
- The regeneration cycle occurs many times, amplifying fluid velocity and pressure

Pressure Building Capability:

- The regenerative turbine design results in a pump with a pressure-building capability ten or more times that of a Centrifugal Pump with the same impeller diameter and speed

Impeller Floating Design:

- Our pumps feature a two-sided floating impeller design, ensuring pressure is built equally on both sides
- This design allows the pump pressure to hydraulically self-centre the impeller in the close clearance impeller cavity, avoiding excessive loads on motor bearings

Internal Clearances:

- Close internal clearances are maintained to prevent the loss of pressure-building capability
- These pumps are suitable for clean fluids and systems, and in some cases, a suction strainer can be employed for added protection

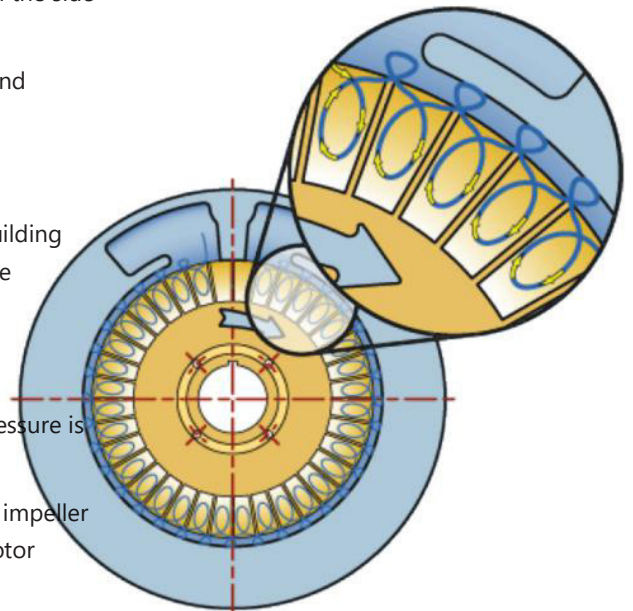
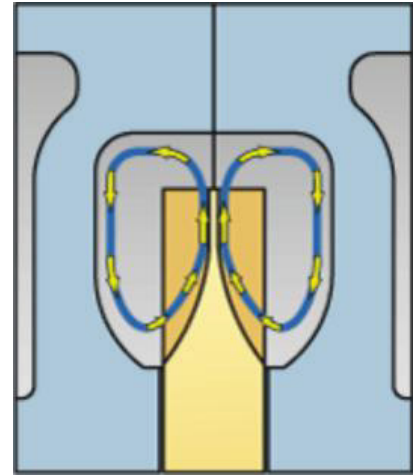

» DOUBLE STAGE, LONG COUPLED CONFIGURATION

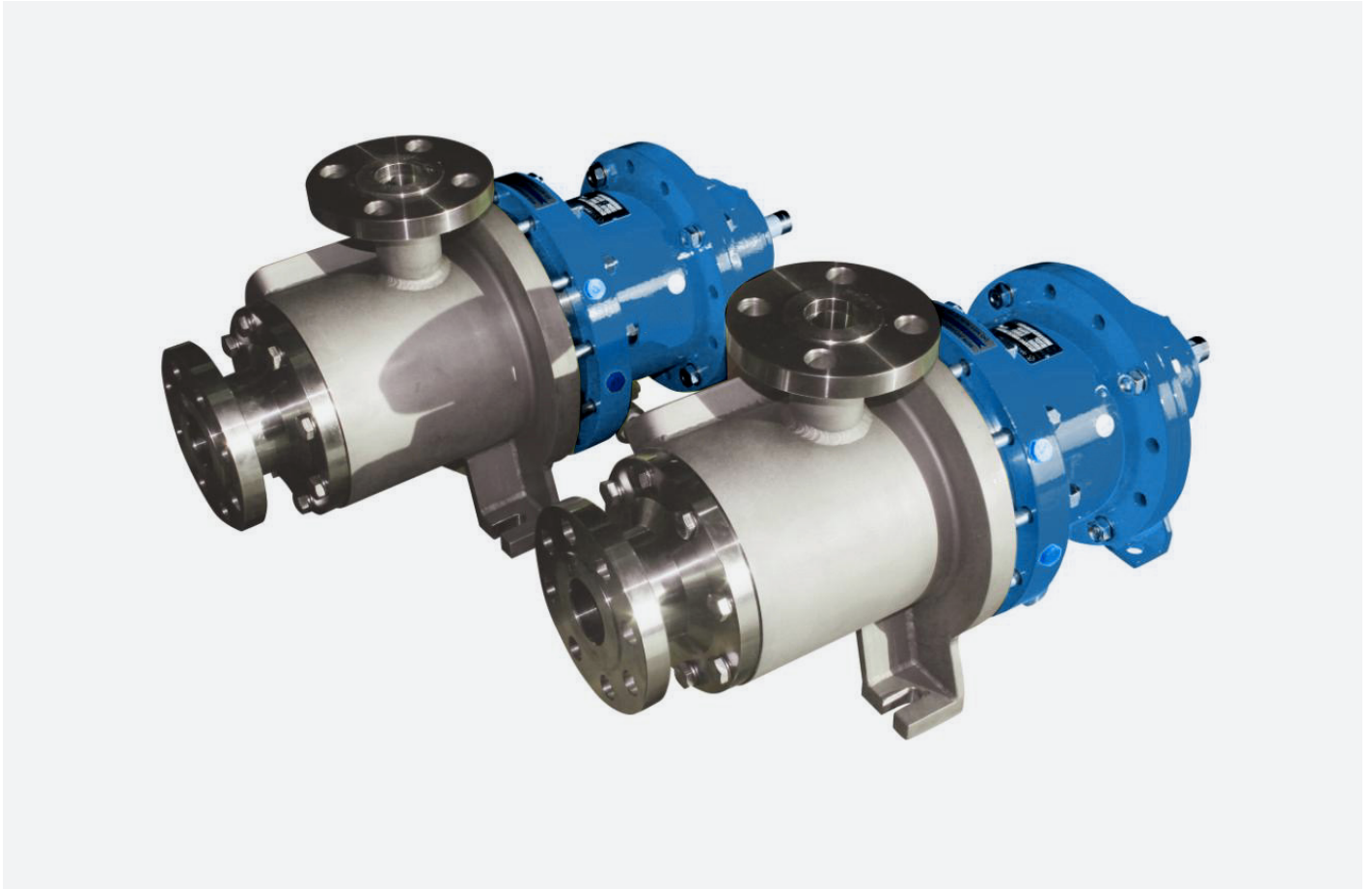

Double-Stage Long-Coupled Configuration is suitable for specific applications requiring a long-coupled design.

- API685 Standards compliance
- Double containment shell with a mechanical seal on the coupling housing
- NPSHa: 1.5m