

English

MODELS

TPUK-MDU200

topflo[®]
pumps & systems



Operation & Maintenance Manual

MOBILE DECANTING TROLLEY
FOR 200 LITRE CONTAINERS



Instructions for the installation, start-up, operation, maintenance and repair



Spare parts



Read this instruction manual carefully before you install and operate this system!

Contents

Page	Section	Sub-section
3	CE Certificate	
4	Introduction	
	Warning symbols	
	Receiving inspection	
	Storage	
5	Mounting	
	Air connections	
	Air preparation	
	Air pressure	
	Health & safety	
	Protection	
	Explosive environments	
6	Principle of operation	Fig.1
7	Key components	Fig.2
8	Filling the integral chemical container	Fig.3
9	Dispensing the chemical	
10	Batcher components	Fig.4
	Set up	
	Setting the predetermining counter	
11	Dry test	
12	Wet test	
13	Tapflo volume per stroke table	Formula.#1
	System test	Formula.#2
	Operation	
	Loss of pressure system	
14	Technical Data	Fig.5
		Dimensions
		Connections
		Specifications
15	Routine maintenance	
	Trouble shooting	
16	Spare parts	
	How to order parts	
	Returning parts	
17	Warranty	
18	Warranty return form	
19	Warranty return form - Sketch of installation	

**EC DECLARATION
OF CONFORMITY**



Name and Address of the manufacturer:	Tapflo (UK) Ltd Highcove House Chandlers Ford Ind Est Hampshire SO53 4BU UK
Description of Equipment:	Pneumatic batch control system Predetermining
Model / Type:	TPUK-MDU200
Directives / Conformity Assessment Procedures:	The Machinery Directive (2006/42/EC) / Non Annex IV Machinery, Self declaration/Technical file
Declaration:	The person signing below declares that the above named equipment fulfils all the relevant provisions of the stated directives.
Place of Declaration	Tapflo (UK) Limited, SO53 4BU, UK
Date:	15/5/2017
Signed:	
Printed Name of Authorised Signatory:	Mr. M. Barnes
Position in Company:	Owner

Introduction

Tapflo (UK) pump control systems are designed to offer simple solutions for industrial pumping applications. The systems work in harmony with each pump application utilising similar means of power and methods of construction to give safe, simple and reliable use.

With proper installation, set-up and maintenance Tapflo (UK) systems give efficient and trouble free operation. This manual will familiarize operators with detailed information about installing, operating and maintenance of the system.

Warning symbols

The following warning symbols are present in this instruction manual. The warning information should be observed when either of these symbols is present.



This symbol highlights all safety instructions in this manual where danger to persons may occur. Observe these instructions carefully and proceed with the utmost caution in these situations. Inform all users of all safety instructions. In addition to the instructions in this manual, the general safety and accident prevention regulations must be observed.



This symbol highlights points in the instruction manual of particular importance for compliance with regulations and directives, for correct work flow and the prevention of damage to, or destruction of the system or its associate equipment.

Receiving inspection

Although every precaution is taken when packing and shipping, please carefully check goods on receipt, ensuring all parts listed on the packing note are accounted for. Report any damage or shortages to the delivery company and Tapflo (UK) within 24 hours of receipt.

Storage



If the equipment is to be stored prior to installation, place in a clean dry location ensuring it is not exposed to extreme temperature or humidity, ideally in original packaging to prevent contaminates entering the system.

Mounting



Tapflo (UK) systems will operate properly without being mounted unless otherwise stated. If the system is to be mounted please ensure the surface is suitable for the load detailed in the specifications and appropriate to the system and application.

Air connections



Please ensure all connections observe the specifications of the system, failure to observe this could result in damage to the system and danger to personnel.

Air preparation



All Tapflo (UK) systems are designed to run on clean, dry air, lubrication is not recommended. Maximum pressure is 7 bar (G) unless otherwise stated. An inline filter of 5 micron or finer is recommended to preserve the life of the system.

Air pressure



The maximum pressure specified in the data section of this manual must not be exceeded. Higher pressures can cause damage and may cause injury to personnel.

Health and Safety



Systems must be installed according to local and national safety rules. The system must be suitable for the application. Failure to do so could result in poor performance and a risk to plant and personnel. Consult Tapflo (UK) if in doubt.

Protection



In the interest of health and safety it is essential to wear appropriate PPE when operating and/or working in the vicinity of the application.

Explosive environments



Tapflo (UK) Ltd systems are not certified for use in explosive environments. Consult Tapflo (UK) for further information. Incorrect installation or use may cause injury or death to personnel in the vicinity of the installation!

Principle of operation

Tapflo (UK)'s mobile decanting system combines a Tapflo air operated diaphragm pump with a Tapflo (UK) Pneumatic Batcher (BP), custom discharge hose with 'shepherd's crook' and purpose designed trolley to accommodate a 200L chemical containers.

The pneumatic batcher is a fully pneumatic predetermining counter system which registers pump strokes via the air exhaust of an AODD pump, stopping the pump once the pre-set number of strokes have been recorded thus controlling the volume of product dispensed by the pump.

The system includes a discharge lance with integral NRV and 'shepherd's crook' for dispensing directly into the points the chemical is required, thus removing the risk of operators carrying buckets of hazardous chemicals that are often in excess of the safe working weights.

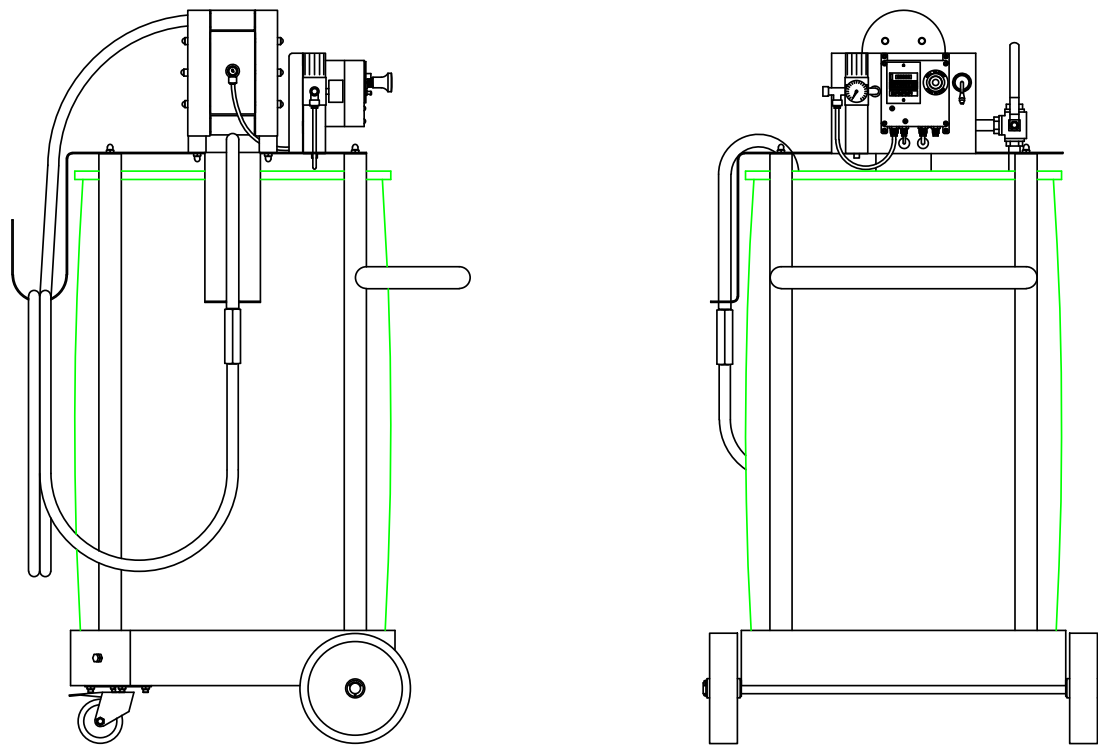

(Fig.1)

Key components

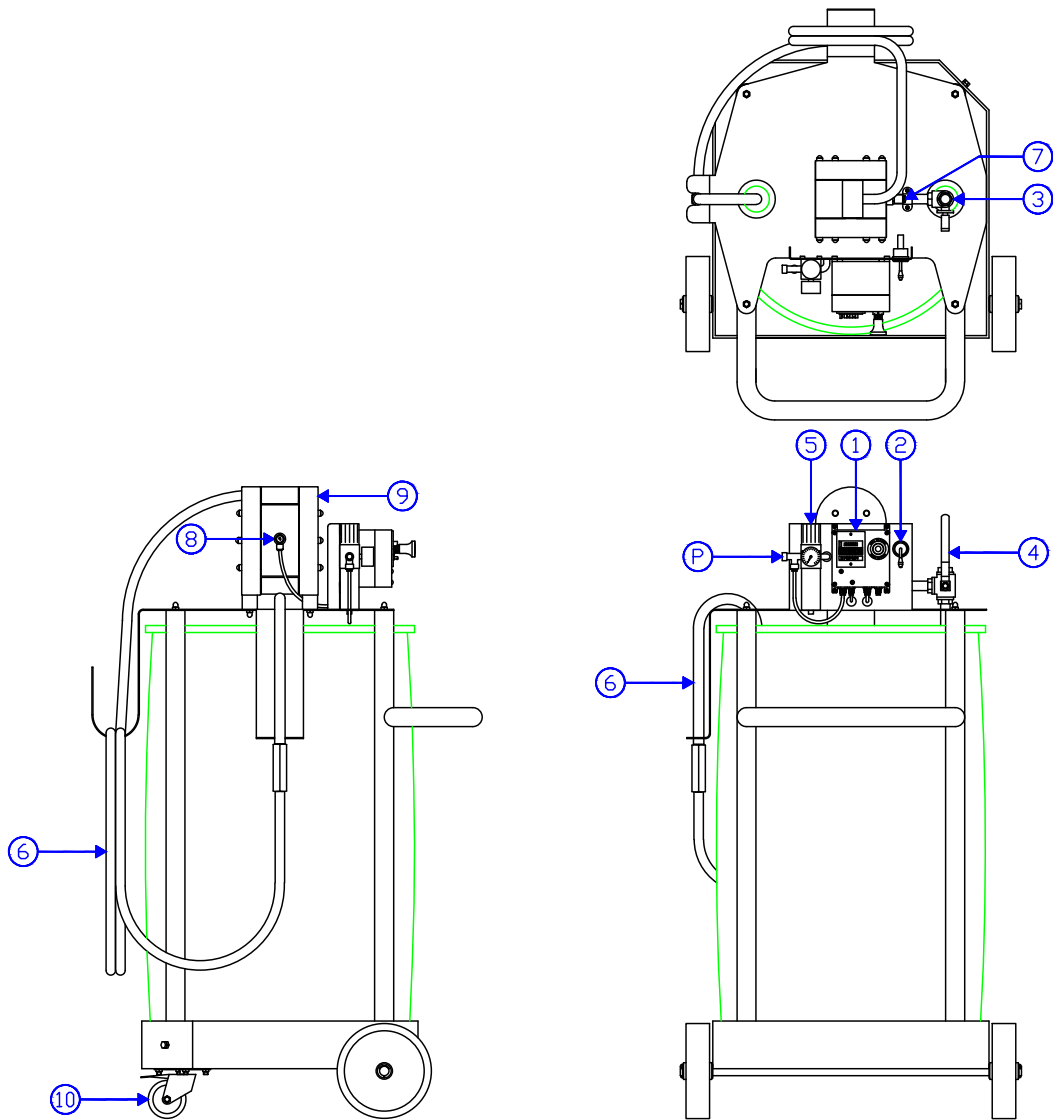

(Fig.2)

Item No.	Description
1	Pneumatic predetermining batch controller (TPUK-BP)
2	Fill mode selection toggle switch
3	Filling suction connection (1/2" BSP-F)
4	Fill mode selection suction valve
5	Pump pressure control
6	Discharge hose with integral NRV and 'shepherd's crook'
7	Pump stroke sensitivity adjustment screw
8	Pump speed control adjustment screw
9	Pump (T50PTT)
10	Locking wheels
P	System air supply connection

Filling the chemical container

Before filling the integral chemical container ensure the following

Risk of product splashing or spill!



- Use appropriate PPE
- The trolley is stably located on a clean, flat surface, with the front wheels locked (Fig.2-10)
- The integral tank is not full
- The 'shepherds crook' is position as shown in fig.3-6
- Observe all prevailing health and safety guidelines

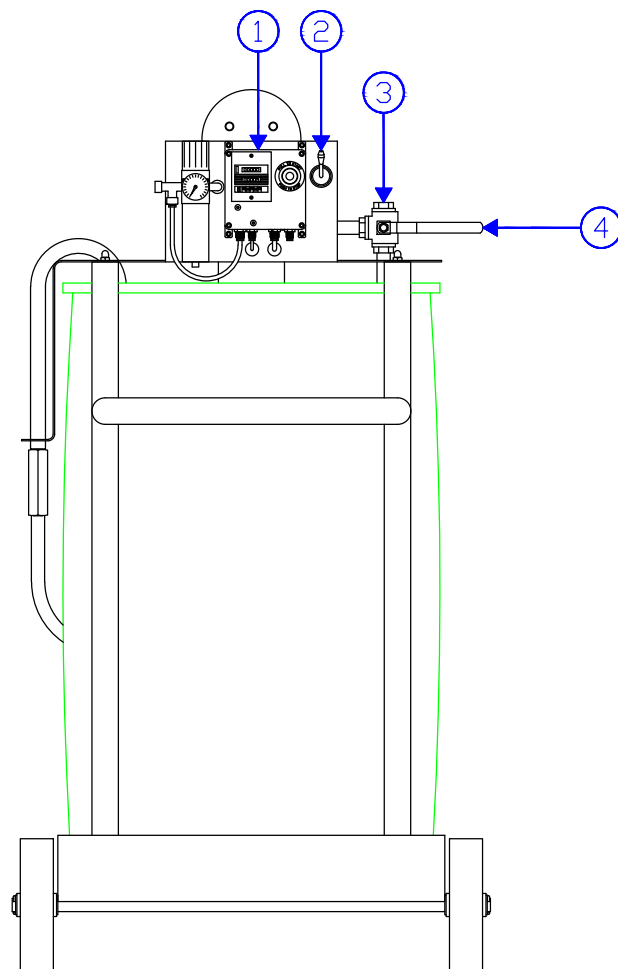

(Fig.3)

Item No.	Description
1	Pneumatic predetermining batch controller (TPUK-BP)
2	Fill mode selection toggle switch
3	Filling suction connection (1/2" BSP-F)
4	Fill mode selection suction valve



Caution - Risk of product splashing or spill!

- Ensure the 'shepherds crook' is position as shown in fig.3
- Do not overfill the tank

To load a chemical container

1. Ensure the shepherds crook (Fig.2-6) is in position as shown.
2. Connect the filling suction (Fig.3-3) 1/2" BSP-F.
3. Position Fill mode selection toggle switch (Fig.3-2) in the up position.
This prevents the batcher from counting and allows the pump to be run under manual control.
4. Position the fill mode suction valve (Fig.3-4) to position as shown in Fig.3.
5. Connect compressed air supply to P port (Fig.2.P)
6. Pull the start/stop valve (Fig.4-1) on the front of the batcher (Fig.3-1) and the pump should begin to run. This will suck product from the source to the integral chemical container via the 'shepherd's crook' and fill the container.



Caution – Risk of spill!

- Residual chemical in filling connection.

Once the container has sufficient chemical in the integral tank.

7. Push the start/stop valve (Fig.4-1) on the front of the batcher (Fig.3-1) and the pump will stop.
8. Reposition the Fill mode selection toggle switch (Fig.3-2) to the down position (Fig.2-2).
9. Reposition the fill mode suction valve to position as shown in Fig.2.
10. Disconnect the filling connection.

Dispensing the chemical

The chemical is dispensed using the integral pneumatic batcher TPUK-BP (Fig.1-1). The following text explains how to use the batcher to dispense controlled amounts of media.

Batcher components

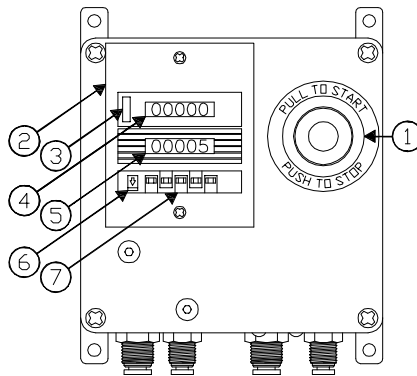

(Fig.4)

Item No.	Description
1	Start/stop-push/pull valve and visual indicator
2	Predetermining counter
3	Counter reset button
4	Actual value (pump strokes)
5	Preset value (pump strokes)
6	Preset value adjustment lever
7	Individual digit preset adjustment push buttons (x5)

Set up

Before using the system ensure the following



- The system is configured correctly and has not been modified.
- Make all connections as instructed.
- Set the air pressure.
- Turn the compressed air supply on.
- Check for leaks. (N.B. the system utilizes an 'air bleed' design and discharges a small amount of air during normal use).
- The system is located on a clean, flat surface.

Setting the predetermining counter

To program the lower 'preset value' (5-fig.4) to the required number strokes, each digit of the 'predetermining counter' (2-fig.4) can be set independently.

1. Push the white preset value adjustment lever (6-fig.4) as shown by the arrow and hold it.
2. Set the desired value with the corresponding preset push buttons (7-fig.4).
3. Release white preset value adjustment lever (6-fig.4).

Dry test

This sets the sensitivity of the counting circuit and proves the system.

1. No chemical container should be fitted.
2. Using a flat bladed screwdriver turn the “pump speed control adjustment screw” (4-fig.1) fully clockwise.
3. Using a flat bladed screwdriver turn the “pump stroke sensitivity adjustment screw” (3-fig.1) fully clockwise.
4. Set the predetermining counter (2-fig.4) to 00010 as described in “Setting the predetermining counter (2-fig.4)’ section above.
5. Turn ‘on’ the compressed air supplies P.
6. Pull the start/stop-push/pull valve (1-fig.4), nothing should happen.
7. Using a flat bladed screwdriver slowly turn the “pump speed control adjustment screw” (4-fig.1) counter-clockwise until the pump is running at a controlled rate. The counter should not be counting.
8. Using a flat bladed screwdriver slowly turn the “pump stroke sensitivity adjustment screw” (3-fig.1) counter-clockwise until the predetermining counter (2-fig.4) begins to count. After the 10 strokes are recorded the pump will stop.
9. Pull the start/stop-push/pull valve (1-fig.4), and the pump should start and the counter should count each stroke cleanly, stopping the pump once 10 strokes are recorded.
10. Repeat this test adjusting the settings as per steps 7-9 if necessary.

Wet test



The system is best set using the media to be batched, however for safety reasons Tapflo (UK) recommend the system is wet tested with water first, then recalibrated once the whole pump system is installed and tested.

1. Load a chemical container ideally filled with water.
2. Set the predetermining counter (2-fig.4) to 00010 as described in “Setting the predetermining counter (2-fig.4)’ section above.
3. Turn on the compressed air supplies P & P1 (fig.2/3)
4. Prime the system by repeatedly running the pump until media is discharged and no air is present.
5. If necessary, using a flat bladed screwdriver slowly adjust the “pump speed control adjustment screw” (4-fig.1) until the pump is running at the desired flow rate.

6. Check the predetermining counter (2-fig.4) is counting cleanly, if not using a flat bladed screwdriver slowly turn the “pump stroke sensitivity adjustment screw” (3-fig.1) until the predetermining counter (2-fig.4) is recording the stokes cleanly. (N.B. if the pump is running too fast the batcher can struggle to record strokes accurately. If so reduce the pump speed by repeating step 5-6 until the strokes are recorded accurately)
7. Install or position a means of capturing the discharged media such as a suitable container.
8. Pull the start/stop push/pull valve (1-fig.4), and the pump should start and the counter should count each stroke cleanly, stopping the pump after 10 strokes are recorded.
9. Measure the volume of discharged media and using ‘Formula.#1’ work out the displacement per stroke.

$$\text{Formula.\#1} : \frac{\text{Displaced volume (litres)}}{\text{Number of stokes (10)}} = \text{Volume in litres / stroke}$$

10. Repeat steps 7-9 to ensure the accuracy of the above calculation, obtaining an average over several runs.
11. To calculate the number of strokes to give a set volume use ‘Formula.#2’ to work out the number of stokes required for a specific batch volume.
12. To calculate the number of strokes to give a set volume use ‘Formula.#2’ to work out the number of stokes required for a specific batch volume.

$$\text{Formula.\#2} : \frac{\text{Batch volume (litres)}}{\text{Volume per stroke (litres/stroke)}} = \text{Number of stokes}$$

13. Set the predetermining counter preset value (5-fig.4) to the number of stokes calculated in ‘Formula.#2’, as described in “Setting the predetermining counter (2-fig.4)’ section.
14. Run a test cycle checking the dispensed volume is correct.
Due to compound errors it is often necessary to adjust the number of stokes to give the exact dispensed volume for larger batch sizes.
15. If the correct volume has been dispensed the batcher is calibrated.
16. BPI version – Replace the enclosure lid, ensuring no pipes are trapped
17. If the incorrect volume has been dispensed repeat this section.

Tapflo pump volume per stroke table (mL / cu in)

Alternatively the following table can give approximate guidance to the volume per stroke. Using ‘Formula.#2’ to calculate the estimated number of stokes for a given batch size.

Plastic series		Metal series		Hygienic series	
TR20	50 / 3.05	T25	70 / 4.27	T30	70 / 4.3
T50	120 / 7.32	T70	87.5 / 5.34	T80	140 / 8.5



- The values are for reference only.
- All values were accurate at the time of print.
- All values obtained from Tapflo IOM manuals (09/11).
- The values above are based on EPDM diaphragms. Pumps with PTFE diaphragms reduce the volume by approximately 15%

System test



Once the system is fully installed and the media is primed, run some test cycles to confirm the calibration, adjusting the predetermining counter to trim the batch size.

Operation

Risk of product splashing or spill!



- Ensure pump discharge is positioned correctly to capture the discharged media.
- Use the correct PPE
- Use a bund if discharging into small containers

To dispense a batch, pull the start/stop-push/pull valve (1-fig.4).

- Pump will start and media is dispensed.
- Once the number of stokes recorded equals the number in the 'preset value (pump strokes)' shown on the display (5-fig.4) the pump will stop.
- The dispensed batch will be as per the calibration.

To stop the pump mid-batch, press the start/stop-push/pull valve (1-fig.4).

- Pump will stop immediately
- Number of recoded stokes will reset to 00000

Loss of pressure start-up system

The batcher is equipped with a loss of pressure automatic reset system. If the compressed air supply (P) is removed the start/stop-push/pull valve (1-fig.4) will automatically reset to the 'off' position.

Technical data

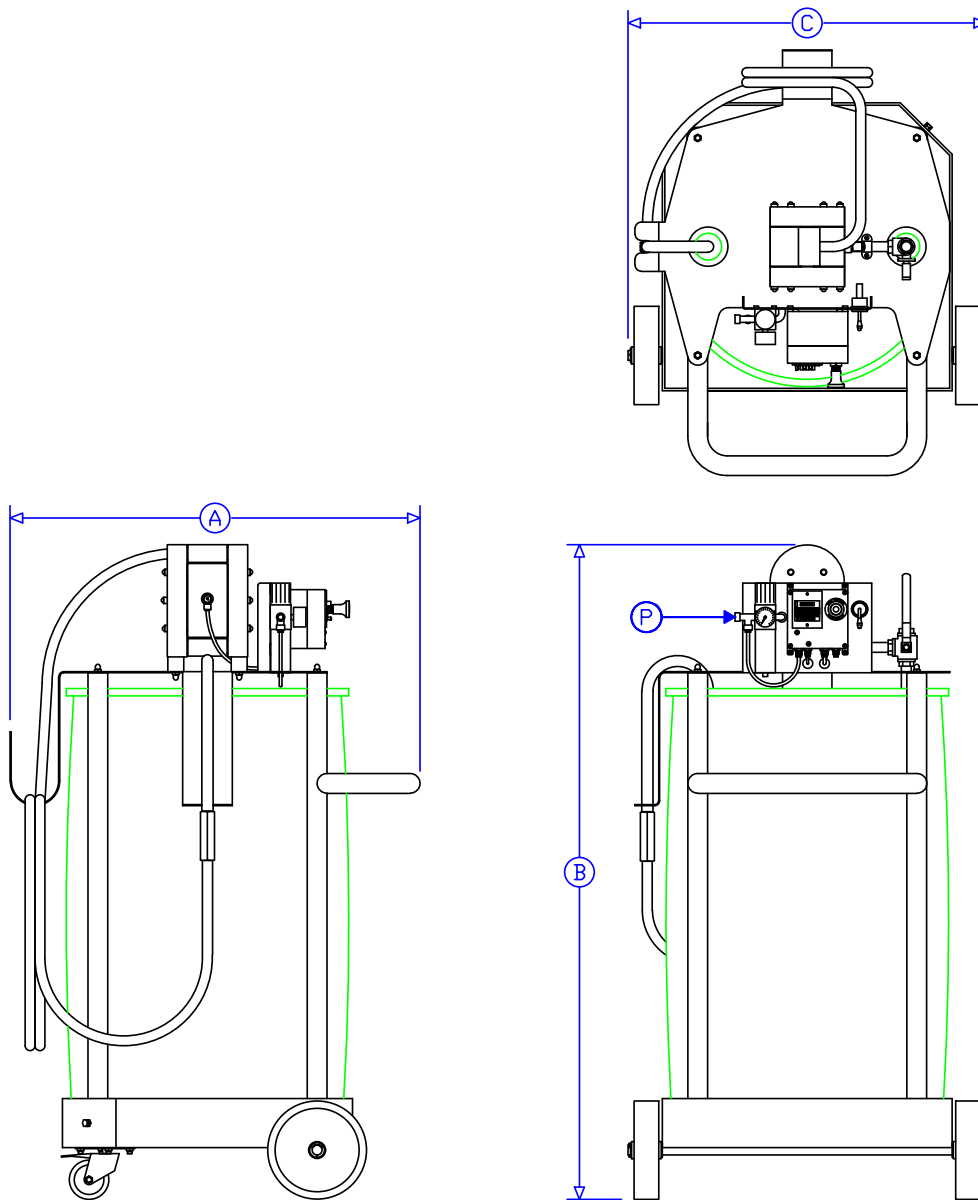

(fig.5)

Dimensions					
A	830 mm	B	1330 mm	C	725 mm

Connections		
Port No.	Description	Connection type
P	Air supply	1/4" BSPF Female

Specifications	
Temperature range – Ambient	0°C to +40°C
Air pressure – Min/Max	4-7 BAR (G)
Weight (empty)	

Routine maintenance

- Pump should be maintained as per the pump specific documentation as per the Tapflo website www.tapflopumps.co.uk
- Routinely check the function and calibration, as normal wear can affect performance. To re-calibrate; follow the instructions in the application specific sections of this manual.
- Check the discharge hose for any signs of damage/leakage, replace as necessary.

Trouble shooting

Check the system is configured as shown in the recommended configuration then see possible solutions below. If the problem persists consult Tapflo (UK).

Please refer to the pump manual for more detail specific to pump issues.

Symptom	Cause	Remedy
System inoperative	Insufficient air supply.	Check all incoming air supplies are connected and meets minimum requirements.
	Speed control adjusted to closed position.	Adjust the speed control (4-fig.1).
	Blocked muffler	Replace and reset muffler (3-fig.1)
	Damaged interconnection	Check and repair any blocked or damaged interconnections
	Control system is out of calibration.	Check calibration as detailed in this O&M manual
	Pump issue.	See pump O&M manual.
	Blocked suction	Check and/or replace suction
Inconsistent batch sizes	Pump issue	Refer to pump manual
	No media	Ensure pump suction is immersed throughout the batch
	Fluctuating air supply	Check all incoming air supplies are connected and meets minimum requirements. Fit regulator.
	Leaking suction connections	Check and remake any damaged or leaking interconnections

Spare parts



- Pump are detailed in the pump specific documentation as per the Tapflo website www.tapflopumps.co.uk
- There are no user serviceable parts within the Batcher - Please consult Tapflo (UK) for service.
- Other spares are detailed below

Quantity	Description	Part number
1	Pump	T50PTT
1	Hose assembly - DISCHARGE	TPUK-DISCHARGE
1	Hose assembly - SUCTION	TPUK-SUCTION
1	Pneumatic predetermining batcher	TPUK-BP
1	Muffler with connection and adjustment	TPUK-MU-1/2
1	Combined blocking/needle valve	TPUK-B/NV-1/4

How to order parts

When ordering parts for Tapflo (UK) system, please provide the model number and serial number of the system, position number and quantity of items required.

Returning parts

To return parts to Tapflo (UK) please follow this procedure.



- Consult Tapflo (UK) for shipping instructions
- Cleanse, neutralise and rinse the part making sure the part is completely free from media
- Provide a certificate of decontamination, where appropriate
- Complete the Warranty / Returns form on following page and return articles carefully to prevent any damage during transport

Warranty

Tapflo UK warrants products under conditions as below for a period of not more than 12 months from installation and not more than 24 months from date of manufacture.

1. The following terms and condition apply to the sale of machinery, components and related services and products, of Tapflo UK (hereinafter "the products")
2. Tapflo UK (the manufacturer) warrants that:
 - a. its products as being free of defects in material, design and workmanship at the time of original purchase;
 - b. its products will function in accordance with Tapflo UK operative manuals; Tapflo UK does not guarantee that the product will meet the precise needs of the Customer, except for those purposes set out in any invitation to tender documents or other documents specifically made available to Tapflo UK before entering into this agreement;
 - c. high quality materials are used in the construction of the products and that machining and assembly are carried out to the highest standards.

Except as expressly stated above, Tapflo UK makes no warranties, express or implied, concerning the products, including all warranties of fitness for a particular purpose.

3. This warranty shall not be applicable in circumstances other than defects in material, design, and workmanship. In particular warranty shall not cover the following:
 - a. Periodic checks, maintenance, repair and replacement of parts due to normal wear and tear (seals, O-rings, rubber items, bushings, etc.);
 - b. Damage to the product resulting from:
 1. Tampering with, abuse or misuse, including but not limited to failure to use the product for its normal purposes as stated at the time of purchase or in accordance with Tapflo UK instructions for use and maintenance of the product, or the installation or improper ventilation or use of the product in a manner inconsistent with the technical or safety standard in force;
 2. Repairs performed by non-skilled personnel or use of non-original Tapflo UK parts
 3. Accidents or any cause beyond the control of Tapflo UK, including but not limited to lightning, water, fire, earthquake, and public disturbances, etc.;
4. The warrantee shall cover the replacement or repairing of any parts, which is documentedly faulty due to construction or assembling, with new or repaired parts free of charges delivered by Tapflo. Parts subjected to normal tear and wear shall not be covered by the warranty. Tapflo shall decide as to whether the defective or faulty part shall be replaced or repaired.
5. The warrantee of the products shall be valid for a period in accordance to the current law from the date of delivery, under the condition that notice of the alleged defect to the products or parts thereof be given to Tapflo UK in written within the mandatory term of 8 days from the discovery.
6. Repair or replacement under the terms of this warranty shall not give a right to an extension to, or a new commencement of, the period of warranty. Repair or replacement under the terms of this warranty may be fulfilled with functionally equivalent reconditioned units. Tapflo UK qualified personnel shall be solely entitled to carry out repair or replacement of faulty parts after careful examination of the pump. Replaced faulty parts or components will become the property of Tapflo UK
7. The products are built in accordance with standard CE normative and are tested (where applicable) by Tapflo UK. Approval and tests by other control authority are for the customers account. The products shall not be considered defective in materials, design or workmanship if they need to be adapted, changed or adjusted to conform to national or local technical or safety standards in force in any country other than that for which the unit was originally designed and manufactured. This warranty shall not reimburse such adaptations, changes or adjustments, or attempt to do so, whether properly performed or not, nor any damage resulting from them, nor any adaptation, change or adjustments to upgrade the products from their normal purpose as described in the products operative manual without the prior written consent of Tapflo UK
8. Installation, including electric and other connections to utility mains according to Tapflo UK drawings, is for the cost and responsibility of the customer, unless otherwise agreed in writing.
9. Tapflo UK will not be liable on any claim, whether in contract, tort, or otherwise, for any indirect, special, incidental, or consequential damages, caused to the customer or to third parties, including loss of profits, arising by any possible infringement of par. 3 above or by the customer or third parties being in the impossibility of using the products.

Notwithstanding the above, Tapflo UK liability to the customer or third parties from any claim, whether in contract, tort, or otherwise, shall be limited to the total amount paid by the customer for the product that caused the damages.

Warranty / return form			
Company			
Address			
Country			
Contact Name			
Telephone		Fax	
E-mail			
Delivery date		Install date	
System Type		Serial No.	
Description of fault			
Media			
Temperature (°C)		Viscosity (cPs)	
Spec. grav. (Kg/m ³)		pH (Value)	
Particle content (%)		Particle size (mm)	
Duty (h/day)		Starts per day (No.)	
Media Pressure (bar)			
Air pressure (bar)		Air quality	
Notes			

Warranty / return form

Sketch of installation

Whilst every effort has been made to ensure that all the information contained in this document is correct at the time of publication, due to our policy of continuous product improvement, the company reserves its right to change any information contained herein without notice.



Tapflo UK Ltd -
Tapflo House, Victory Close, Chandlers Ford, Hampshire SO53 4BU
t: +44 (0)23 8025 2325 f: +44 (0)23 8026 9016
e: sales@tapflopumps.co.uk w: www.tapflopumps.co.uk

DISTRIBUTOR: