

Slurry Horizontal Pump

Handled Liquids

Slurry, highly contaminated, viscous, corrosive and abrasive liquids with solid or fibrous particles.

Technical Data

Discharge Flange _____ DN 25.....DN 350 mm

Capacity _____ up to 3500 m³/h

Head _____ up to 100 m

Temperature Operation _____ -10°C up to +110 °C

Generating Steam Temperature _____ up to 300°C

Note: The Material of pump differs according to the type of pumped liquid, operating temperature and pressure. Contact for detailed information.

Fields of Application

- Mining and mineral processing
- Sand and gravel processing plants
- Abrasive slurry transfer
- Industrial plants
- Pulp and paper industry
- Cyclone feed
- Mine wastes transfer
- Fly ash and bottom ash transport
- Manure transfer
- Lime mud transport
- Waste water systems
- Chemical slurries
- Filter press applications
- Aggregate plants
- Autoclaved aerated concrete plants

Pump Designation

Pump Type _____

Installation Arrangement Horizontally (H) / Vertically (V) _____

Suction Size (DN-mm) _____

Pump Suction / Discharge Size (inch) _____

Pump Material Selection _____

Frame Type _____

SSP - H 80 3/2 HC K



Design Features

- SSP-H pump series are carefully designed by taking into consideration years of production experience of STANDART POMPA and field experiences of our customers using process and slurry pumps. Hydraulic efficiency and hardwearing are considerate and optimised while hard solid particles were pumping.
- SSP-H pump series users are offered with advantages of resistant to extensive wear, high reliability, high hydraulic efficiency, cost effective spare parts and continuous spare part supply in short lead time.

Bearing Design

- SSP-H pump series are produced with extra heavy duty (EHD) design. Grease lubricated bearings of EHD can be replaced with oil lubricated as well.

HORIZONTAL EXTRA HEAVY DUTY SLURRY PUMPS

SSP-H FIELD CHART (HC)

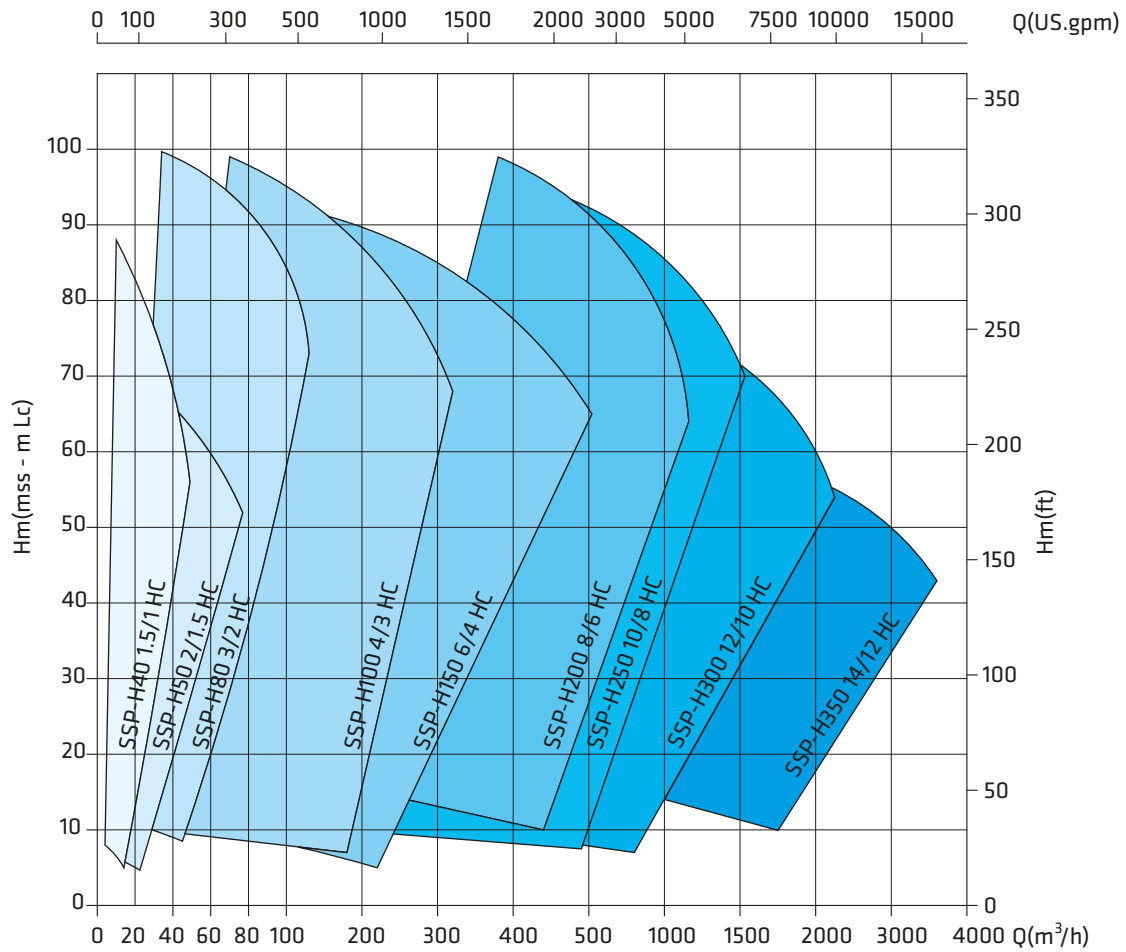

- Impeller and volute of SSP-H HC pumps are high chromium steel casting in standard production. However, different casting material options can be used according to the chemical properties of the fluid.
- SSP-H HC series pump's impeller can be setting with two-way clearance a djustment system.
- There are frame size options for shaft power and applications
- Except H40, H50, H80, H300 and H350, other pumps have 2 different frame sizes according to their motor power.
- In standard production, H 40 an H 50 pumps have open impeller and the others pumps have closed impeller. Pumps with closed impeller can be optionally made as open impeller, vortex impeller or full-recessed vortex impeller.
- Shut-off head is approximately 100m.

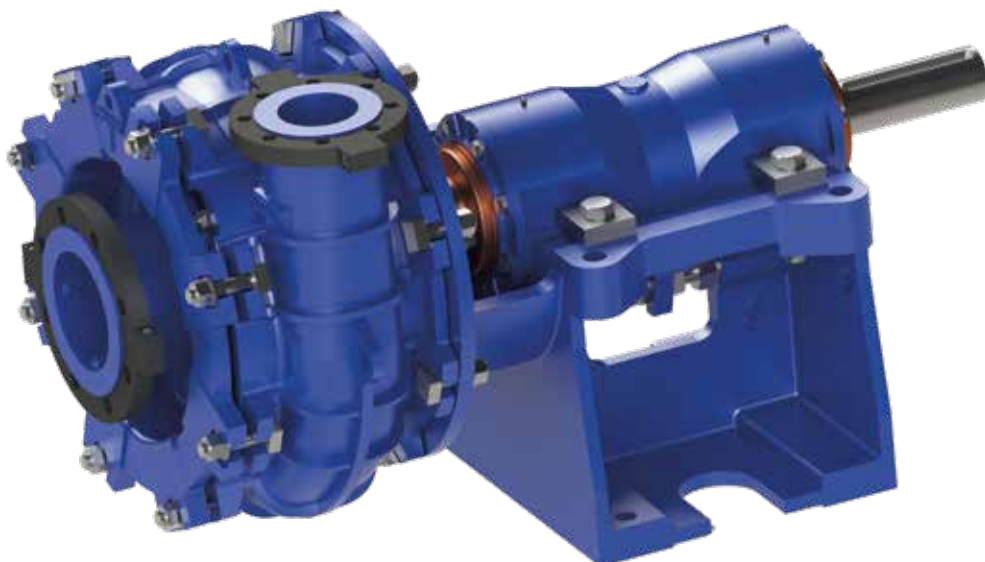

HORIZONTAL EXTRA HEAVY DUTY METAL LINER SLURRY PUMPS

SSP-H FIELD CHART (CHC)

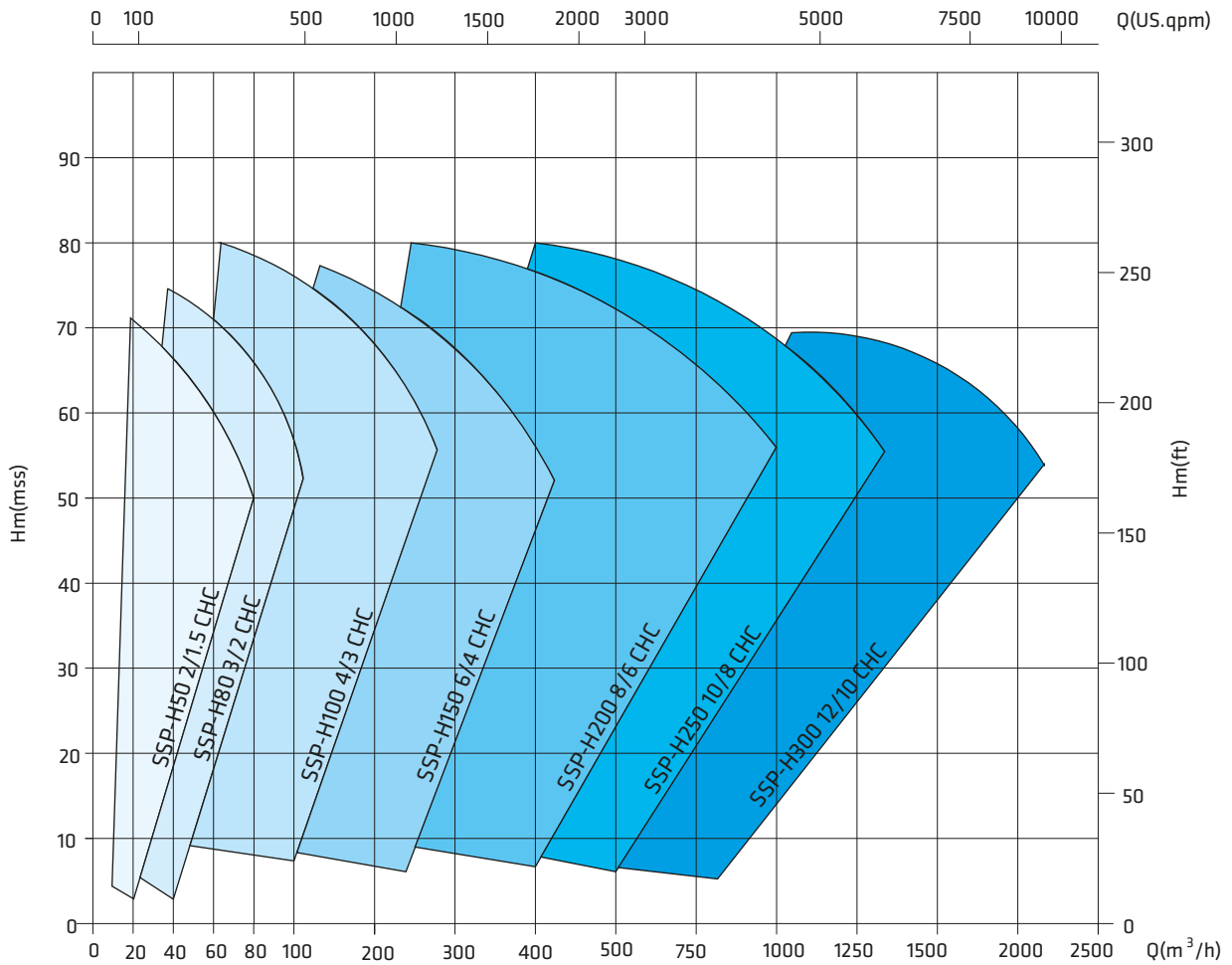

- SSP-H CHC pump series are liner pumps.
- Outer volute is ductile iron with split casing.
- Impeller and volute liner of SSP-H CHC pumps are high chromium steel castings in standard production. However, different casting material options can be used according to the chemical properties of the fluid.
- SSP-H CHC series pump's impeller can be setting with one-way clearance adjustment system.
- There are frame size options for shaft power and applications
- Except H40, H50, H80, and H300, other pumps have 2 different bearing sizes according to their motor power.
- In standard production, H 50 pump have open impeller and the others pumps have closed impeller. Power with closed impeller can optionally be made as open impeller.
- Shut-off head is approximately 80m

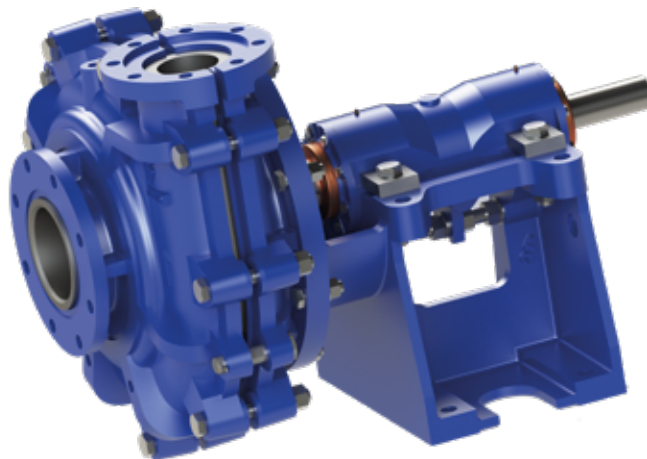

HORIZONTAL EXTRA HEAVY DUTY METAL LINER SLURRY PUMPS

SSP-H FIELD CHART (CHC-HR)

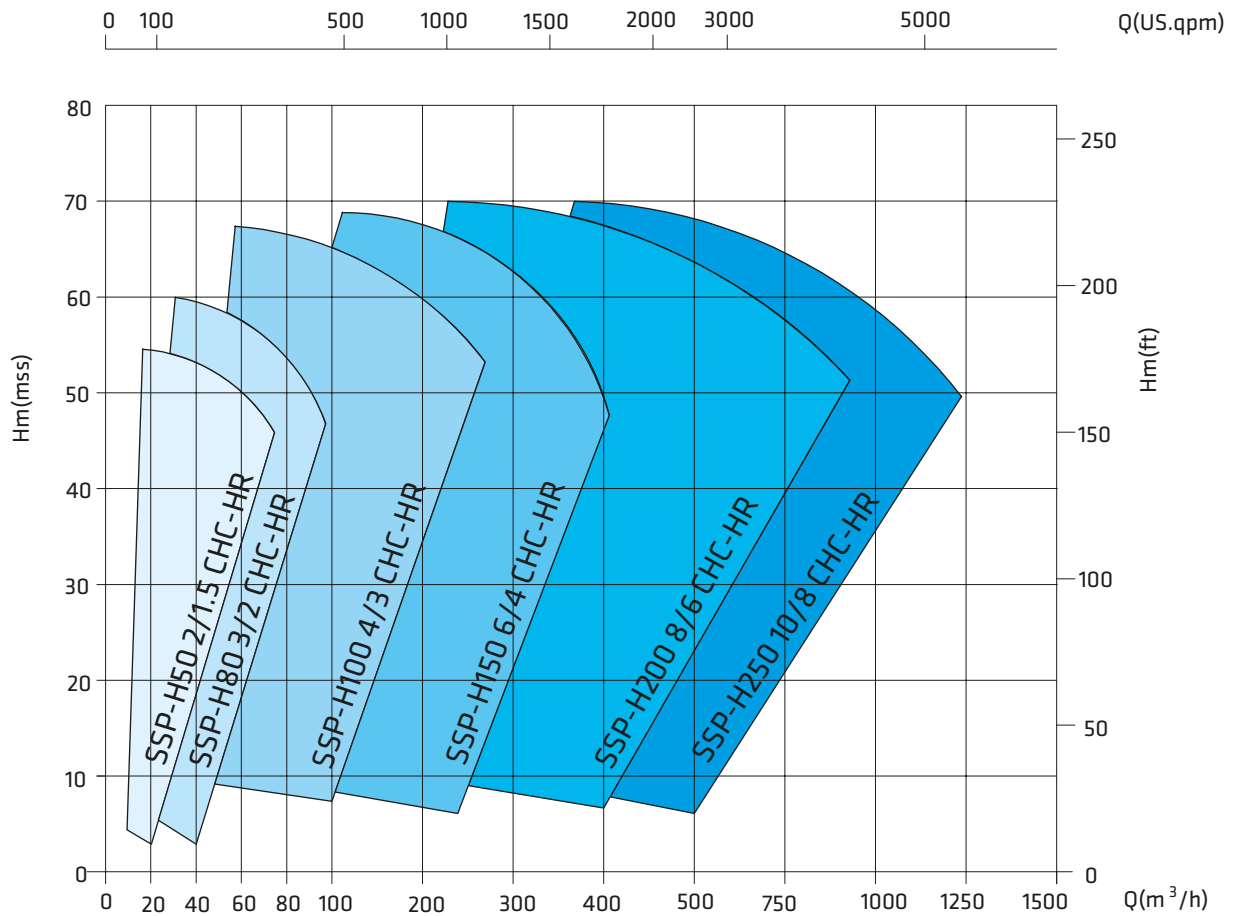

- SSP-H CHC HR pump series are liner pumps.
- Outer volute is ductile iron with split casing.
- Volute liner of SSP-H CHC HR pumps are high chromium steel casting in standard. However, different casting material options can be used according to the chemical properties of the fluid.
- The impeller rubber-coated
- SSP-H CHC HR series pump's impeller can be setting with one-way clearance adjustment system.
- There are frame size options for shaft power and applications
- Except H50 an H80 other pumps have 2 different bearing sizes according to their motor power.
- In standard production, H 50 pump have open impeller and the others pumps have closed impeller.
- Shut-off head is approximately 70 m



HORIZONTAL EXTRA HEAVY DUTY RUBBER LINER SLURRY PUMPS

SSP-H FIELD CHART (CR)

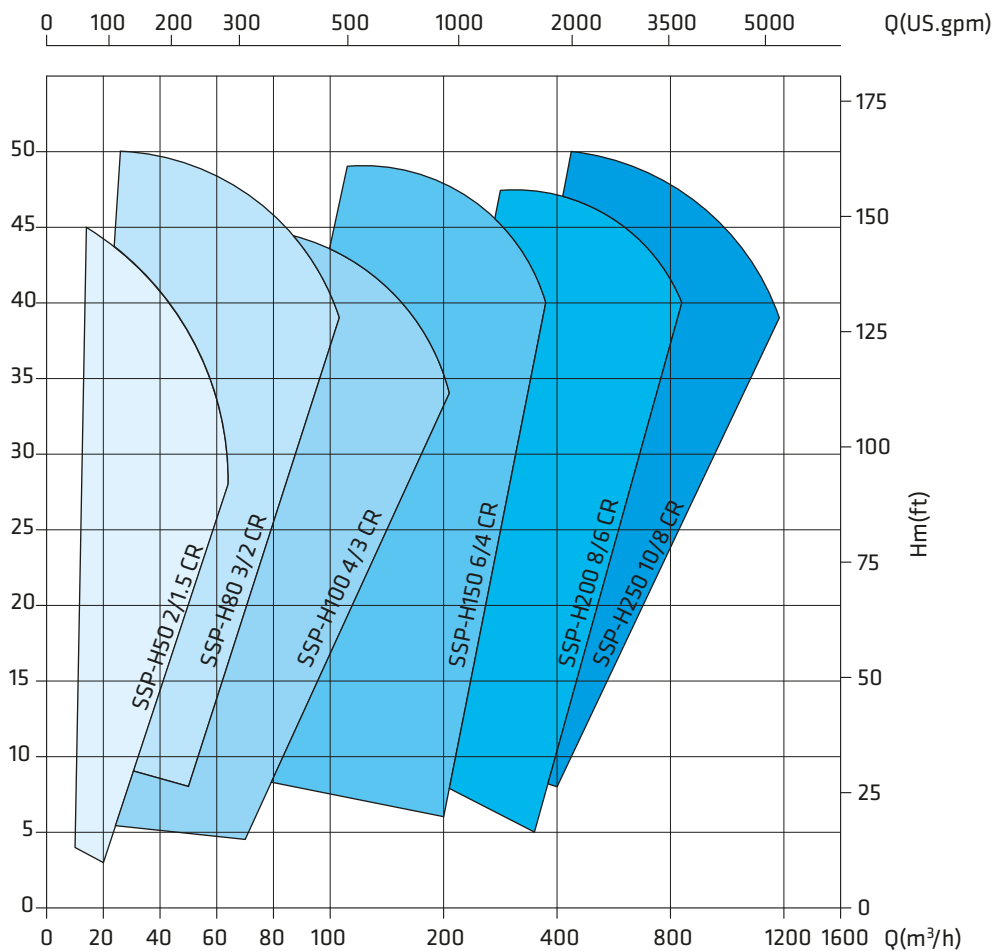

- SSP-H CR pump series are liner pumps.
- Outer volute is ductile iron with split casing. The impeller of the SSP-H CR pumps is rubber-coated and the liner volute is rubber.
- SSP-H CR series pump's impeller can be setting with one-way clearance adjustment system.
- There are frame size options for shaft power and applications
- Except H50 and H80 other pumps have 2 different bearing sizes according to their motor power.
- In standard production, H 50 pump have open impeller and others pumps have closed impeller.
- Shut-off head is approximately 50 m



HORIZONTAL EXTRA HEAVY DUTY RUBBER LINER SLURRY PUMPS

SSP-H FIELD CHART (CR HC)

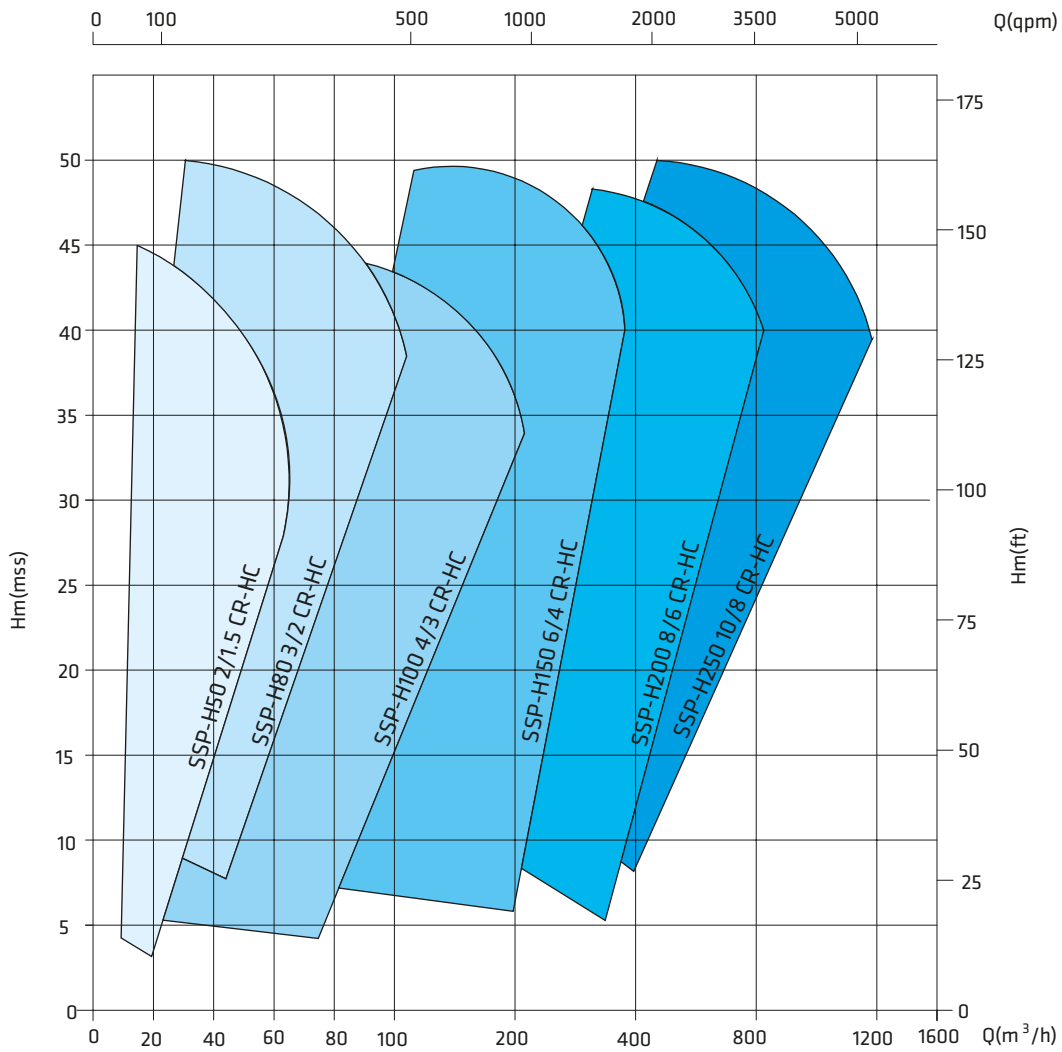

- SSP-H CR HC pump series are liner pumps.
- Outer volute is ductile iron with split casing.
- Volute liner of the SSP-H CR HC pumps is the rubber.
- SSP-H CR HC series pump's impeller can be setting with one-way clearance adjustment system.
- There are frame size options for shaft power and applications
- Except H50 and H80 other pumps have 2 different bearing sizes according to their motor power.
- In standard production, H 50 pump have open impeller and the others pumps have closed impeller.
- Shut-off head is approximately 50 m.



Impeller Types

As standart manufacturing, SSP-H pump series have horizontal, volute casing, single stage and closed impeller. Semi-open vortex and full-recessed vortex impeller types can be applied in different requirements.



Closed Impeller (Standart)

Kapalı çark akışkanlardaki küçük ve orta boyutlu katı parçaların transferi gerçekleştirilmektedir. SSP-H serisinde diğer çark tiplerine göre daha yüksek verimliliğe sahiptir. Transfer edilecek akışkanın aşındırıcı özelliğine göre malzeme seçimi ile yüksek performanslı ve uzun ömürlü çözümler sunar. Büyük basma yüksekliklerinde yüksek verimlerde kullanılmaktadır.

Vortex Impeller

Vortex impellers are used in transfer of fluids containing large solid particles at low head. More life time is offered since large solid particles would have less contact area with the vortex impeller. These impellers are less efficient than the others.

Full-Recessed Vortex Impeller

Full-recessed vortex impellers are applied when large, solid fibrous particles involved in handled fluid. It can pass that solids as large as discharge diameter. Minimum contact area is accomplished between solid particles in fluid and the impeller. These impeller types are preferred for preventing damages to solid particles in fluid. But it's shut-off head and efficiency are less than other type impellers. Applicable only on SSP H HC series pumps.



Semi-open Impeller

Large and medium solid particles are transferred with semi-open impeller type. It offers high efficient and more durable solutions regarding material selection and abrasive properties of the handled fluid. Semi-open impellers prevent greater efficient loss in use of larger particles. It is preferred low and medium heads.

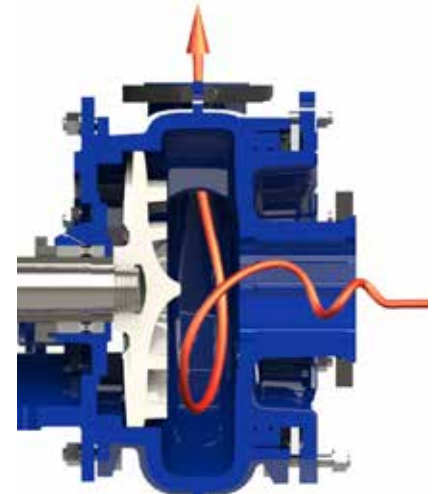

Shaft Sealing

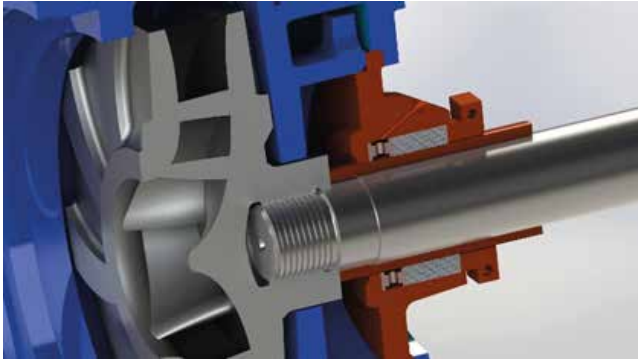

SSP HC, CR, CHC Packing Sealing

- Shaft sleeve and stuffing box sealing can be cooled and lubricated by an external cooling system or the pumping liquid.
- Distance adjustment between wear plate and back vanes of the impeller can set the pressure on sealing.

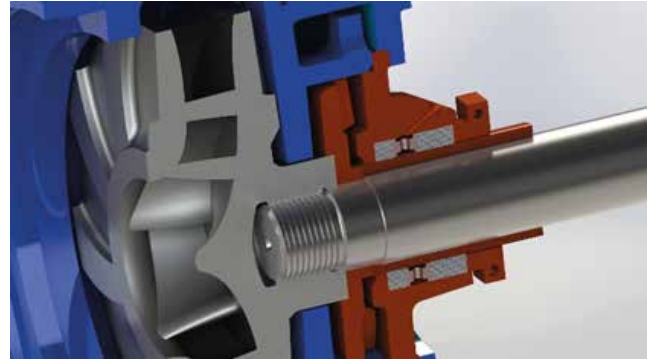

SSP HC, CR, CHC Hydrodynamic and Packing Sealing

- Hydrodynamic and shaft sleeve and stuffing box sealing can be cooled and lubricated by an external cooling system or the pumping liquid.
- Expeller provides hydrodynamic sealing by depressurizing on stuffing box area. It improves lifetime of shaft sleeve and packing sealing.

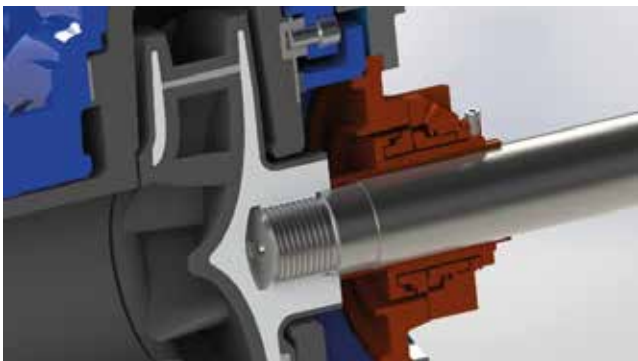

SSP HC, CR, CHC Cartridge Type Single Mechanical Sealing

- Hydraulic film between sealing surface elements is formed by pumping fluid or externally injected liquid which is the way of API 682 approved.
- Distance adjustment between wear plate and back vanes of the impeller can set the pressure on cartridge mechanical sealing.



SSP HC, CR, CHC Cartridge Type Double Mechanical Sealing

- Hydraulic film between sealing surface elements is formed by a pressured barrier liquid externally which is the way of API 682 approved.
- Distance adjustment between wear plate and back vanes of the impeller can set the pressure on cartridge mechanical sealing.

Adjustment Mechanism

General

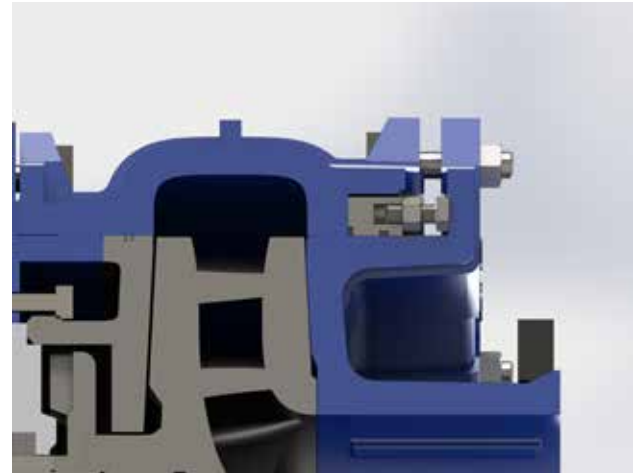
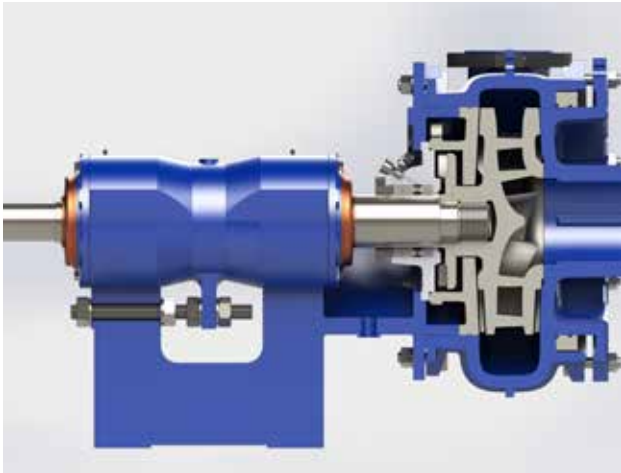

SSP-H pump series have major advantages to transfer fluid that has corrosive and abrasive properties. Even though these properties would have decrease pump performances in time, distance adjustment mechanisms on the SSP-H pump series can optimise the pump performances and improve service time. Only SSP-H HC pump series have two-way clearance adjustment system. SSP-H CHC and CR pump series have one-way clearance adjustment system.

Back-side Clearance

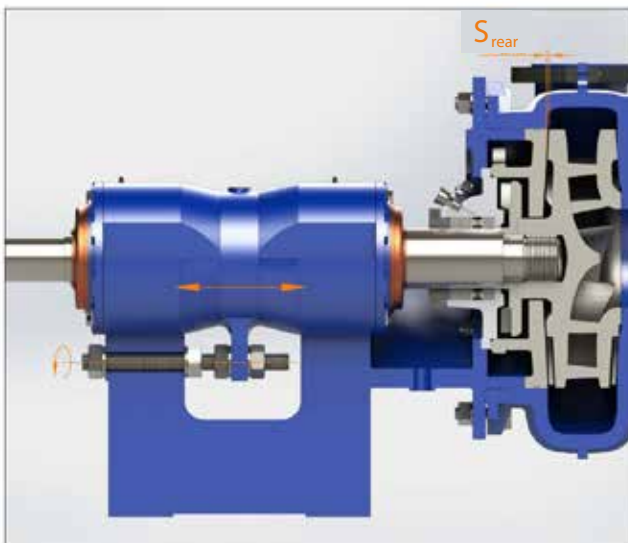

Stud bolts on bearing housing lead the movement of cartridge housing at SSP-H series HC/CR/CHC model pumps. Therefore distance between impeller and wear plate can be controlled. Back-side clearance adjustment keep the pump performance up even wearing happens between the wear plate and the impeller.

Front-side clearance

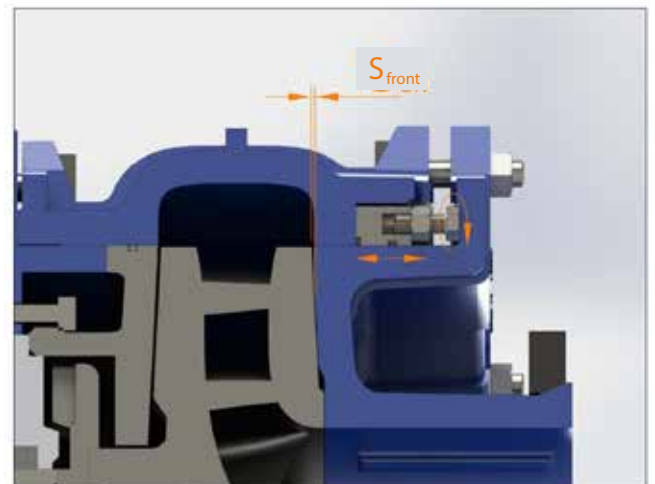

SSP-H series HC model pumps have front gap adjustment. Stop bolts in front of volute casing can set the gap between inlet port and impeller. Therefore negative effects of wearing optimise and service time of the pump improves. Besides that there is no need disassembly of volute casing and time is saved accordingly.

Sliding Base Frame Application



Base Plate Closed



Base Plate Open

SSP-H pump series can be application sliding base frame. The sliding base frame provides maintainability where there is no lift and no enough movement area. using sliding base frame instead of a fixed base has eliminated high risk manual handling and reduced downtime approximetely by %50. This reduction in downtime on the HC pump series are due to only having to unbolt the casing bolts to slide the wet end and motor apart to expose wear parts. Since CHC and CR pump series have split type, therefore these series pumps must be removed discharge flanges bolts and the casing bolts to slide the wet end and motor apart expose wear parts. Trapezoidal thread is used to slide the sliding base frame as standart. Wheeled system and hydraulic system applications can also be made.

Dimensions (SSP-H HC)

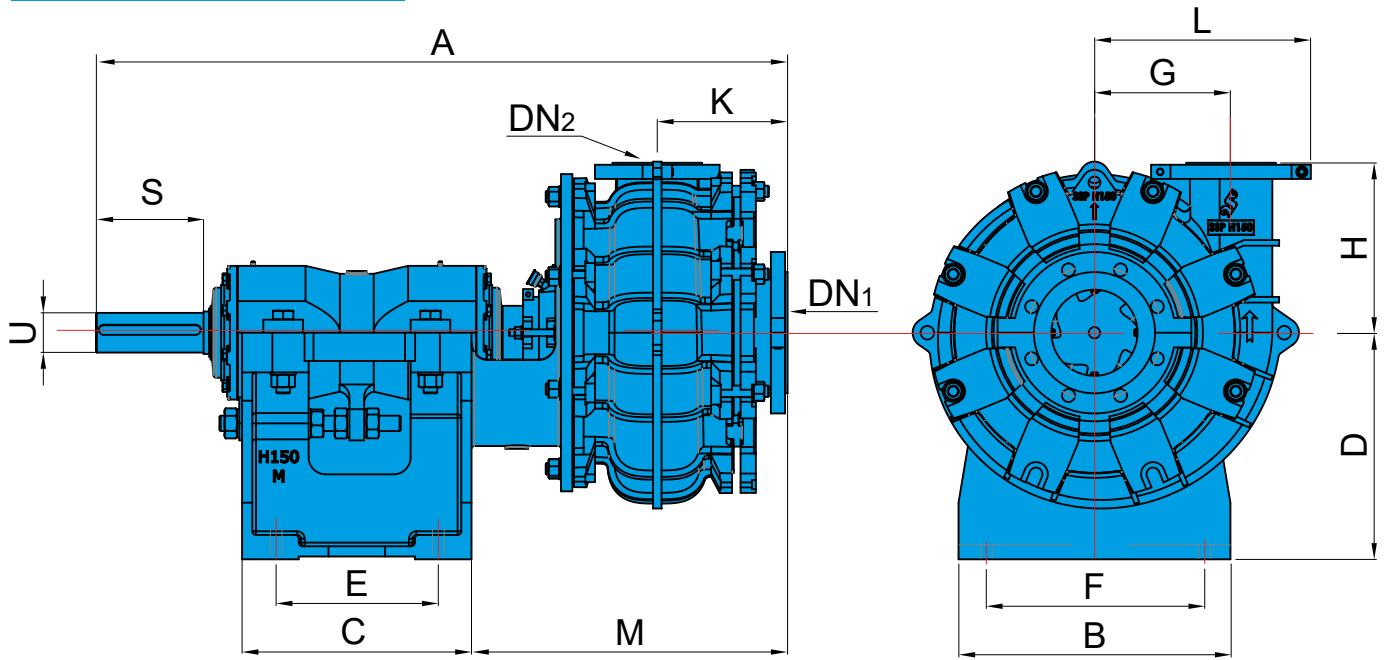

DIMENSIONS (mm)

Pump Type	DIMENSIONS (mm)														Weight (kg)
	A	B	C	D	E	U	Key Size	S	F	G	H	K	L	M	
H40 1.5x1 HC J	610	250	204	175	134	28	8x7	80	200	102	150	110	159	292	79
H50 2x1.5 HC J	624	300	204	190	134	28	8x7	80	250	125	185	116	200	306	120
H80 3x2 HC K	825	360	260	230	180	42	12x8	100	290	140	210	175	223	419	208
H100 4x3 HC K	869	410	260	280	180	42	12x8	100	350	185	265	197	285	464	301
H100 4x3 HC L	1027	410	342	280	240	55	16x10	135	350	185	265	197	285	487	356
H150 6x4 HC L	1078	480	342	400	240	55	16x10	135	410	241	300	230	351	538	567
H150 6x4 HC M	1221	480	405	400	300	70	20x12	190	420	241	300	230	351	558	668
H200 8x6 HC M	1312	650	405	520	300	70	20x12	190	580	320	460	275	462	649	1192
H200 8x6 HC N	1570	650	545	520	385	100	28x16	265	580	320	460	275	462	682	1467
H250 10x8 HC N	1613	780	545	620	385	100	28x16	265	640	383	500	300	553	724	1906
H250 10x8 HC P	1736	780	634	620	474	120	32x18	280	640	383	500	300	553	739	2177
H300 12x10 HC P	1813	920	634	650	474	120	32x18	280	780	445	560	360	642	816	2855

(*) All dimensions (mm)

Pump Type	DN ₁				DN ₂			
	D ₀	D ₁	D ₂	Ød	D ₀	D ₁	D ₂	Ød
H40 1.5x1 HC J	40	110	150	4-Ø18	25	85	115	4-Ø14
H50 2x1.5 HC J	50	125	165	4-Ø18	40	110	150	4-Ø18
H80 3x2 HC K	80	160	200	8-Ø18	50	125	165	4-Ø18
H100 4x3 HC K	100	180	220	8-Ø18	80	160	200	8-Ø18
H100 4x3 HC L	100	180	220	8-Ø18	80	160	200	8-Ø18
H150 6x4 HC L	150	240	285	8-Ø23	100	180	220	8-Ø18
H150 6x4 HC M	150	240	285	8-Ø23	100	180	220	8-Ø18
H200 8x6 HC M	200	295	340	8-Ø23	150	240	285	8-Ø23
H200 8x6 HC N	200	295	340	8-Ø23	150	240	285	8-Ø23
H250 10x8 HC N	250	350	395	12-Ø23	200	295	340	8-Ø23
H250 10x8 HC P	250	350	395	12-Ø23	200	295	340	8-Ø23
H300 12x10 HC P	300	400	445	12-Ø23	250	350	395	12-Ø23

(*) All dimensions (mm)

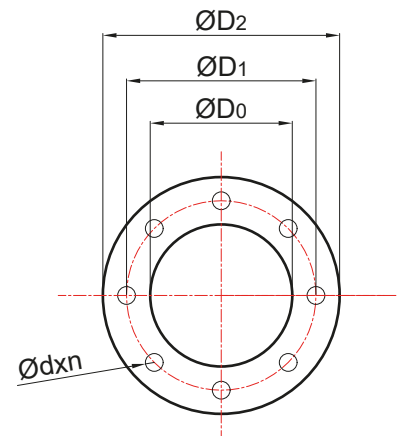

Dimensions (SSP-H CHC/CHC HR)

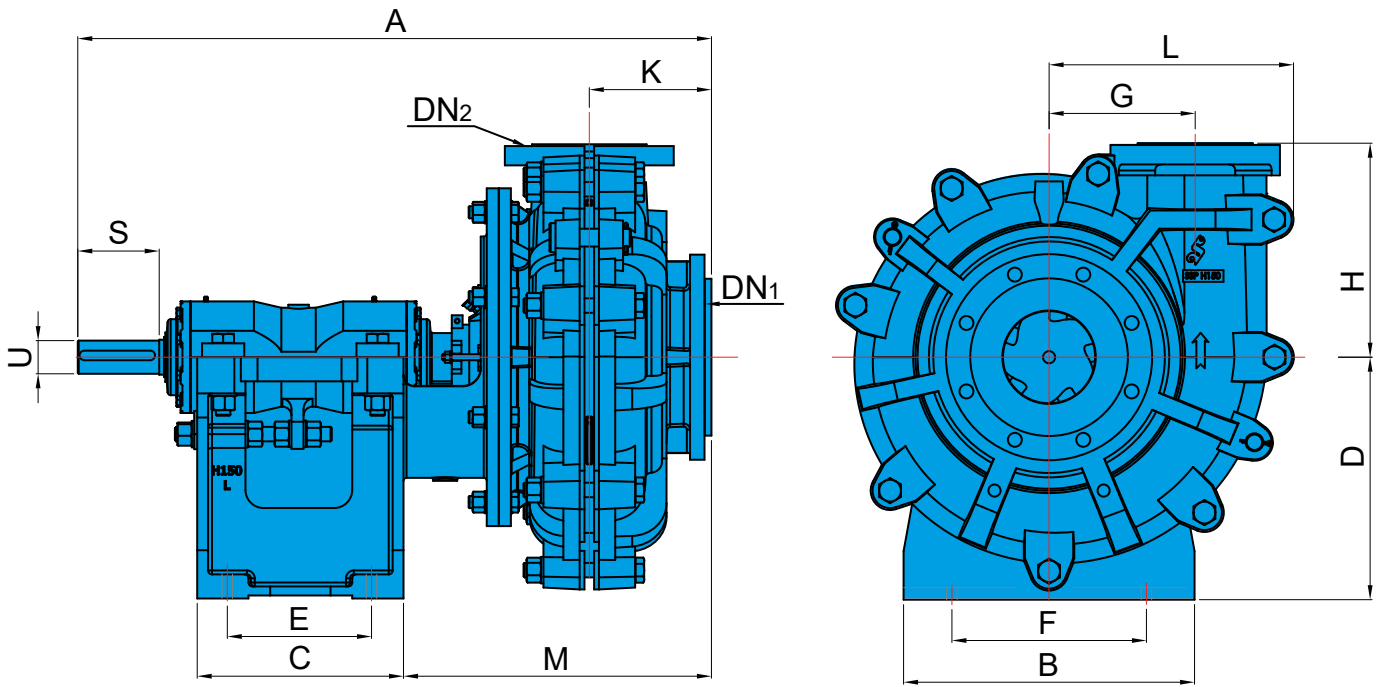

DIMENSIONS (mm)

Pump Type	DIMENSIONS (mm)														Weight (kg)
	A	B	C	D	E	U	Key Size	S	F	G	H	K	L	M	
H50 2x1.5-CR J	627	300	204	190	134	28	8x7	80	250	130	200	114	230	309	108
H50 2x1.5-CHC J	627	300	204	190	134	28	8x7	80	250	130	200	114	230	309	126
H80 3x2-CR K	780	360	260	230	180	42	12x8	100	290	140	240	130	260	375	178
H80 3x2-CHC K	780	360	260	230	180	42	12x8	100	290	140	240	130	260	375	212
H100 4x3-CR K	846	410	260	280	180	42	12X8	100	350	185	302	174	330	441	261
H100 4x3-CHC K	846	410	260	280	180	42	12X8	100	350	185	302	174	330	441	341
H100 4x3-CR L	1005	410	342	280	240	55	16X10	135	350	185	302	174	330	465	316
H100 4x3-CHC L	1005	410	342	280	240	55	16X10	135	350	185	302	174	330	465	396
H150 6x4-CR L	1050	480	342	400	240	55	16X10	135	410	241	353	203	403	510	512
H150 6x4-CHC L	1050	480	342	400	240	55	16X10	135	410	241	353	203	403	510	644
H150 6x4-CR M	1194	480	405	400	300	70	20X12	190	410	241	353	203	403	530	613
H150 6x4-CHC M	1194	480	405	400	300	70	20X12	190	410	241	353	203	403	530	745
H200 8x6-CR M	1282	650	405	520	300	70	20X12	190	580	320	510	245	528	619	1168
H200 8x6-CHC M	1282	650	405	520	300	70	20X12	190	580	320	510	245	528	619	1435
H200 8x6-CR N	1540	650	545	520	385	100	28X16	265	580	320	510	245	528	652	1443
H200 8x6-CHC N	1540	650	545	520	385	100	28X16	265	580	320	510	245	528	652	1710
H250 10x8-CR N	1588	780	545	620	385	100	28X16	265	640	383	550	275	638	699	1808
H250 10x8-CHC N	1588	780	545	620	385	100	28X16	265	640	383	550	275	638	699	2205
H250 10x8-CR P	1711	780	634	620	474	120	32X18	280	640	383	550	275	638	714	2079
H250 10x8-CHC P	1711	780	634	620	474	120	32X18	280	640	383	550	275	638	714	2476
H300 12x10-CHC P	1813	920	634	650	474	120	32x18	280	780	444	610	360	665	816	3196

(* All dimensions (mm))

Pump Type	DN ₁				DN ₂			
	D ₀	D ₁	D ₂	Ød	D ₀	D ₁	D ₂	Ød
	H50 2x1.5 CHC J	50	145	185	4-Ø18	40	125	165
H80 3x2 CHC K	80	180	220	8-Ø18	50	145	185	4-Ø18
H100 4x3 CHC K	100	210	250	8-Ø18	80	180	220	8-Ø18
H100 4x3 CHC L	100	210	250	8-Ø18	80	180	220	8-Ø18
H150 6x4 CHC L	150	295	340	8-Ø23	100	210	250	8-Ø18
H150 6x4 CHC M	150	295	340	8-Ø23	100	210	250	8-Ø18
H200 8x6 CHC M	200	350	395	12-Ø23	150	295	340	8-Ø23
H200 8x6 CHC N	200	350	395	12-Ø23	150	295	340	8-Ø23
H250 10x8 CHC N	250	400	445	12-Ø23	200	350	395	12-Ø23
H250 10x8 CHC P	250	400	445	12-Ø23	200	350	395	12-Ø23
H300 12x10 CHC P	300	460	505	16-Ø23	250	400	445	12-Ø23

CHC and CHC HR Flange dimensions are the same.

(* All dimensions (mm))

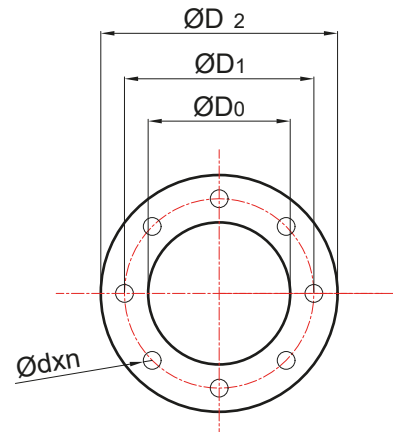

Dimensions (SSP-H CR/CR HC)

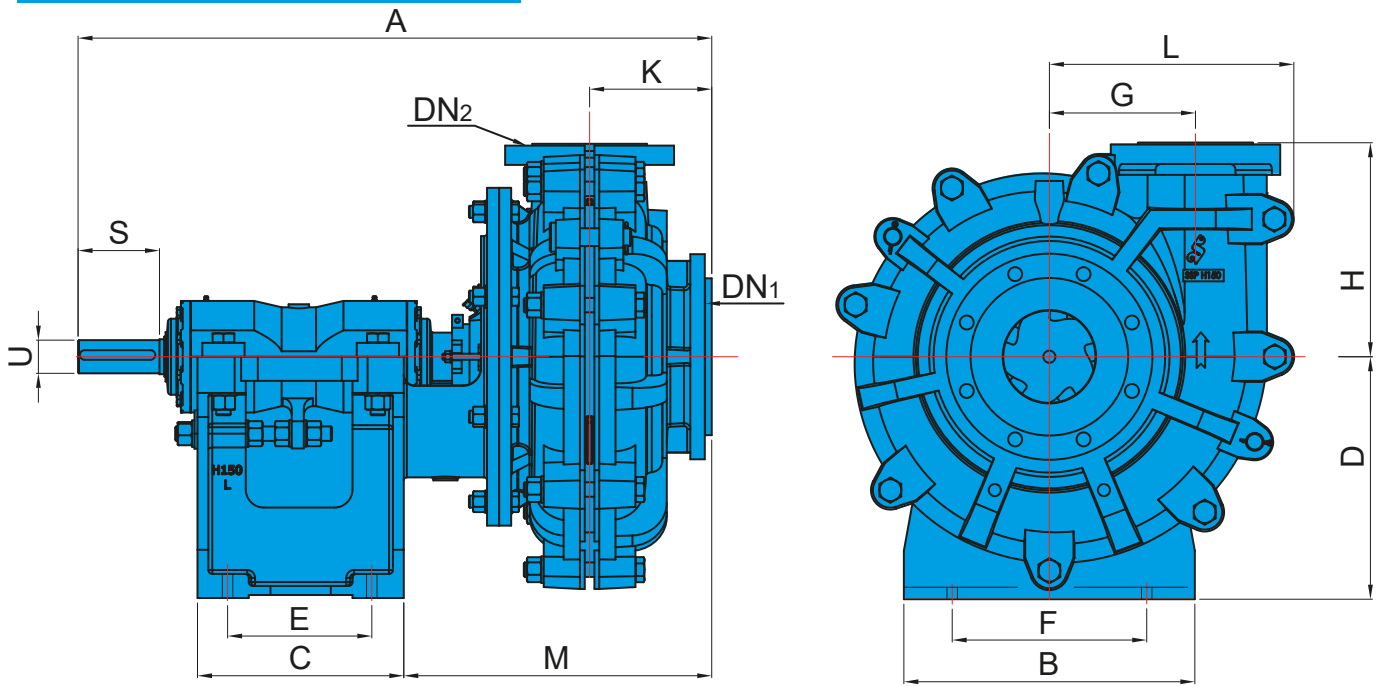

DIMENSIONS (mm)

Pump Type	A	B	C	D	E	U	Key Size	S	F	G	H	K	L	M	Weight (kg)
H50 2x1.5-CR J	627	300	204	190	134	28	8x7	80	250	130	200	114	230	309	108
H50 2x1.5-CR HC J	627	300	204	190	134	28	8x7	80	250	130	200	114	230	309	111
H80 3x2-CR K	780	360	260	230	180	42	12x8	100	290	140	240	130	260	375	178
H80 3x2-CR HC K	780	360	260	230	180	42	12x8	100	290	140	240	130	260	375	187
H100 4x3-CR K	846	410	260	280	180	42	12x8	100	350	185	302	174	330	441	261
H100 4x3-CR HC K	846	410	260	280	180	42	12x8	100	350	185	302	174	330	441	275
H100 4x3-CR L	1005	410	342	280	240	55	16x10	135	350	185	302	174	330	465	316
H100 4x3-CR HC L	1005	410	342	280	240	55	16x10	135	350	185	302	174	330	465	330
H150 6x4-CR L	1050	480	342	400	240	55	16x10	135	410	241	353	203	403	510	512
H150 6x4-CR HC L	1050	480	342	400	240	55	16x10	135	410	241	353	203	403	510	544
H150 6x4-CR M	1194	480	405	400	300	70	20x12	190	410	241	353	203	403	530	613
H150 6x4-CR HC M	1194	480	405	400	300	70	20x12	190	410	241	353	203	403	530	645
H200 8x6-CR M	1282	650	405	520	300	70	20x12	190	580	320	510	245	528	619	1168
H200 8x6-CR HC M	1282	650	405	520	300	70	20x12	190	580	320	510	245	528	619	1230
H200 8x6-CR N	1540	650	545	520	385	100	28x16	265	580	320	510	245	528	652	1443
H200 8x6-CR HC N	1540	650	545	520	385	100	28x16	265	580	320	510	245	528	652	1505
H250 10x8-CR N	1588	780	545	620	385	100	28x16	265	640	383	550	275	638	699	1808
H250 10x8-CR HC N	1588	780	545	620	385	100	28x16	265	640	383	550	275	638	699	1909
H250 10x8-CR P	1711	780	634	620	474	120	32x18	280	640	383	550	275	638	714	2079
H250 10x8-CR HC P	1711	780	634	620	474	120	32x18	280	640	383	550	275	638	714	2180

(*) All dimensions (mm)

Pump Type	DN ₁				DN ₂			
	D ₀	D ₁	D ₂	Ød	D ₀	D ₁	D ₂	Ød
H50 2x1.5 CHC J	50	145	185	4-Ø18	40	125	165	4-Ø18
H80 3x2 CHC K	80	180	220	8-Ø18	50	145	185	4-Ø18
H100 4x3 CHC K	100	210	250	8-Ø18	80	180	220	8-Ø18
H100 4x3 CHC L	100	210	250	8-Ø18	80	180	220	8-Ø18
H150 6x4 CHC L	150	295	340	8-Ø23	100	210	250	8-Ø18
H150 6x4 CHC M	150	295	340	8-Ø23	100	210	250	8-Ø18
H200 8x6 CHC M	200	350	395	12-Ø23	150	295	340	8-Ø23
H200 8x6 CHC N	200	350	395	12-Ø23	150	295	340	8-Ø23
H250 10x8 CHC N	250	400	445	12-Ø23	200	350	395	12-Ø23
H250 10x8 CHC P	250	400	445	12-Ø23	200	350	395	12-Ø23

CR and CR HC Flange dimensions are the same.

(*) All dimensions (mm)

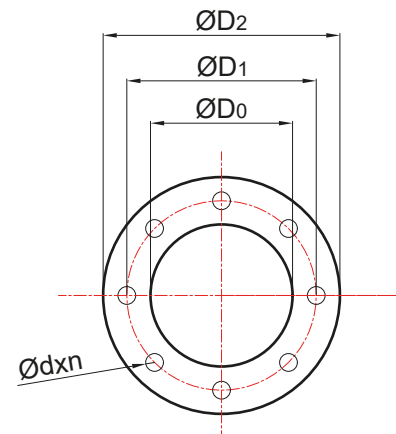

Installation Types

TP01

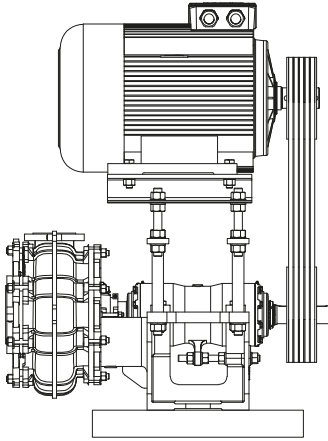

TP02

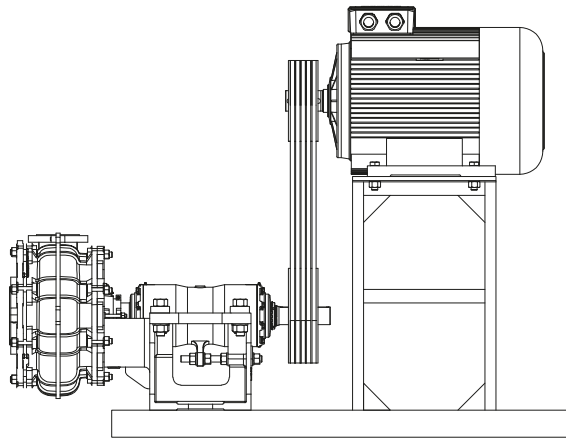

TP03

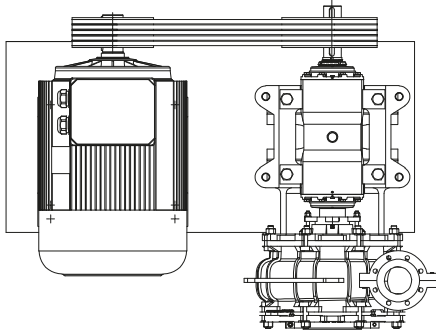

TP04

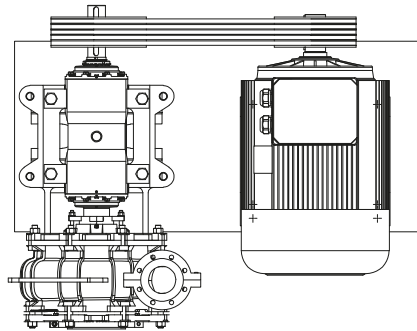

TP05

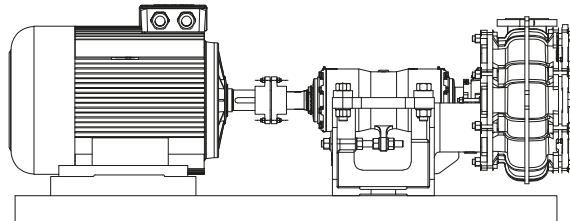

TP06

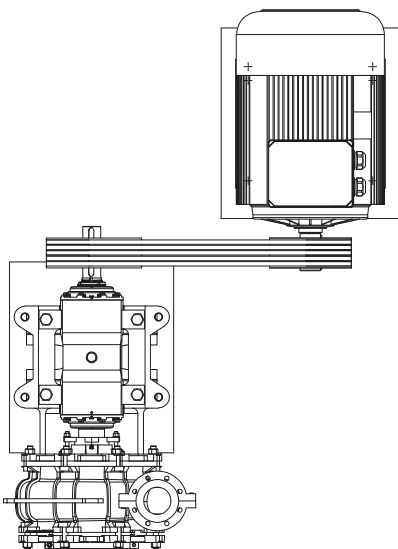

TP07

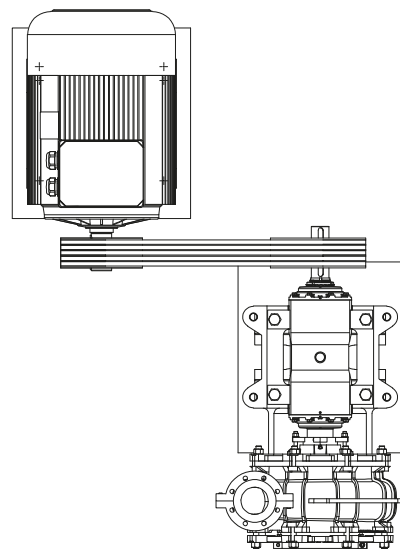

Material Options (HC)

PART LIST	0.6025	0.7040	0.7043	0.7050	1.0619	1.0037	1.3505	1.4317	1.4525	1.4308	1.4412	1.4527	1.4468	1.4517	1.4469	5.5610	2.1050.01	2.0975.01	2.1096.01	2.0975	1.4021	1.4021(QT)	1.4301	1.4404	1.4460	1.4462	1.0503
Volute Casing	<input type="radio"/>	<input type="radio"/>	<input type="radio"/>	<input type="radio"/>	<input type="radio"/>			<input type="radio"/>	<input type="radio"/>	<input type="radio"/>	<input type="radio"/>	<input type="radio"/>	<input type="radio"/>	<input type="radio"/>	<input type="radio"/>	<input checked="" type="radio"/>	<input type="radio"/>	<input type="radio"/>	<input type="radio"/>	<input type="radio"/>							
Impeller	<input type="radio"/>	<input type="radio"/>	<input type="radio"/>	<input type="radio"/>	<input type="radio"/>			<input type="radio"/>	<input type="radio"/>	<input type="radio"/>	<input type="radio"/>	<input type="radio"/>	<input type="radio"/>	<input type="radio"/>	<input type="radio"/>	<input checked="" type="radio"/>	<input type="radio"/>	<input type="radio"/>	<input type="radio"/>	<input type="radio"/>							
Back Wear Plate	<input type="radio"/>	<input type="radio"/>	<input type="radio"/>	<input type="radio"/>	<input type="radio"/>			<input type="radio"/>	<input type="radio"/>	<input type="radio"/>	<input type="radio"/>	<input type="radio"/>	<input type="radio"/>	<input type="radio"/>	<input type="radio"/>	<input checked="" type="radio"/>	<input type="radio"/>	<input type="radio"/>	<input type="radio"/>	<input type="radio"/>							
Expeller Ring	<input type="radio"/>	<input type="radio"/>	<input type="radio"/>	<input type="radio"/>	<input type="radio"/>			<input type="radio"/>	<input type="radio"/>	<input type="radio"/>	<input type="radio"/>	<input type="radio"/>	<input type="radio"/>	<input type="radio"/>	<input type="radio"/>	<input checked="" type="radio"/>	<input type="radio"/>	<input type="radio"/>	<input type="radio"/>	<input type="radio"/>							
Stuffing Box	<input type="radio"/>	<input type="radio"/>	<input type="radio"/>	<input type="radio"/>	<input type="radio"/>			<input type="radio"/>	<input type="radio"/>	<input type="radio"/>	<input type="radio"/>	<input type="radio"/>	<input type="radio"/>	<input type="radio"/>	<input type="radio"/>	<input checked="" type="radio"/>	<input type="radio"/>	<input type="radio"/>	<input type="radio"/>	<input type="radio"/>							
Expeller	<input type="radio"/>	<input type="radio"/>	<input type="radio"/>	<input type="radio"/>	<input type="radio"/>			<input type="radio"/>	<input type="radio"/>	<input type="radio"/>	<input type="radio"/>	<input type="radio"/>	<input type="radio"/>	<input type="radio"/>	<input type="radio"/>	<input checked="" type="radio"/>	<input type="radio"/>	<input type="radio"/>	<input type="radio"/>	<input type="radio"/>							
Bearing Housing	<input checked="" type="radio"/>	<input type="radio"/>	<input type="radio"/>	<input type="radio"/>																							
Cartridge Housing	<input checked="" type="radio"/>	<input type="radio"/>	<input type="radio"/>	<input type="radio"/>																							
Shaft																					<input checked="" type="radio"/>	<input type="radio"/>	<input type="radio"/>	<input type="radio"/>	<input type="radio"/>	<input type="radio"/>	<input type="radio"/>
Shaft Sleeve							<input checked="" type="radio"/>														<input type="radio"/>	<input type="radio"/>	<input type="radio"/>	<input type="radio"/>	<input type="radio"/>	<input type="radio"/>	<input type="radio"/>
Pump Flanges	<input type="radio"/>	<input type="radio"/>	<input type="radio"/>	<input type="radio"/>		<input checked="" type="radio"/>										<input type="radio"/>											
Bolt, Nut and Washer																							<input checked="" type="radio"/>	<input type="radio"/>			

Standard manufacturing
 Optional

PART LIST	EPDM	VITON	NR
O-Ring	<input type="radio"/>	<input type="radio"/>	<input checked="" type="radio"/>
Gasket	<input type="radio"/>	<input type="radio"/>	<input checked="" type="radio"/>

Material Options (CHC)

PART LIST	0.6025	0.7040	0.7043	0.7050	1.0619	1.0037	1.3505	1.4317	1.4525	1.4308	1.4412	1.4527	1.4468	1.4517	1.4469	5.5610	2.1050.01	2.0975.01	2.1096.01	2.0975	1.4021	1.4021(QT)	1.4301	1.4404	1.4460	1.4462	1.0503
Volute Casing	<input type="radio"/>	<input checked="" type="radio"/>	<input type="radio"/>	<input type="radio"/>	<input type="radio"/>			<input type="radio"/>	<input type="radio"/>	<input type="radio"/>	<input type="radio"/>	<input type="radio"/>	<input type="radio"/>	<input type="radio"/>	<input type="radio"/>	<input type="radio"/>	<input type="radio"/>	<input type="radio"/>	<input type="radio"/>	<input type="radio"/>							
Inner Volute Lining	<input type="radio"/>	<input type="radio"/>	<input type="radio"/>	<input type="radio"/>	<input type="radio"/>			<input type="radio"/>	<input type="radio"/>	<input type="radio"/>	<input type="radio"/>	<input type="radio"/>	<input type="radio"/>	<input type="radio"/>	<input type="radio"/>	<input checked="" type="radio"/>	<input type="radio"/>	<input type="radio"/>	<input type="radio"/>	<input type="radio"/>							
Impeller	<input type="radio"/>	<input type="radio"/>	<input type="radio"/>	<input type="radio"/>	<input type="radio"/>			<input type="radio"/>	<input type="radio"/>	<input type="radio"/>	<input type="radio"/>	<input type="radio"/>	<input type="radio"/>	<input type="radio"/>	<input type="radio"/>	<input checked="" type="radio"/>	<input type="radio"/>	<input type="radio"/>	<input type="radio"/>	<input type="radio"/>							
Back Wear Plate	<input type="radio"/>	<input type="radio"/>	<input type="radio"/>	<input type="radio"/>	<input type="radio"/>			<input type="radio"/>	<input type="radio"/>	<input type="radio"/>	<input type="radio"/>	<input type="radio"/>	<input type="radio"/>	<input type="radio"/>	<input type="radio"/>	<input checked="" type="radio"/>	<input type="radio"/>	<input type="radio"/>	<input type="radio"/>	<input type="radio"/>							
Expeller Ring	<input type="radio"/>	<input type="radio"/>	<input type="radio"/>	<input type="radio"/>	<input type="radio"/>			<input type="radio"/>	<input type="radio"/>	<input type="radio"/>	<input type="radio"/>	<input type="radio"/>	<input type="radio"/>	<input type="radio"/>	<input type="radio"/>	<input checked="" type="radio"/>	<input type="radio"/>	<input type="radio"/>	<input type="radio"/>	<input type="radio"/>							
Stuffing Box	<input type="radio"/>	<input type="radio"/>	<input type="radio"/>	<input type="radio"/>	<input type="radio"/>			<input type="radio"/>	<input type="radio"/>	<input type="radio"/>	<input type="radio"/>	<input type="radio"/>	<input type="radio"/>	<input type="radio"/>	<input type="radio"/>	<input checked="" type="radio"/>	<input type="radio"/>	<input type="radio"/>	<input type="radio"/>	<input type="radio"/>							
Expeller	<input type="radio"/>	<input type="radio"/>	<input type="radio"/>	<input type="radio"/>	<input type="radio"/>			<input type="radio"/>	<input type="radio"/>	<input type="radio"/>	<input type="radio"/>	<input type="radio"/>	<input type="radio"/>	<input type="radio"/>	<input type="radio"/>	<input checked="" type="radio"/>	<input type="radio"/>	<input type="radio"/>	<input type="radio"/>	<input type="radio"/>							
Bearing Housing	<input checked="" type="radio"/>	<input type="radio"/>	<input type="radio"/>	<input type="radio"/>																							
Cartridge Housing	<input checked="" type="radio"/>	<input type="radio"/>	<input type="radio"/>	<input type="radio"/>																							
Shaft																					<input checked="" type="radio"/>	<input type="radio"/>	<input type="radio"/>	<input type="radio"/>	<input type="radio"/>	<input type="radio"/>	<input type="radio"/>
Shaft Sleeve							<input checked="" type="radio"/>														<input type="radio"/>	<input type="radio"/>	<input type="radio"/>	<input type="radio"/>	<input type="radio"/>	<input type="radio"/>	<input type="radio"/>
Bolt, Nut and Washer																							<input checked="" type="radio"/>	<input type="radio"/>			

Standard manufacturing
 Optional

PART LIST	EPDM	VITON	NR
O-Ring	<input type="radio"/>	<input type="radio"/>	<input checked="" type="radio"/>
Gasket	<input type="radio"/>	<input type="radio"/>	<input checked="" type="radio"/>

Material Options (CHC-HR)

PART LIST	0.6025	0.7040	0.7043	0.7050	1.0619	1.0037	1.3505	1.4317	1.4525	1.4308	1.4412	1.4527	1.4468	1.4517	1.4469	5.5610	2.1050.01	2.0975.01	2.1096.01	2.0975	1.4021	1.4021(QT)	1.4301	1.4404	1.4460	1.4462	1.0503	
Volute Casing	○	●	○	○	○			○	○	○	○	○	○	○	○	○	○	○	○	○	○							
Inner Volute Lining	○	○	○	○	○			○	○	○	○	○	○	○	○	○	○	○	○	○	○							
Impeller	○	●	○	○	○			○	○	○	○	○	○	○	○	○	○	○	○	○	○							
Back Wear Plate	○	○	○	○	○			○	○	○	○	○	○	○	○	○	○	○	○	○	○							
Expeller Ring	○	○	○	○	○			○	○	○	○	○	○	○	○	○	○	○	○	○	○							
Stuffing Box	○	○	○	○	○			○	○	○	○	○	○	○	○	○	○	○	○	○	○							
Expeller	○	○	○	○	○			○	○	○	○	○	○	○	○	○	○	○	○	○	○							
Bearing Housing	●	○	○	○																								
Cartridge Housing	●	○	○	○																								
Shaft																					●	○	○	○	○	○	○	
Shaft Sleeve							●														○	○	○	○	○	○	○	
Bolt, Nut and Washer																							●	○				

PART LIST	NR	CR	IIR	NBR	PU	UR	CSM	FKM	CIIR	EPDM
Impeller (Coating)	●	○	○	○	○	○	○	○	○	○
O-Ring	●							○		○
Gasket	●							○		○

● Standard manufacturing
○ Optional

Material Options (CR)

PART LIST	0.6025	0.7040	0.7043	0.7050	1.0619	1.0037	1.3505	1.4317	1.4525	1.4308	1.4412	1.4527	1.4468	1.4517	1.4469	5.5610	2.1050.01	2.0975.01	2.1096.01	2.0975	1.4021	1.4021(QT)	1.4301	1.4404	1.4460	1.4462	1.0503	
Volute Casing	○	●	○	○	○			○	○	○	○	○	○	○	○	○	○	○	○	○	○							
Impeller (Cast)	○	●	○	○	○			○	○	○	○	○	○	○	○	○	○	○	○	○	○							
Expeller Ring	○	○	○	○	○			○	○	○	○	○	○	○	○	○	○	○	○	○	○							
Stuffing Box	○	○	○	○	○			○	○	○	○	○	○	○	○	○	○	○	○	○	○							
Expeller	○	○	○	○	○			○	○	○	○	○	○	○	○	○	○	○	○	○	○							
Bearing Housing	●	○	○	○																								
Cartridge Housing	●	○	○	○																								
Shaft																						●	○	○	○	○	○	
Shaft Sleeve							●														●	○	○	○	○	○	○	
Bolt, Nut and Washer																							●	○				

PART LIST	NR	CR	IIR	NBR	PU	UR	CSM	FKM	CIIR	EPDM
Inner Volute Lining	●	○	○	○	○	○	○	○	○	○
Impeller (Coating)	●	○	○	○	○	○	○	○	○	○
O-Ring	●							○		○
Gasket	●							○		○

● Standard manufacturing
○ Optional

Material Options (CR-HC)

PART LIST	0.6025	0.7040	0.7043	0.7050	1.0619	1.0037	1.3505	1.4317	1.4525	1.4308	1.4412	1.4527	1.4468	1.4517	1.4469	5.5610	2.1050.01	2.0975.01	2.1096.01	2.0975	1.4021	1.4021(QT)	1.4301	1.4404	1.4460	1.4462	1.0503	
Volute Casing	○	●	○	○	○			○	○	○	○	○	○	○	○	○	○	○	○	○								
Impeller (Cast)	○	○	○	○	○			○	○	○	○	○	○	○	○	●	○	○	○	○								
Expeller Ring	○	○	○	○	○			○	○	○	○	○	○	○	○	●	○	○	○	○								
Stuffing Box	○	○	○	○	○			○	○	○	○	○	○	○	○	●	○	○	○	○								
Expeller	○	○	○	○	○			○	○	○	○	○	○	○	○	●	○	○	○	○								
Bearing Housing	●	○	○	○																								
Cartridge Housing	●	○	○	○																								
Shaft																					●	○	○	○	○	○	○	
Shaft Sleeve							●														○	○	○	○	○	○	○	
Bolt, Nut and Washer																							●	○				

PART LIST	NR	CR	IIR	NBR	PU	UR	CSM	FKM	CIIR	EPDM
Inner Volute Lining	●	○	○	○	○	○	○	○	○	○
O-Ring	●							○		○
Gasket	●							○		○

● Standard manufacturing
○ Optional

Material Equivalents

Description	DIN 17007	EN-DIN	AISI / SAE / ASTM
Cast Iron	0.6025	EN-GJL-250 (GG 25)	A48 Class 40B
Nodular Cast Iron	0.7040	EN-GJS-400-15 (GGG 40)	A536 60-40-18
Nodular Cast Iron	0.7043	EN-GJS-400-18-LT (GGG 40.3)	A536 60-40-18
Nodular Cast Iron	0.7050	EN-GJS-500-7 (GGG 50)	A536 88-55-06
Cast Steel	1.0619	GP240GHGS-C25	A216 WCB
Steel	1.0037	St 37-2	A238Gr.C
Bearing Steel	1.3505	100Cr6	52100
Martenzitic Stainless Cast Steel	1.4317	G-X 4 CrNi 13 4	A743 CA-6NM
Martenzitic Stainless Cast Steel	1.4525	G-X 5 CrNiCu 16 4	A747 CB7Cu-2
Chrome Nickel Cast Steel (Heat Treated)	1.4308	G-X 6 CrNi 19 10	A743 CF-8
Austenitic Cast Steel (Heat Treated)	1.4412	C-X 5 CrNiMo 19 11 3	A743 CG-3M
Austenitic Cast Steel (Heat Treated)	1.4527	C-X 4 NiCrCuMo 30 20 4	A743 CN-7M
Duplex Steel (Austenitic-Ferritic, Heat Treated)	1.4468	G-X 2 CrNiMoN 25 6 3	A890 3A
Duplex Steel (Austenitic-Ferritic, Heat Treated)	1.4517	G-X 2 CrNiMoN 25 6 3 3	A890 1B
Duplex Steel (Austenitic-Ferritic, Heat Treated)	1.4469	G-X 2 CrNiMo 26 7 4	A890 5A
Wear Resistant Casts	5.5610	EN-GJN-HV600 (XCr23)	A532 Class III Type A
Cast Bronze (Tin Alloy)	2.1050.01	CuSn10	B427 C90700
Cast Bronze (Nickel Alloy)	2.0975.01	CuAl 10Ni	B148 C95500
Cast Bronze (Leaded)	2.1096.01	CuSn5ZnPb	B584 C83600
Cast Aluminium Bronze	2.0975	CuAl10 Fe5Ni5	B505 C95800
Carbon Steel	1.0503	C45	AISI 1045
Chrome Steel	1.4021	X20Cr13	A276 Type 420
Chrome Steel (Heat Treated)	1.4021(QT)	X20Cr13	A276 Type 420+QT
Chrome Nickel Steel	1.4301	X5CrNi18-10	A276 Type 304
Chrome Nickel Steel (Low Carbon)	1.4404	X2CrNiMo17-12-2	A276 Type 316
Duplex (Austenitic-Ferritic) Steel	1.4460	X3CrNiMoN27-5-2	AISI 329
Duplex (Austenitic-Ferritic) Steel	1.4462	X2CrNiMoN22-5-3	UNS S32205

RUBBER MATERIALS

Natural Rubber	NR	Urethane	UR
Neoprene	CR	Hypalon	CSM
Synthetic Rubber (Butyl)	IIR	Viton	FKM
Nitril Rubber	NBR	Chlorobutyl	CIIR
Polyurethane	PU	Ethylene Propylene Diene	EPDM