

MULTISTAGE CENTRIFUGAL PUMPS



Handled Liquids

Clean or slightly contaminated low viscosity liquids without solid & fibrous particles.

Technical Data

Discharge Flange _____ DN 32.....DN 250 mm

Capacity _____ up to 1000 m³/h

Head _____ up to 550 m

Speed _____ up to 2900 rpm

Operating Temperature _____ 10°C up to +140 °C*

Casing Pressure (Pmax) _____ 30 bar (63 bar)*

(Pmax: Suction Pressure + Shut off Head)

(*) The Material of pumps differ according to the type of pumped liquid, operating temperature and pressure. Contact for detailed information.

Design Features

- Horizontal ring section, multistage, centrifugal pumps with closed impeller and diffuser.

- 10 Models from DN 32 up to 250 discharge flange diameter.

- Suction nozzle flanges conform to EN 1092 - 2 / PN 16 and discharge nozzle flanges conform to EN 1092 - 2 / PN 40 (PN 63) (For steel or stainless steel casing pumps, flanges conform to related pressure class ratings defined in EN 1092 - 1)

Pump Designation

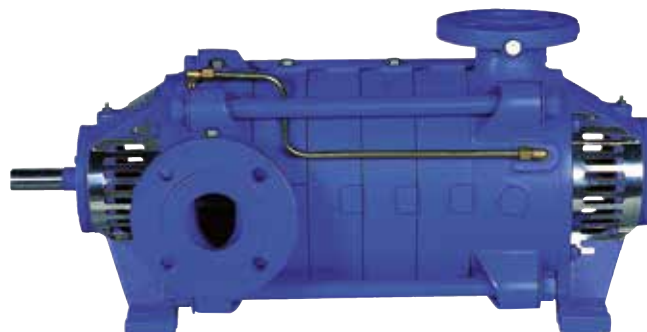
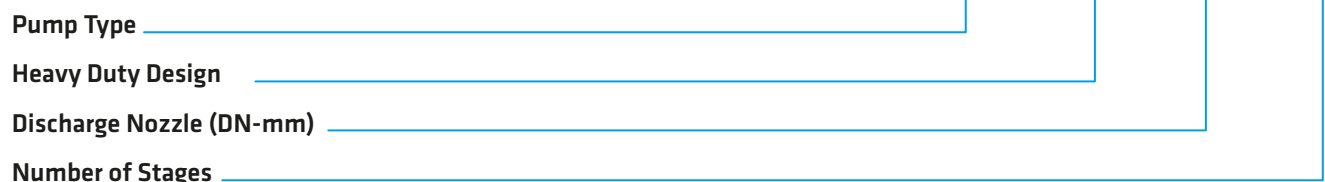

- In standard production, suction flange is placed on the right side and close to the coupling while discharge flange is at the other end and radially upwards (R 3/0). If other flange position is required, it should be indicated in the order.

- All impellers are balanced dynamically or statically according to ISO 1940 class 6.3.

- Axial thrust is balanced by impeller balancing holes system.

- Direction of rotation is clockwise viewed from drive end.

- Bearings of SKM type pumps are always grease lubricated.

Shaft Sealing

- In standard production soft packing application is applied up to 110 °C. Between 110 °C and 140 °C soft packing may also applied together with the stuffing box cooling.

- Pumps with mechanical seal can also be manufactured upon request.

SKM - K 100 / 6

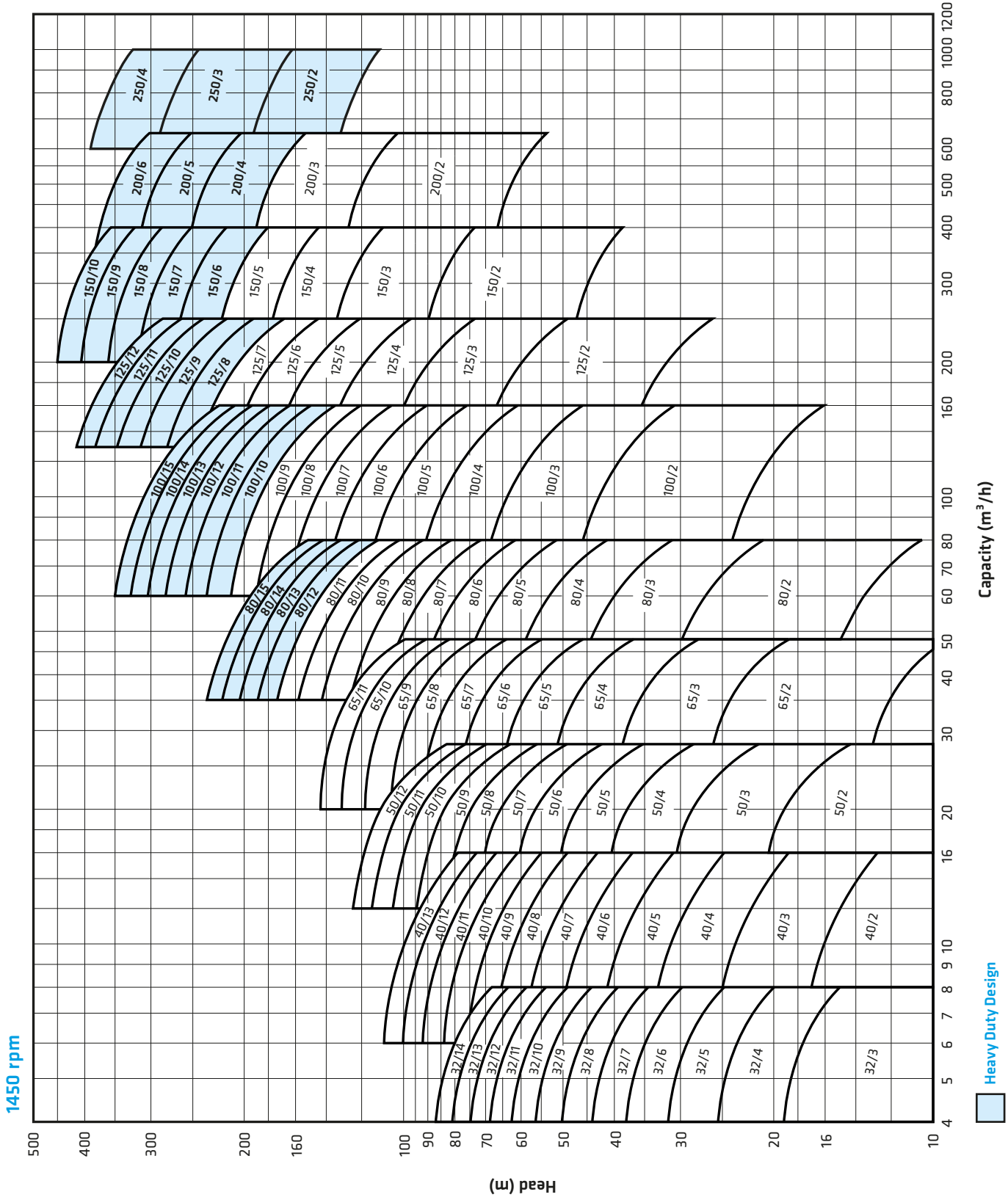

Field Chart

1450 rpm

Narrow Impellers

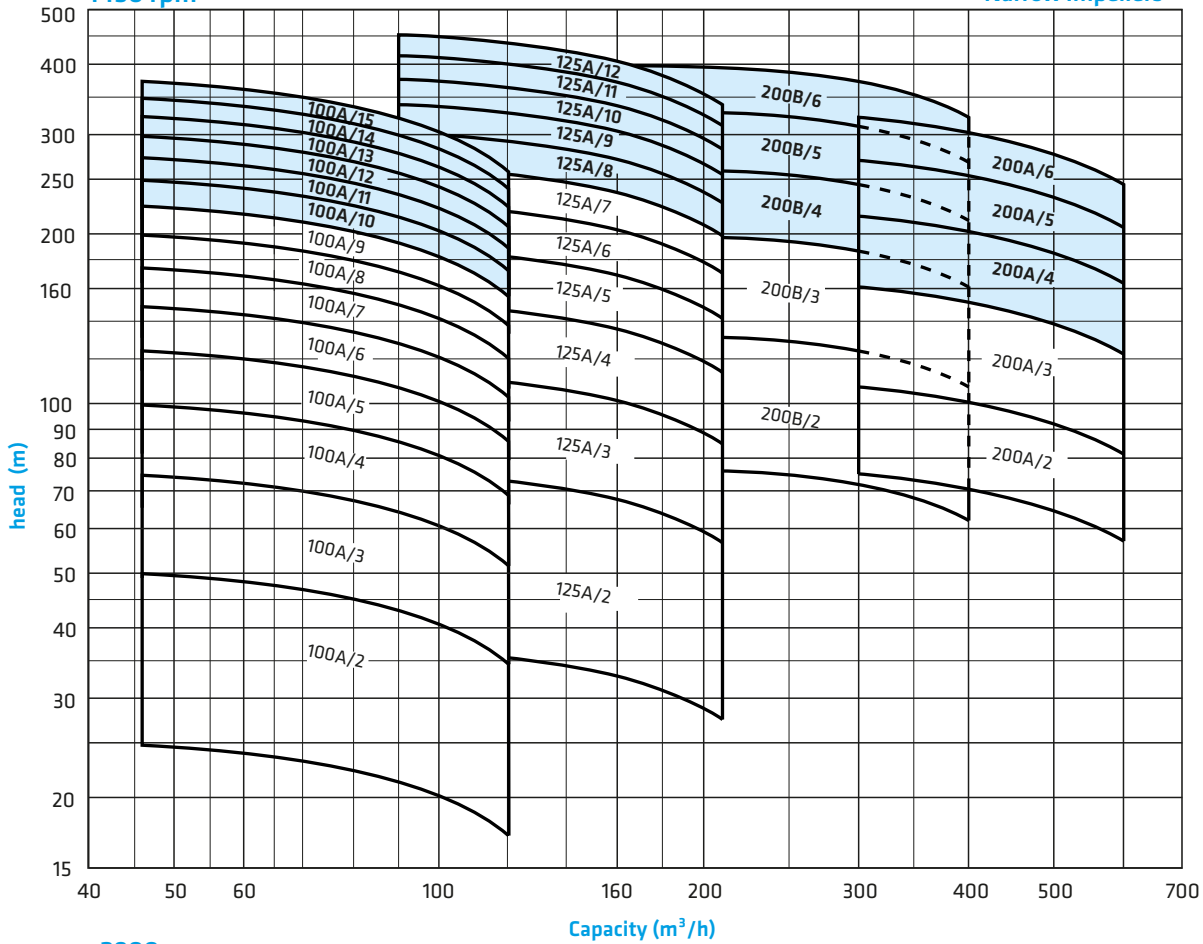

2900 rpm

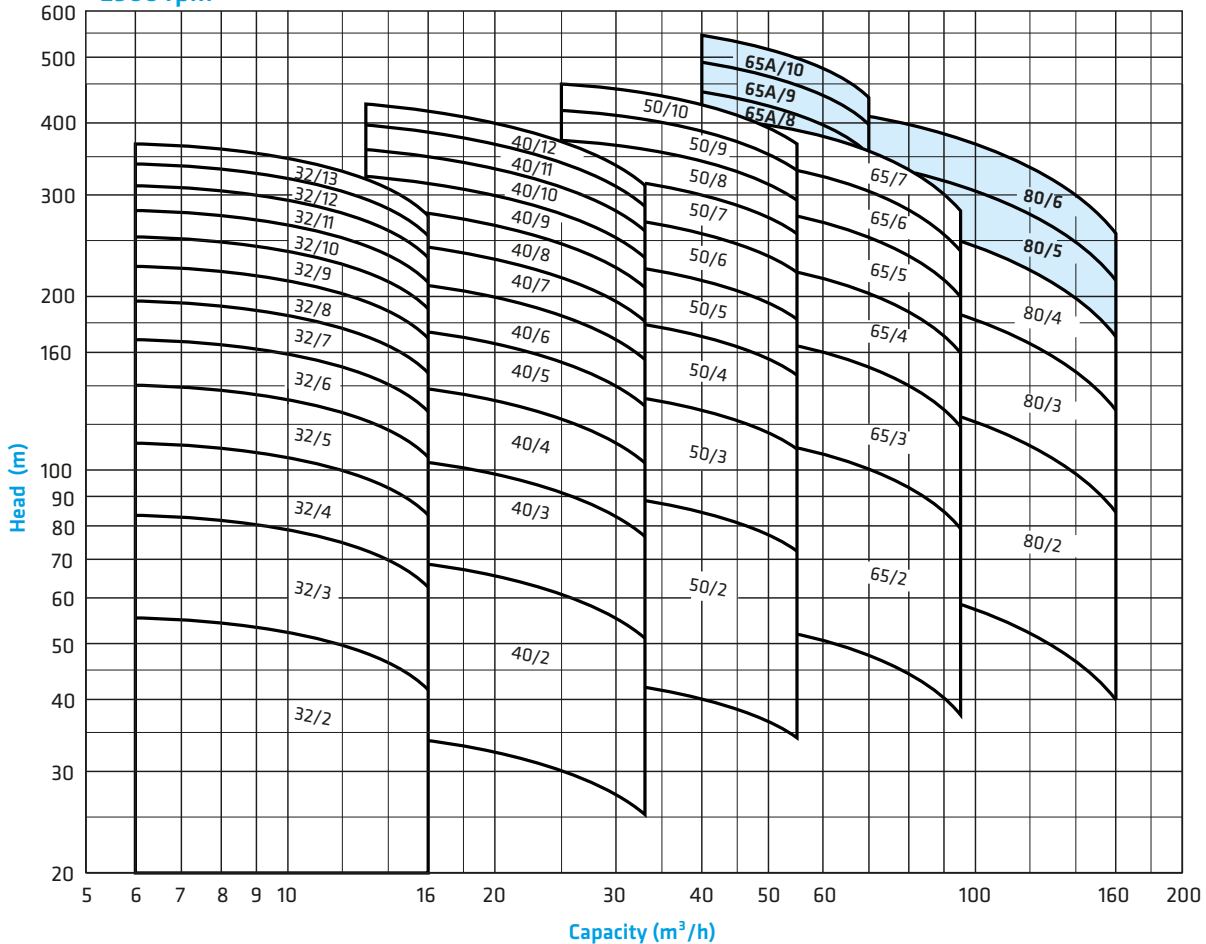

Heavy Duty Design

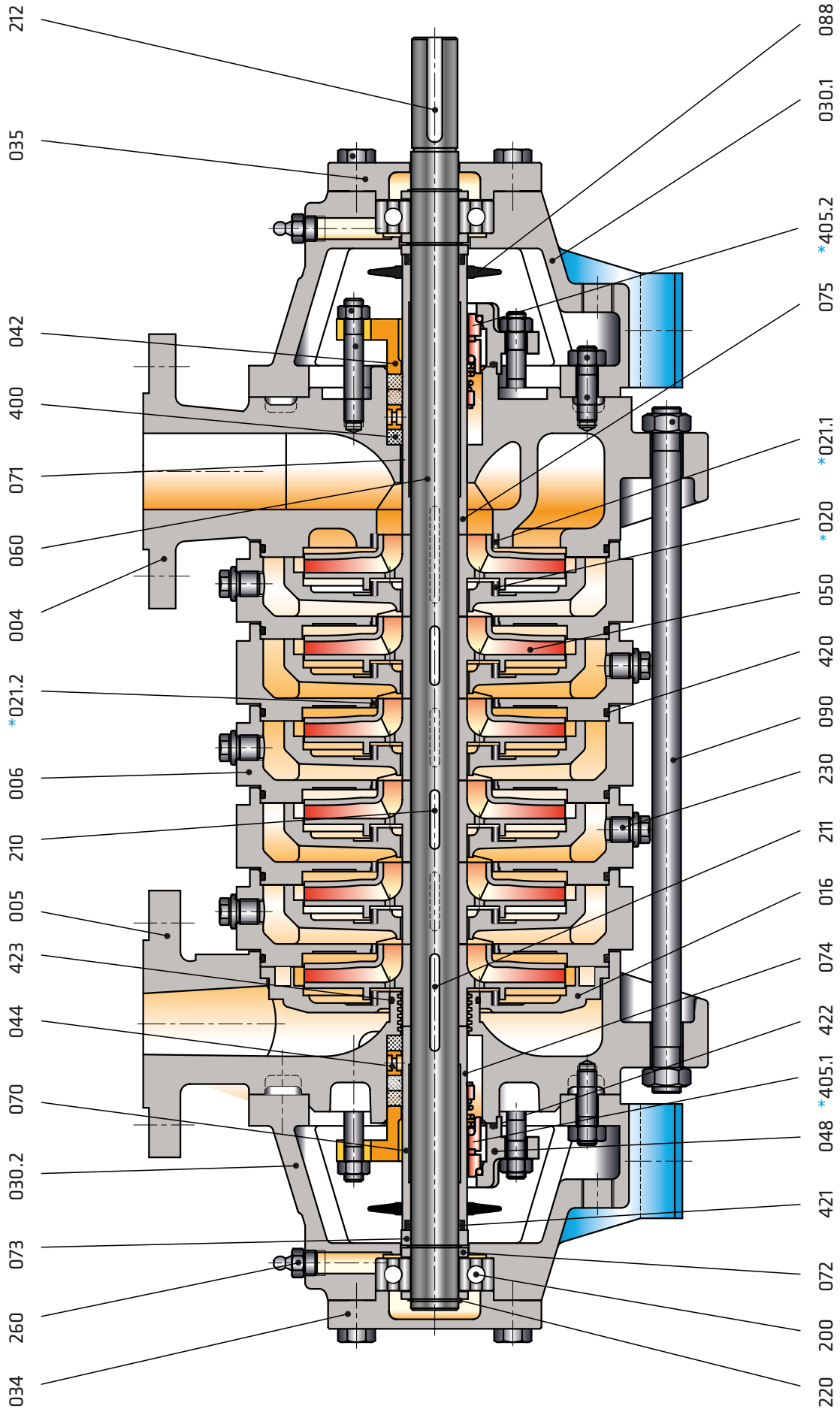

SKM - 80 - 100 - 125 - 150 - 200 - 250 Series

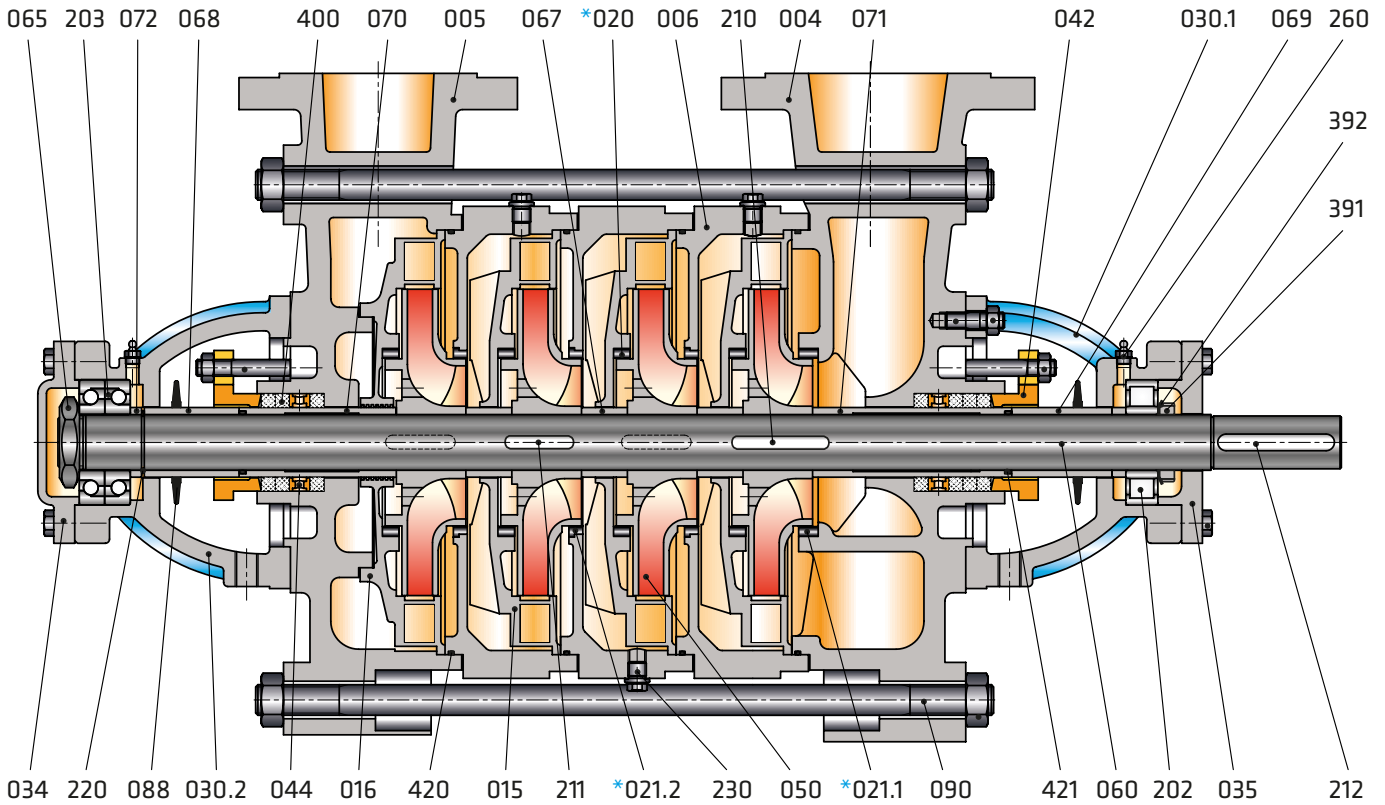

Part List

004	Suction Casing	072	Spacer Sleeve (discharge side)
005	Discharge Casing	073	Spacer Sleeve
006	Stage Casing	074	Mechanical Seal Sleeve (discharge)
015	Diffuser	075	Mechanical Seal Sleeve (suction)
016	Final Stage Diffuser	088	Thrower
*020	Wear Ring (stage casing)	090	Casing Tiebolt
*021.1	Wear Ring (suction casing)	200	Ball Bearing
*021.2	Wear Ring (stage casing)	202	Cylindrical Roller Bearing
030.1	Bearing Housing (suction casing)	203	Angular Contact Ball Bearing
030.2	Bearing Housing (discharge casing)	210	Impeller Key
034	Bearing End Cover	211	Stage Key
035	Bearing Cover (coupling side)	212	Coupling Key
042	Stuffing Box Gland	220	Retaining Ring
044	Lantern Ring	230	Drain Plug
048	Mechanical Seal Cover	260	Grease Nipple
050	Impeller	391	Shaft Nut
060	Shaft	392	Lock Washer
065	Shaft Nut	400	Stuffing Box Packing
067	Interstage Sleeve	*405.1	Mechanical Seal (Discharge)
068	Spacer Sleeve (discharge side)	*405.2	Mechanical Seal (Suction)
069	Spacer Sleeve (suction side)	420	O-Ring (stage casing)
070	Shaft Protecting Sleeve (discharge side)	421	O-Ring (shaft protecting sleeve)
071	Shaft Protecting Sleeve (suction side)	422	O-Ring (mechanical seal cover)
		423	O-Ring (discharge casing)

* Optional

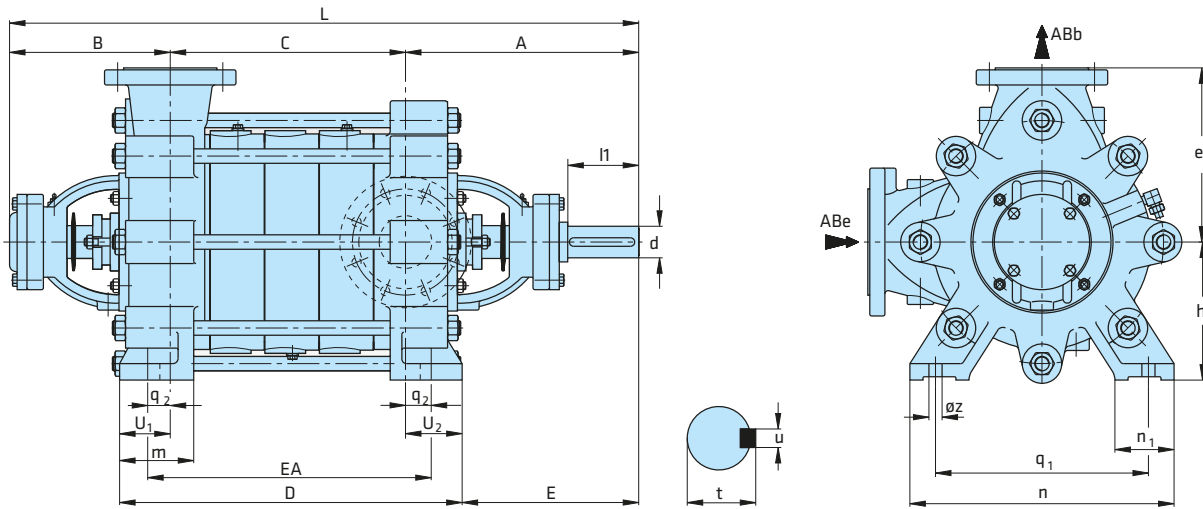

“C” according to the number of stages (mm)

Pump Type	1	2	3	4	5	6	7	8	9	10	11	12	13	14	15
32	71	114	157	200	243	286	329	372	415	458	501	544	587	630	
40	78	133	188	243	298	353	408	463	518	573	628	683	738		
50	90	152	214	276	338	400	462	524	586	648	710	772			
65	107	178	249	320	391	462	533	604	675	746	817				
80	112	195	278	361	444	527	610	693	776	859	942	1025	1108	1191	1274
100	133	233	333	433	533	633	733	833	933	1033	1133	1233	1333	1433	1533
125	165	280	395	510	625	740	855	970	1085	1200	1315	1430			
150	218	363	508	653	798	943	1088	1233	1378	1523					
200	267	437	607	777	947	1117									
250		520	722	924											

Pump Type	Dimensions (mm)																	
	ABe	ABb	A	B	EA	D	L	E	e	h	m	n	n1	q1	q2	øz	u1	u2
32	40	32	241	165	C+170	C+205	C+406	145	152	132	60	192	55	136	85	15	98,5	106,5
40	50	40	238	165	C+173	C+219	C+403	134	175	160	60	232	55	175	86,5	15	109,5	109,5
50	65	50	254	175	C+183	C+230	C+429	145	190	160	60	256	60	200	91,5	15	117	113
65	80	65	271	195	C+190	C+234	C+466	150	215	180	60	294	60	240	95	15	124	120
80	100	80	321	250	C+84	C+124	C+571	259	265	210	85	410	90	340	42	15	62	62
100	125	100	389	285	C+104	C+140	C+674	319	300	250	90	450	90	370	48	15	70	70
125	150	125	412	300	C+110	C+124	C+712	332	375	300	105	560	105	450	55	20	83	83
150	200	150	486	360	C+130	C+208	C+846	381	425	350	130	655	110	550	65	26	103	105
200	250	200	515	385	C+138	C+210	C+900	410	500	400	130	675	120	550	65	27	105	105
250	300	250	708	444	C+148	C+260	C+1152	577	627	472	155	775	150	625	74	32	130	129

Note : All rights reserved.

Heavy Duty Design

Flange Dimensions

EN 1092 - 2	DNe/DNb	Suction & Discharge (PN 16)				Suction & Discharge (PN 40)			
		Df	k	s	n	Df	k	s	n
		32	140	100	19	4	140	100	19
40	150	110	19	4	150	110	19	4	
50	165	125	19	4	165	125	19	4	
65	185	145	19	4	185	145	19	8	
80	200	160	19	8	200	160	19	8	
100	220	180	19	8	235	190	23	8	
125	250	210	19	8	270	220	28	8	
150	285	240	23	8	300	250	28	8	
200	340	295	23	12	375	320	31	12	
250	405	355	28	12	450	385	34	12	
300	460	410	28	12	515	450	34	16	

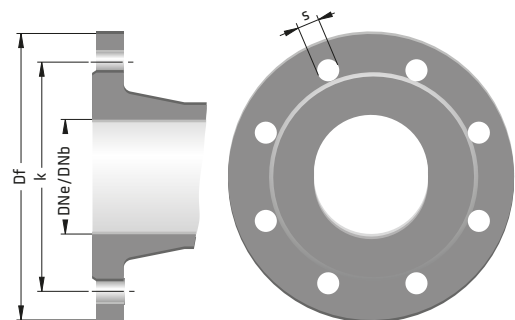

“ n ” number of holes

Standard Application

Pump Type	Shaft End				Weight (kg)	
	d1	l1	v	u	G1	g
32	24	60	27	8	44	6
40	24	60	27	8	58	9,5
50	28	65	31	8	89	13
65	32	65	35	10	92	20
80	38	80	41	10	128	26
100	42	110	45	12	177	42
125	48	110	51,5	14	330	75
150	55	110	59	16	580	120
200	70	140	74,5	20	920	200

Pump weight = G1 + (s x g) (s : number of stage)

Maximum number of stages according to shaft material

Pump Type	1.4462 / 1.4021		1.4301 / 1.4401	
	1450 rpm (1750 rpm)	2900 rpm (3500 rpm)	1450 rpm (1750 rpm)	2900 rpm (3500 rpm)
32	14(14)	13(9)	14(14)	13(8)
40	13(13)	12(8)	13(13)	7(3)
50	12(12)	10(6)	12(10)	7(2)
65	11(11)	7(4)	11(8)	5(2)
80	11(11)	4(2)	11(8)	3(N/A)
100	9(7)	-	6(4)	-
125	7(5)	-	4(2)	-
150	5(3)	-	3(N/A)	-
200	3(2)	-	3(N/A)	-

Heavy Duty Design

Pump Type	Shaft End				Weight (kg)	
	d1	l1	v	u	G1	g
65A	38	65	41	10	105	20
80	42	80	45	12	146	26
100	48	110	51,5	14	205	42
125	55	110	59	16	370	75
150	65	110	69	18	630	120
200	70	140	74,5	20	945	200
250	100	220	106	28	1250	320

Pump weight = G1 + (s x g) (s : number of stage)

Maximum number of stages according to shaft material

Pump Type	1.4462 / 1.4021		1.4301 / 1.4401	
	1450 rpm (1750 rpm)	2900 rpm (3500 rpm)	1450 rpm (1750 rpm)	2900 rpm (3500 rpm)
65A	-	10(7)	-	N/A
80	15(15)	6(3)	15(N/A)	N/A
100	15(11)	-	N/A(N/A)	-
125	12(8)	-	8(N/A)	-
150	10(6)	-	7(N/A)	-
200	6(4)	-	5(N/A)	-
250	4(3)	-	4(N/A)	-

Bearing Type

Standard Application

1450 rpm (1750 rpm)

Pump Type	Number of Stages	Bearing Type	
		Suciton	Discharge
32	2...14(14)	6305	6305
40	2...13(13)	6305	6305
50	2...12(12)	6306	6306
65	2...11(11)	6307	6307
80	2...11(11)	NU 308	3308
100	2...9(7)	NU 309	3309
125	2...7(5)	NU 310	3310
150	2...5(3)	NU 312	3312
200	2...3(2)	NU 315	2x7315

2900 rpm (3500 rpm)

Pump Type	Number of Stages	Bearing Type		Number of Stages	Bearing Type	
		Suciton	Discharge		Suction	Discharge
32	2...9(6)	6305	6305	10(7)...13(9)	NU 305	6405
40	2...6(4)	6305	6305	7(5)...12(8)	NU 305	6405
50	2...5(3)	6306	6306	6(4)...10(6)	NU 306	6406
65	2...4(2)	6307	6307	5(3)...7(4)	NU 307	6407
80	-	-	-	2(2)...4(2)	NU 308	3308

Heavy Duty Design

1450 rpm (1750 rpm)

Pump Type	Number of Stages	Bearing Type	
		Suction	Discharge
80	11(11)...15(15)	NU 309	2 x 7309
100	9(9)...15(11)	NU 310	2 x 7310
125	7(7)...12(8)	NU 312	2 x 7312
150	5(5)...10(6)	NU 314	2 x 7314
200	3(3)...6(4)	NU 316	2 x 7316
250	2(2)...4(3)	NU 321	2 x 7321

2900 rpm (3500 rpm)

Pump Type	Number of Stages	Bearing Type	
		Suction	Discharge
65A	8(N/A)...10(N/A)	NU 308	2 x 7308
80	5(N/A)...6(N/A)	NU 309	2 x 7309

PART LIST	0.6025	0.7040	0.7043	1.0619	1.4308	1.4309	1.4408	1.4409	1.4500	1.4517	1.4469	1.4317	1.4008	2.1050.01	2.0975.01	2.1096.01	1.0503	1.4021	1.4021+QT	1.4301	1.4404	1.4460	1.4462	
Suction Casing	●	○	○		○	○	○	○	○	○	○	○	○	○										
Discharge Casing	●	○	○		○	○	○	○	○	○	○	○	○	○										
Stage Casing	●	○	○		○	○	○	○	○	○	○	○	○	○										
Diffuser	●	○	○	○	○	○	○	○	○	○	○	○	○	○	○	○								
Impeller	●	○	○	○	○	○	○	○	○	○	○	○	○	○	○	○							○	
Shaft																		●	○	○	○			○
Bearing Housing	●	○	○	○	○	○	○	○																
Wear Ring	○	○	○	○	○	○	○	○	○	○	○	○	○	○	○	○								
Spacer Sleeve																	●	○	○	○	○			○
Shaft Protecting Sleeve																	●	○	○	○	○			○
Interstage Sleeve																	●	○	○	○	○			○
Mechanical Seal (*)	EN 12756																							

(*) Optional :Depending on customer requirement or request different types and brands of mechanical seals are applicable. ● Standard manufacturing ○ Optional

Material Equivalents

Description	DIN / EN	AISI / SAE / ASTM	
Cast Iron	0.6025	EN-GJL-250 (GG25)	A48 Class 40B
Nodular Cast Iron	0.7040	EN-GJS-400-15 (GGG40)	A536 60-40-18
Nodular Cast Iron	0.7043	EN-GJS-400-18-LT (GGG40.3)	A536 60-40-18
Cast Steel	1.0619	GP240GHGS-C25	A216 WCB
Chrome Nickel Cast Steel	1.4308	GX5CrNi19-10	A351 CF8
Chrome Nickel Cast Steel (low carbon)	1.4309	GX2CrNi19-11	A351 CF3
Chrome Nickel Molybdenum Cast Steel	1.4408	GX5CrNiMo19-11-2	A351 CF8M
Chrome Nickel Molybdenum Cast Steel (low carbon)	1.4409	GX2CrNiMo19-11-2	A351 CF3M
Austenitic Cast Steel	1.4500	GX7NiCrMoCuNb25-20	A351 CN7M
Austenitic - Ferritic Cast Steel (duplex)	1.4517	GX2CrNiMoCuN25-6-3-3	A890 CD4MCuN
Austenitic - Ferritic Cast Steel (super duplex)	1.4469	GX2CrNiMoN26-7-4	A890 CE3MN
Martenzitic Stainless Cast Steel	1.4317	GX4CrNi13-4	A352 CA6NM
Martenzitic Stainless Cast Steel	1.4008	GX7CrNiMo12-1	A217 CA15
Cast Bronze (tin alloy)	2.1050.01	G-CuSn10	B427 C90700
Cast Bronze (nickel alloy)	2.0975.01	G-CuAl10Ni	B148 C95500
Cast Bronze (lead)	2.1096.01	G-CuSn5ZnPb	B584 C83600
Carbon Steel	1.0503	C45	AISI 1045
Chrome Steel	1.4021	X20Cr13	A276 Type 420
Chrome Steel (heat treated)	1.4021	X20Cr13	A276 Type 420+QT
Chrome Nickel Steel	1.4301	X5CrNi18-10	A276 Type 304
Chrome Nickel Steel (low carbon)	1.4404	X2CrNiMo17-12-2	A276 Type 316L
Duplex (austenitic-ferritic) Steel	1.4460	X3CrNiMoN27-5-2	AISI 329
Duplex (austenitic-ferritic) Steel	1.4462	X2CrNiMoN22-5-3	UNS S32205

Flange Positions

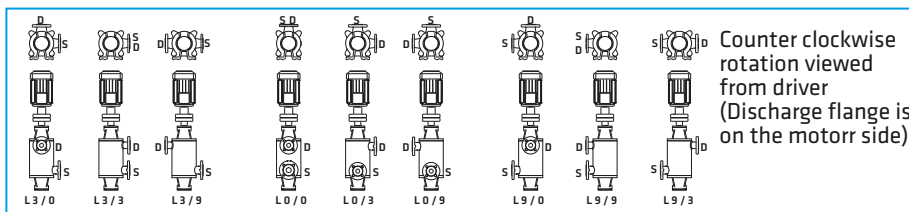
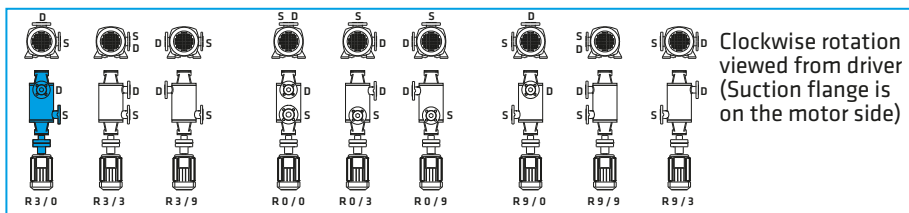

R 3/0

Discharge Flange Position (D)
Suction Flange Position (S)
Direction of Rotation (R/L)

Direction of rotation viewed from driver end
R : Right
L : Left