

# Magnetic Drive Hot Oil Gear Pump

Our Hot Oil Gear Pump is a robust solution designed for pumping viscous liquids with suspended impurities, specifically engineered to endure elevated process temperatures.

These Volumetric Gear Pumps are known for their reliability, ensuring a steady, pulse-free flow, and delivering impressive differential pressures.

Additionally, the precision-engineered internal components provide accurate and repeatable performance over time.

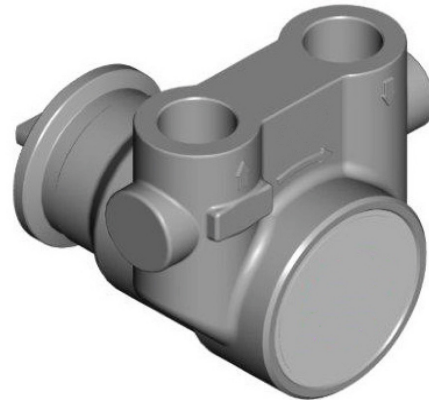

## MAIN APPLICATIONS

- Fryer machines

## TECHNICAL INFORMATION

Pump housing material	Cast Iron G25	Wet lift with water*	> 6 m
Gears and bushing material	Hastelloy	Speed range	from 250 to 3500 rpm
Ports	1/2" GAS	Max output power	250 W
Max static pressure	20 bar/290 psi	Unit weight	1.866 Kg
Min7max fluid temperature	5/250 °C - 41/482 F		

\* Priming ability varies with operating conditions and fluid characteristics

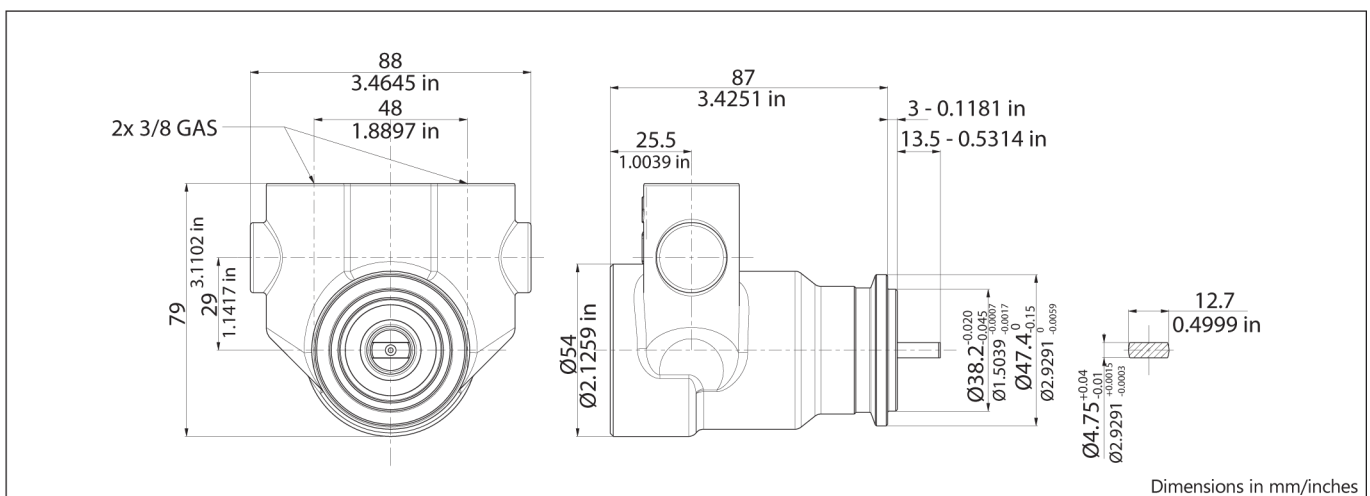

» HIGH TEMPERATURE GEAR PUMP

???? – 8mm – White oil 22cSt

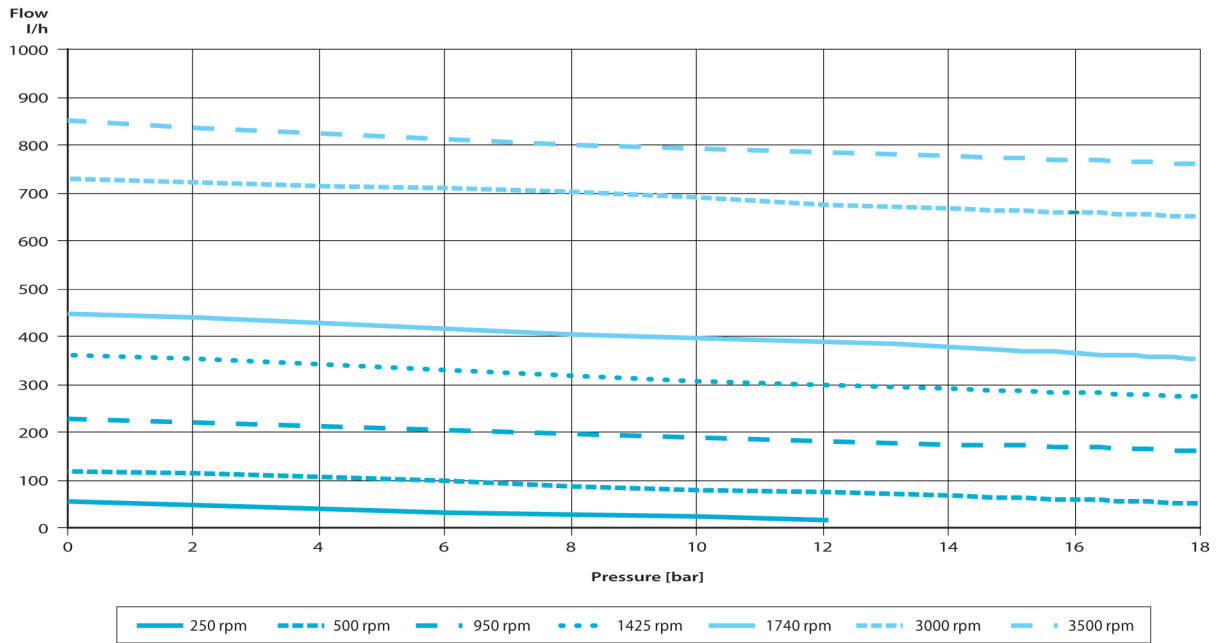

???? – 16 mm – White oil 22cSt

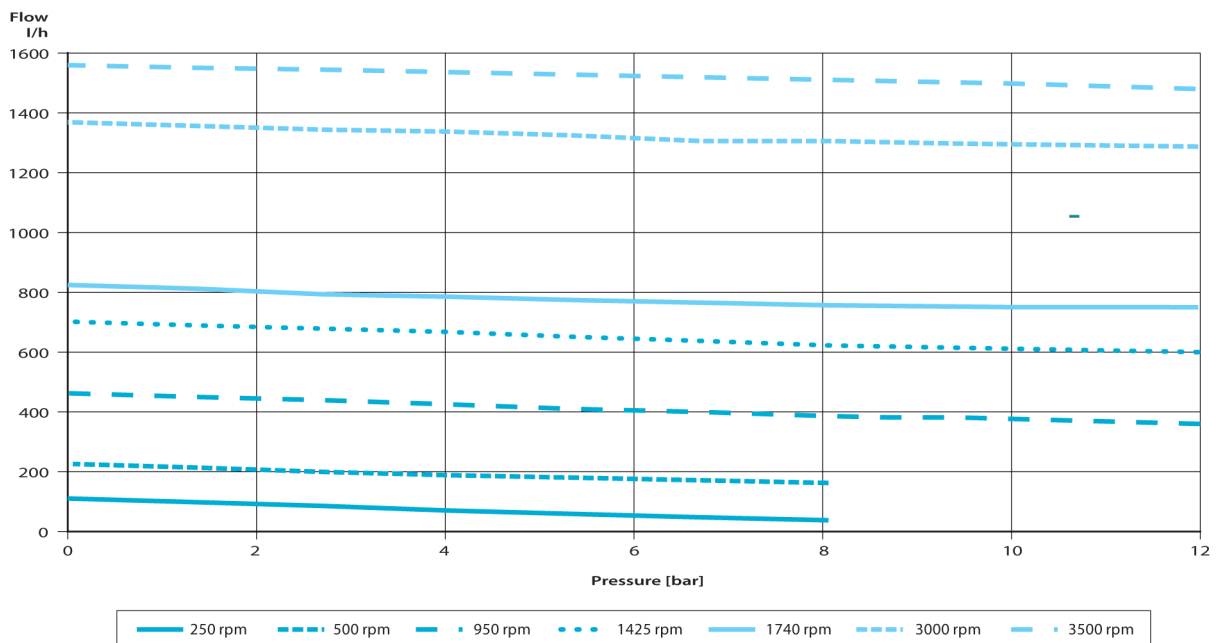

Note: Nominal motor speed 4000 RPM.