

IOM manual

tapflo®

# HVS FLEXI

Original Instruction  
2023 | 1



Read the instructions carefully before installing and commissioning the system



» All about your flow®

[www.tapflo.pl](http://www.tapflo.pl)

# CONTENTS

---

<b>0. GENERAL</b> .....	5
<b>0.1. Introduction</b> .....	5
<b>0.2. Warning symbols</b> .....	5
<b>0.3. Qualification and training of personnel</b> .....	6
<b>0.4. List of standards and referenced documents</b> .....	6
<b>1. DEVICE DESCRIPTION</b> .....	7
<b>1.1. General description of the device</b> .....	7
<b>1.2. Technical characteristics and operating parameters of the unit</b> .....	7
<b>1.3. Unit drawing</b> .....	8
<b>1.4. Unit components</b> .....	8
<b>1.5. Design calculation and pump selection</b> .....	8
<b>2. INSTALLATION</b> .....	9
<b>2.1. General safety rules</b> .....	9
<b>2.2. Purpose and scope of application</b> .....	10
<b>2.3. Receiving inspection</b> .....	10
<b>2.4. Lifting and transportation</b> .....	10
<b>2.5. Storage</b> .....	11
<b>2.6. Health and safety</b> .....	11
<b>2.6.1. Protection</b> .....	11
<b>2.6.2. Potentially explosive environment - ATEX</b> .....	11
<b>2.6.3. Electrical safety</b> .....	12
<b>2.6.4. Chemical hazards</b> .....	12
<b>2.6.5. Washing the unit</b> .....	12
<b>2.6.6. Noise level</b> .....	12
<b>2.6.7. Temperature</b> .....	12
<b>2.6.8. Rotating or moving parts</b> .....	12
<b>2.7. Feeding the medium into the system</b> .....	12
<b>2.8. Assembly</b> .....	13
<b>2.8.1. Installation of the device on the floor</b> .....	13
<b>2.8.2. Connecting the unit to the suction and discharge system</b> .....	13
<b>3. OPERATION</b> .....	14
<b>3.1. Before starting the unit</b> .....	14
<b>3.2. First startup</b> .....	14
<b>3.2.1. Before commissioning</b> .....	14
<b>3.2.2. First startup</b> .....	14

# CONTENTS

---

3.2.3.	Control panel Layout .....	15
3.3.	Operating the System .....	16
3.3.1.	Mode "0" - Actuator .....	16
3.3.2.	Mode "1" - Barrel .....	16
3.4.	Electronic controller .....	16
3.4.1.	Electronic controller panel .....	16
3.4.2.	Main panel .....	17
3.4.3.	Pump speed panel .....	18
3.4.4.	Settings .....	18
3.4.5.	Alarms .....	19
3.5.	Pneumatic Control .....	21
3.5.1.	Air Filter-Regulator .....	21
3.5.2.	Max Piston Position sensor .....	21
3.5.3.	Min. Piston Position sensor .....	22
3.5.4.	Lifting up speed .....	22
3.5.5.	Lowering down speed .....	22
4.	MAINTENANCE .....	24
4.1.	Operating conditions .....	24
4.2.	General guidelines .....	24
4.3.	Inspection and periodical checks .....	24
4.4.	Operation of individual equipment .....	25
4.5.	Shutting down and flushing the unit .....	25
4.6.	Troubleshooting .....	25
4.7.	Identification of hazards arising during use of the dosing unit .....	25
5.	DISPOSAL .....	26
5.1.	Disposal after expiration of the expected lifetime .....	26
5.2.	Waste of electrical and electronic equipment (WEEE) directive .....	26
6.	SPARE PARTS .....	27
6.1.	Spare parts description .....	27
6.2.	How to order parts .....	27
7.	APPENDICES .....	28
8.	WARRANTY .....	29
8.1.	Returning parts .....	29
8.2.	Warranty .....	29

# 0. GENERAL

---

## EU DECLARATION OF CONFORMITY

Series: **HVS**

Model: **HVS FLEXI**

Serial number: **23.243**

Manufactured by Tapflo Sp. z o.o., Poland for:

**Tapflo Group AB**

**Filaregatan 4**

**S-442 34 Kungälv, Sweden**

This declaration of conformity is issued under the sole responsibility of the manufacturer.

Object of declaration: **HVS FLEXI with Jessberger JP-700L. 50L DR**

The object of the declaration described above is in conformity with the relevant Union harmonization legislation:

- Directive 2006/42/EC of European Parliament and of the Council of 17 May 2006 on machinery;

Signed for and on behalf of  
Tapflo Group AB, 16.10.2023



Per Antonsson  
Chief Executive Officer

# 0. GENERAL

## 0. GENERAL

### 0.1. Introduction

This IOM manual have been developed for a mobile system equipped with a Jessberger JP-700L.50L GM 1200 pump. This system is designed to unload barrels and IBC tanks.

Detailed information on the operation of individual devices can be found in individual instructions for operation and use, which are an integral part of the unit's documentation. This documentation contains information on the application, construction, operation and use of the unit. It is intended for the operating personnel and technical services of the user. The user should be aware of the need to thoroughly read this manual and follow the regulations and recommendations contained therein. The information included in this manual is subject to change without notice and does not constitute a commitment on the part of Tapflo.







With proper attention to maintenance, Tapflo Products will give efficient and trouble-free operation. This instruction manual will familiarize operators with detailed information about installing, operating and maintaining of the unit.

### 0.2. Warning symbols

The following warning symbols are present in this manual:

	Risk of danger to life or health.
	General sign of mandatory activity.
	Read the instruction manual.
	Use hearing protection.
	Use face protection.
	Use respiratory protection.
	Wear protective gloves.
	Wear protective footwear.
	Connect the grounding.

## 0. GENERAL

	Danger caused by the presence of an electric field or live wires.
	Risk of hand injury.
	Danger caused by the presence of a corrosive substance.
	Risk of head injury.
	Explosion hazard area (ATEX) warning.
	Climbing onto the unit is prohibited.

### 0.3. Qualification and training of personnel



The personnel in charge of installation, operation and maintenance of the dosing units must be qualified to carry out the operations described in this manual. Tapflo shall not be held responsible for the training level of personnel and for the fact that they are not fully aware of the contents of this manual. In case any instructions in this manual are unclear or any information is lacking, please contact Tapflo before handling the unit.

### 0.4. List of standards and referenced documents

- In accordance with the requirements of Directive 2014/68/EU (Pressure Directive / PED), a categorical evaluation of the equipment was carried out. In accordance with this procedure, the unit was manufactured based on recognized engineering practice (Regulation of the Minister of Development of July 11, 2016, on essential requirements for pressure equipment and assemblies of pressure equipment - §10).
- Directive 2006/42/EC (Machinery Directive) of the European Parliament and of the Council dated May 17, 2006,
- EN ISO 12100 Safety of machinery - General principles for design - Risk assessment and risk reduction,
- PN-EN 809+A1:2009 Pumps and pump units for liquids - General safety requirements
- Regulation of the Minister of Economy dated October 21, 2008, on essential requirements for machines (Journal of Laws No. 199 item 1228),
- Act of August 30, 2002, on the conformity assessment system ( Official Journal of Laws of October 7, 2002, No. 166, item 1360, in force together with subsequent amendments from January 1, 2003; Journal of Laws No. 80, item 718, No. 130, item 1188 and No. 170, item 1652 of 2003),
- Project Documentation No. 23.214

# 1. DEVICE DESCRIPTION

---

## 1. DEVICE DESCRIPTION

### 1.1. General description of the device

The mobile unit for unloading barrels and IBC containers consists of a mobile frame with integrated lifting device that elevate pump above the tanks. This unit also is equipped with control cabinet for proper operation of the unit.

The discharge port of the pumped medium should be connected to the user's hose or discharge installation.

The mobile unit is equipped with a pneumatic actuator, which lifts the pump above barrel or IBC container and allows user to change tanks.

In addition, the unit is equipped with a Control cabinet that allows to operate pump and pneumatic actuator. Frequency inverter allows to change pumping speed of the pump.



The mobile unit **must not be used** in explosive environments (ATEX).

### 1.2. Technical characteristics and operating parameters of the unit

Series:	Mobile Unit
Serial no.:	23.243
Working medium:	Tomato paste
Max. installation size:	DN40
Max. discharge pressure:	2 barg
Max. flow rate:	1 200 l/h
Max. medium temperature Tmax:	+50 °C
Min. medium temperature Tmin:	+ 5 °C

# 1. DEVICE DESCRIPTION

## 1.3. Unit drawing

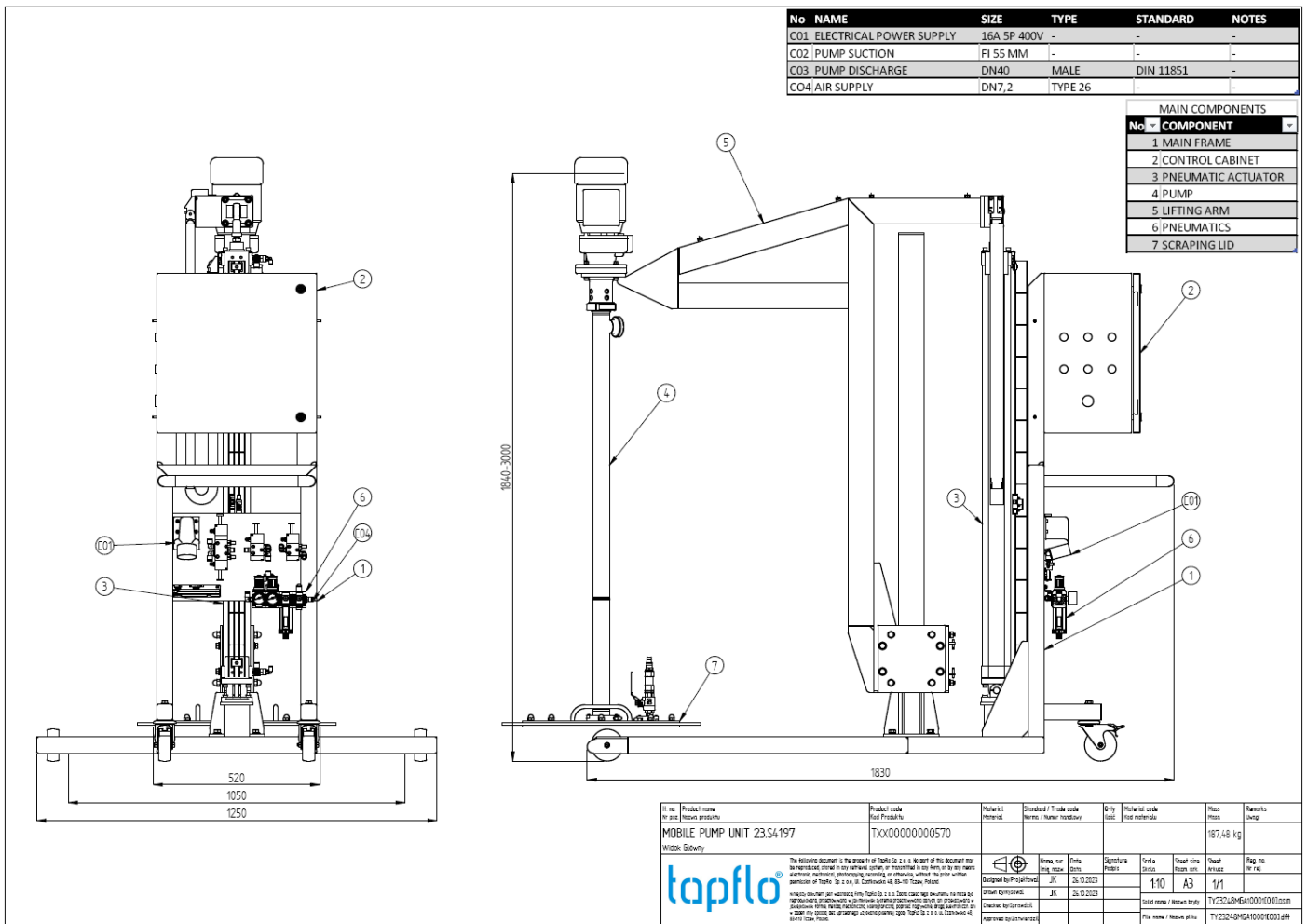

Fig. 1: Drawing and marking of unit elements.

## 1.4. Unit components

Tab. 1: List of unit components.

Pos.	Description
1	Main Frame
2	Control Cabinet
3	Pneumatic Actuator
4	Pump
5	Lifting Arm
6	Pneumatics
7	Scraping Lid

## 1.5. Design calculation and pump selection

The design calculations of pressure and flow values were made based on the parameters required for a specific technological process, which were provided by the customer. Based on these values, the pump and other system components were selected. The assembly materials of the unit components were selected based on the Design Guidelines and the experience of the system user.



## 2. INSTALLATION

---

### 2. INSTALLATION

#### 2.1. General safety rules



Health and safety regulations must be observed when performing repairs and renovations.



If repairs are made to the hydraulic system, it must be brought to a non-pressurized state.



All persons who use the pumping system or carry out maintenance and service work should undergo appropriate training followed by verification of competence.



During repairs, damaged parts should be replaced only with original spare parts.



For failures and damage and legal consequences resulting from failure to comply with the recommendations contained in this manual and related documentation, the manufacturer assumes no responsibility.



Modifications to the design not approved by Tapflo and the use of spare parts that do not meet the manufacturer's specifications may damage the pumping system, void the warranty, the certificate and, above all, compromise the safety of those operating the unit.



The unit **must not be used** in explosive environments (ATEX).



This manual is an integral part of the device. It should be available throughout the life of the system until disposal and scrapping.



When operating the pumping system, strictly follow the recommendations of the regulations applicable to machinery and equipment.



Service of pumping systems is provided by the Manufacturer.



Electrical components may be connected or repaired only by authorized persons.

## 2. INSTALLATION

---



In the interest of health and safety, it is essential to wear gloves, face protection and a helmet.



Health and safety markings should be visible on the layout at all times. If they are torn off, the user should glue/install new ones.

### 2.2. Purpose and scope of application

The system is intended only for the application for which the unit has been selected. The unit should not be used for any other application without written confirmation from Tapflo.

The use of the unit is allowed only within the permissible flow, pressure and temperature limits and taking the chemical and corrosive effects into account.

Any use of the unit outside the specified limits and specifications is considered to be not in accordance with the intended use. Any resulting damage is not the responsibility of the manufacturer. The user will bear the entire risk of misuse of the system.

### 2.3. Receiving inspection

Although precaution is taken by us when packing and shipping, we urge you to carefully check the shipment on receipt. Make sure that all parts and accessories listed on the packing list are accounted for. Any shipment shortages or damage should be reported to Tapflo and the shipping company.

### 2.4. Lifting and transportation

Pump systems should be transported in their entirety. During transport, it is required to protect all hydraulic connections from the ingress of any debris. The unit can be transported by means of the intended transport brackets in the upper part of the frame or eyebolts screwed into the feet on the frame of the system. During transport, the system should be moved parallel to the ground, with special attention to possible damage to system components.

Each time after transportation, the unit must be checked for leaks.

If a leak is detected, it is not permitted to use the unit until the defect is repaired.



When transporting pumping systems, pay special attention to the correct attachment of slings and hooks.



It is forbidden to be directly under the suspended unit.



When carrying out transportation work, it is necessary to follow the rules of health and safety.

## 2. INSTALLATION

---



When transporting the system, it is forbidden to lift it by electric, hydraulic or pneumatic lines.

### 2.5. Storage



If the device is to be stored before installation, store it in a clean place. Clean the unit before installation.

### 2.6. Health and safety

The device must be installed in accordance with local and national safety regulations.



Before starting the device, read the instruction manual.



Pay attention to the warning signs - danger of hand injury.



**The unit is constructed for particular applications. Do not use it on applications different from that for which it was sold without consulting us to ascertain its suitability.**

#### 2.6.1. Protection



In the interest of health and safety, it is essential to wear gloves, face protection, hearing protection and a helmet.



Health and safety markings should be visible on the unit at all times. If they are torn off, the user should glue/install new ones.

#### 2.6.2. Potentially explosive environment - ATEX



The unit **must not be used** in explosive environments (ATEX).

## 2. INSTALLATION

---

### 2.6.3. Electrical safety



Do not carry out any maintenance work on the device while it is in operation and when the electrical power supply has not been disconnected. Prevent electrical hazards (see regulations for the use of electrical equipment). Check that the electrical specifications on the nameplate correspond to the parameters of the mains supply.



Electrical components may be connected or repaired only by authorized persons.

### 2.6.4. Chemical hazards



Before servicing, make sure that there is no medium in the unit or any of its components.

### 2.6.5. Washing the unit



Keeping the unit clean plays a special role to keep unit in good condition for elongated period of time. Neglecting to clean the system risks accelerating the process of component wear.

### 2.6.6. Noise level



Tests of the Tapflo pumping system show that the noise level does not exceed 85 dB(A). In some cases, the noise level can be inconvenient or hazardous to people in the vicinity of the unit. Therefore, it is recommended to use appropriately selected individual noise protection measures.

### 2.6.7. Temperature



The permissible range of ambient temperature in which the unit operates is +5°C / +50°C. It is not allowed to operate the device at temperatures exceeding the range of permissible temperatures.

### 2.6.8. Rotating or moving parts



Do not tamper with the protection of rotating components, do not touch, or come close to rotating or moving components, such as the clutch, pump rotor or pump gearbox.

## 2.7. Feeding the medium into the system

Before starting work, the pump head must be submerged into the barrel or IBC tank filled with medium. Starting the pump that is not submerged in medium will cause damage to the pump. Tapflo assumes no responsibility for damage caused by improper condition of the unit to the pump suction, and in particular for damage caused by failure to ensure an adequate amount of medium in the supply tank.

## 2. INSTALLATION

---

### 2.8. Assembly

#### 2.8.1. Installation of the device on the floor

The device is designed as the mobile unit therefore no special assembly activities are needed. Unit is designed to operate on the hardened, level ground.

#### 2.8.2. Connecting the unit to the suction and discharge system

- Suction end of the pump must be submerged into the medium.
- Discharge connection of the pump must be connected to the users hose or piping.
- Check tightness of connections after connecting the unit.
- The size of the unit connections and standards are shown in the assembly drawing and in the point 1.3 Unit drawing – Fig 1. Drawing and marking of unit elements.

When connecting any of the unit's connections with the installation, take special care not to load the unit's connections with additional external forces during or after the work. Loading or damaging the connections of the system may lead to unsealing of the system. In such a case, it is the responsibility of the service department to keep the unit out of service and effectively repair the fault.



Tapflo assumes no responsibility for damage caused by improper connection of the system to the installation.

## 3. OPERATION

### 3. OPERATION

#### 3.1. Before starting the unit



In the interest of health and safety, it is essential to wear gloves, face protection and a helmet.



When starting service and installation work, make sure that the pressure in the installation is equal to the atmospheric pressure.

#### 3.2. First startup

##### 3.2.1. Before commissioning

- The unit must be connected to the piping system in accordance with the information given in section 2.8.2. of this manual.
- Before starting the unit, check the tightness of all connections.
- Make sure that there are no contaminants in the medium other than those agreed at the technical agreement stage (e.g., films, large solids, etc.).
- Make sure that the suction connection is submerged into medium.
- Make sure that the external parameters are appropriate (e.g., the outside temperature is not too low).

##### 3.2.2. First startup

It is recommended that the first startup of the unit should be made on the cleaning medium to make sure that pump is free from the contamination that might appear during transportation of the unit.

- Connect the 400VAC power supply to the system, below the control cabinet there is a 400V, 5p, 16A power plug;
- Connect the unit to the air supply;
- All circuit breakers (F1, F2, ...) inside the control cabinet should be switched on;
- Set the main switch Q1 to the "ON" position;
- Make sure that the safety button (ESTOP) is NOT pressed;
- Make sure that the ALARM lamp is off – the ALARM can be reset with RESET button. Read Error Messages and make sure that the error conditions have been removed prior to resetting the alarm (more information about alarm in point 3.4.5);
- Pressure sensor connection - if the device is not equipped with a pressure sensor, check whether a connection (jumper) is made between terminals 25 and 28.
- Level sensor connection - if the device is not equipped with a level sensor, check whether a connection (jumper) is made between terminals 29 and 32.

**Alarm Reset:** Alarm can be reset with RESET (S2) Button.

**Note:**

Before resetting the alarm, check the error code on the electronic controller display panel (point 3.4.5) and make sure that the problem source is removed.

# 3. OPERATION

**Safety button (ESTOP – S1):** Emergency stop of the system, this button stops the operation of the lift, and the operation of the pump.

Pressing the safety button causes an error to be displayed on the PLC panel and indicated by red Alarm lamp (H1);

**Note:**

It should be remembered that the safety button does not disconnect the power from the system, for this purpose the Main Switch is used, which is located on the side wall of the control cabinet, marked as Q1.

### 3.2.3. Control panel Layout

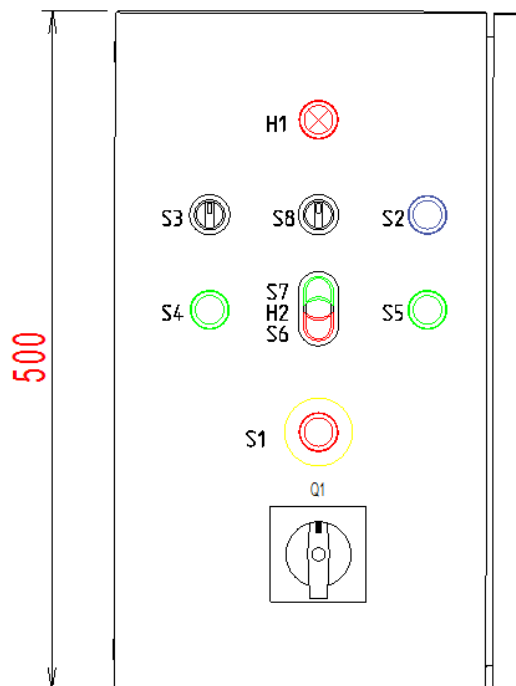

**Fig.2.** View of the control buttons

SIGNATURE	SYMBOL	DESCRIPTION
<b>ON/OFF SWITCH</b>	<b>Q1</b>	Main switch;
<b>E-STOP</b>	<b>S1</b>	Emergency stop button;
<b>RESET</b>	<b>S2</b>	Alarm reset;
<b>MODE SWITCH</b>	<b>S3</b>	Actuator / Barrel;
<b>HOLD TO MOVE</b>	<b>S4</b>	Hold the button to move actuator. Both buttons (S4, S5) must be pressed / Areation;
<b>HOLD TO MOVE</b>	<b>S5</b>	Hold the button to move actuator. Both buttons (S4, S5) must be pressed
<b>STOP</b>	<b>S6</b>	Stops pump work
<b>START</b>	<b>S7</b>	Starts pump work in different modes;
<b>UP / DOWN</b>	<b>S8</b>	Switch for Uplifting / Lowering
<b>ALARM</b>	<b>H1</b>	Alarm lamp indicator - RED;
<b>PUMP RUN</b>	<b>H2</b>	Work lamp indicator - GREEN;

# 3. OPERATION

---

## 3.3. Operating the System

### 3.3.1. Mode "0" - Actuator

This mode is used to fast change position of the actuator.

To activate "Actuator" mode the mode switch (S3) should be set at "ACTUATOR" position.

- **Lifting:** the switch (S8) should be set to the "UP" position, then press the green "HOLD TO MOVE" buttons (S4, S5) in parallel – as long as the buttons are pressed, the lift will float (until the upper end position is reached);
- **Lowering:** the switch (S8) should be set to the "DOWN" position, then press the green "HOLD TO MOVE" buttons (S4, S5) in parallel – as long as the buttons are pressed, the lift will be lowered (until the lower end position is reached);
- **Pump Work:** When the START button (S7) is pressed then the pump will start working (as long as button is pressed).

If actuator will reach the lower end position then START button (S7) will permanently turned on the pump. STOP button (S6) or lifting actuator up will stop the pump.

**NOTE:** When ESTOP button (S1) is pressed then lifter will not operate and the pump will not run, no matter the mode.

### 3.3.2. Mode "1" - Barrel

This mode is used to pump high viscosity liquids.

To activate "Barrel" mode the mode switch (S3) should be set at "BARELL" position.

- **Pump Work:** To start pumping it is needed to press the START button (S7), pump will start working and actuator will go down into the barrel. Actuator will stops when low level sensor is reached, pump will stops a few seconds later (time to stop pump is regulated). Pump and actuator can be sopped by STOP button (S6), or moving up actuator (switch (S8) to UP, and press "HOLD TO MOVE buttons (S4, S5));
- **Actuator move:** To move the actuator just switch (S8) to UP or DOWN mode and press HOLD TO MOVE buttons (S4, S5). Moving actuator UP will start aeration of the barrel.
- **Aeration of the barrel:** to start aeration of the barrel press green HOLD TO MOVE button (S4), as long as button is pressed aeration will work;

**NOTE:** When ESTOP button (S1) is pressed then lifter will not operate and the pump will not run, no matter the mode.

## 3.4. Electronic controller

### 3.4.1. Electronic controller panel

Electronic control panel view:



### 3. OPERATION

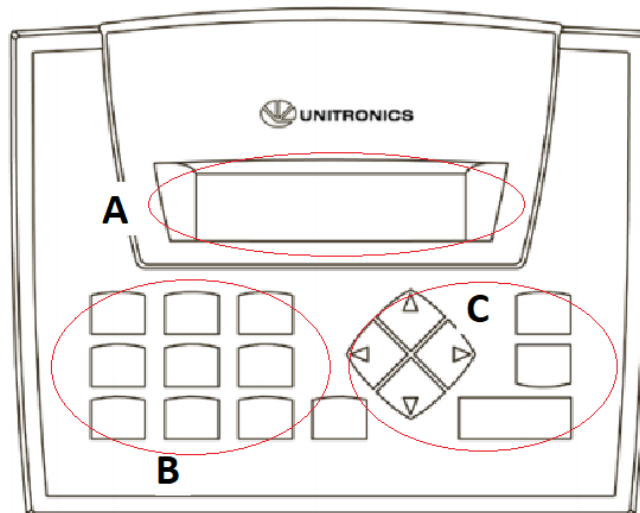



**Fig.3.** View of the electronic controller panel

SYMBOL	DESCRIPTION
A	2 line LCD display
B	Alphanumeric keyboard (0-9)
C	Function buttons; - arrows (←↑→↓) - information (i) - enter (↵)

#### 3.4.2. Main panel

Electronic controller with 2 line display is mounted inside the control cabinet at back of the door.

Main panel show basic information like:

- upper end position:  ;
- lower end position:  ;
- time to switch off the pump work if lower end position is reached (only in Barrel mode);



**Fig.4.** Main panel – upper end position



**Fig.5.** Main panel – lower end position

### 3. OPERATION

The "time to off pump" shows actual delay time to stop the pump in Barrel mode after the actuator reach the lower end position. This time parameter can be changed in settings menu (point 3.4.4).

#### 3.4.3. Pump speed panel



To navigate to this panel use arrow up button: (panel available only from main panel). In this panel user can check actual pump speed in [rpm] units:



Fig.6. Pump speed panel



To back to main panel use arrow down button: or information button: ;

**NOTE:**

Pump speed will be only displayed if unit is equipped with a frequency inverter and only during pump is working. Otherwise displayed pump speed will be equal to 0 rpm.

#### 3.4.4. Settings



To navigate to this panel use information button: (panel available only from main panel).

**a) Panel: time to off pump set:**

In this panel user are able to change time delay parameter for switch off the pump in barrel mode after the actuator reach the lower end position.

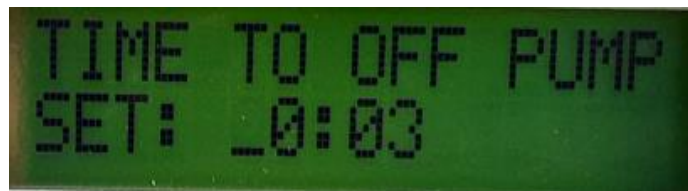





Fig.7. Time to off pump set panel

- To set time on the panel use numerical keyboard (mm:ss), If digits are indicate then it is possible to change the value;
- to confirm time selection press enter button:  ;
- back to Main panel press information button:  ;



### 3. OPERATION

To navigate to next panel (time to alarm LS) use arrow down button  (panel available only from time to off pump set).

**b) Panel: time to alarm LS set:**



**Fig.8.** Time to alarm LS set panel

- To set time on the panel use numerical keyboard (mm:ss:hh), If digits are indicate then it is possible to change the value;
- to confirm time selection press enter button: ;
- back to previous menu press arrow up button: ;
- back to Main panel press information button: ;

**NOTE:**

The set time is only relevant if the device is equipped with a dry-running level sensor, otherwise this time has no significance for the device's operating cycle.

**3.4.5. Alarms**

To navigate to this panel use arrow down button:  (panel available only from main panel).



**Fig.9.** Alarm code panel

Alarm code shows actual alarm state of the unit, the "0" states means there is no alarm states and machine is ready to work. If in any of this positions appear value equal to "1" then it means a specific alarm state.

All of the alarm states will be indicating by red alarm lamp (H1);

**Alarm code:**

SYMBOL	DESCRIPTION
00000	Non of alarms is active;
10000	Emergency Stop (ESTOP – S1) is pressed;

### 3. OPERATION

---

<b>01000</b>	Pressure sensor – high pressure detected;
<b>00100</b>	Level sensor – Dry run detected;
<b>00010</b>	PTC alarm detected;
<b>00001</b>	Motor breaker alarm detected;

It may happen that more than one value is equal 1, in that case it only means that many alarm state was appear in the same time.

Example:

alarm state: **11001** means:

- E-STOP button is pressed;
- High pressure was detected;
- Motor breaker alarm was detected;

**NOTE:**

- Once when alarm was detected the alarm states will be visible until user reset alarm states. To reset the alarm states press RESET button (S2).
- Before resetting the alarm, check the error code on the electronic controller display panel make sure that the problem source is removed.
- If unit is no equipped with Pressure or/and Level sensor then the alarms from them should never appear, it should show "0" value, in other case check the connection on the terminal block, the jumper should be connected between 25 and 28 terminal (for Pressure sensor), and between 29 and 32 (for Level sensor).

## 3. OPERATION

### 3.5. Pneumatic Control

The parameters of pneumatic system has been adjusted to the application for maximum efficiency and safety level. However the optimal settings may be different depending on the pneumatic supply source.

#### 3.5.1. Air Filter-Regulator

Recommended Setting :

1. 6 bar on the Filter-regulator
2. 2 bar on the middle regulator (Areation of the barrel)
3. 0,5 bar on the left regulator (pressure force of the scraping lid during emptying the barrel) – It is allowed to regulate the pressure setting in the range from 0 to 0,6 bar.

The air pressure can be adjusted by unlocking and rotating the knob. The air setting should be lower than pressure available form source.

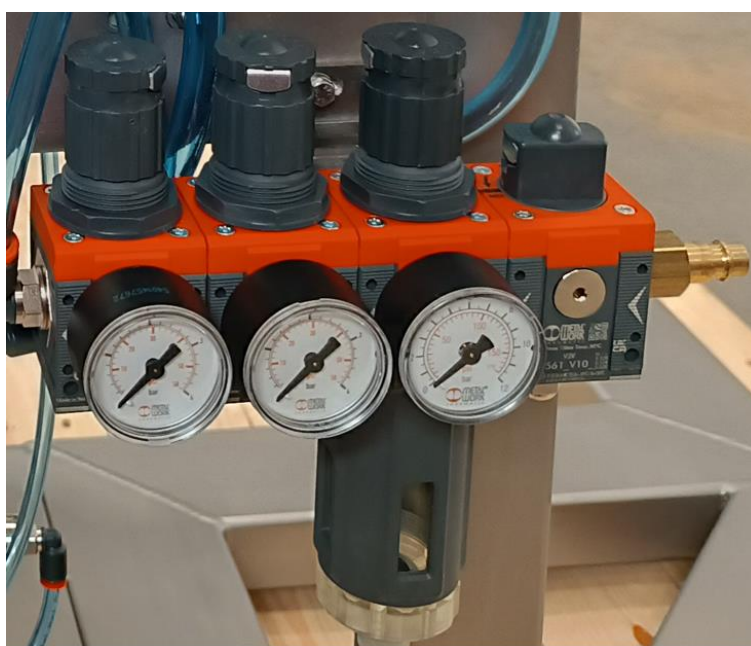

#### 3.5.2. Max Piston Position sensor

The upper max position can be adjusted according to the accesory instruction (cat. No W095435).



## 3. OPERATION

---

### 3.5.3. Min. Piston Position sensor

The lower minimal position can be adjusted according to the accessory instruction (cat. No W095435).



### 3.5.4. Lifting up speed

The speed of lifting up can be adjusted by the screw of relief valve (cat. No 9011009C).



### 3.5.5. Lowering down speed

The speed of lowering down can be adjusted by the screw of relief valve (cat. No 9011009C).

### 3. OPERATION

---

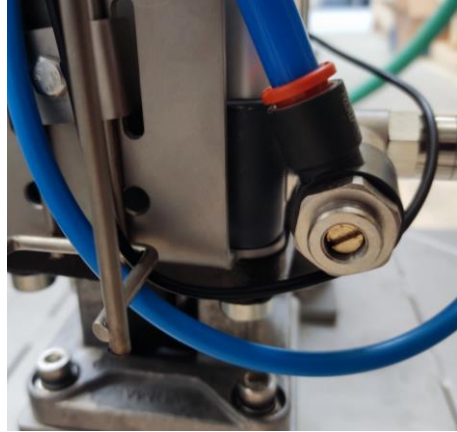

## 4. MAINTENANCE

---

### 4. MAINTENANCE

#### 4.1. Operating conditions

To ensure long-term and trouble-free operation of the unit, follow the recommendations of this manual. Pay attention to the correct way of use and appropriate working conditions. Failure to follow these rules may cause damage to the unit.

The pumping system should be kept clean, which will allow you to easily notice even minor damage, which, if unnoticed, can cause later failures and longer downtime, or be a danger to the operator.

To improve safety, Tapflo allows the user to install additional guards. Possible guards should be attached to the unit frame, taking its load bearing capacity into account.

The sound pressure level at the workstation of the pumping system at nominal operation should not exceed 85 dB. Despite this, it is recommended to use appropriately selected individual noise protection measures.

#### 4.2. General guidelines

Operation requires:

- Ad hoc inspection,
- Periodic inspections.

#### 4.3. Inspection and periodical checks

In order to maintain the constant technical efficiency of the pumping system, it is necessary to perform periodic inspections and remove any defects noted. Repairs should be carried out only by authorized and properly trained personnel.

All components should be inspected and maintained at least once a year in accordance with manufacturers' guidelines.

During the inspection, pay particular attention to:

- pipeline connections, checking them for leaks,
- the pump, checking the condition and level of lubricating oil.
- Actuator and lifting mechanism, checking the lubrication and tightness of the nuts, rolls and sideslips.



When performing maintenance work, remember to disconnect power from the unit.



## 4. MAINTENANCE

### 4.4. Operation of individual equipment

Strictly follow the instructions in the manuals of the various components of the system. All components should be inspected and maintained at least once a year in accordance with manufacturers' guidelines.

### 4.5. Shutting down and flushing the unit

Before shutting down the unit for an extended period, flush it with clean water to remove any residual medium.

### 4.6. Troubleshooting

Possible fault	Possible solution
<b>The unit does not pump</b>	<ul style="list-style-type: none"> <li>➤ The unit is not connected to the power supply</li> <li>➤ The unit is not switched on.</li> <li>➤ Inverter setting is insufficient.</li> <li>➤ The pressure in the installation is too high.</li> </ul>
<b>The unit does not lift the pump</b>	<ul style="list-style-type: none"> <li>➤ The unit is not connected to the air supply</li> <li>➤ Air supply pressure is too low</li> <li>➤ The unit is not connected to the power supply</li> <li>➤ One of the air tubing is disconnected or there is the leakage</li> <li>➤ Electrovalve is damaged</li> </ul>

### 4.7. Identification of hazards arising during use of the dosing unit

Risks associated with the use of pump systems may occur during the following operating phases:

- a) Transport,
- b) Installation and disassembly at the workplace,
- c) Workplace maintenance,
- d) Operation.

Type of threat	Pump system status			
	a)	b)	c)	d)
Leakage of the pumped medium.	x	x	x	x
High pressure of the pumped medium.		x	x	x
Electrical shock, contact with electrically live equipment parts.		x	x	x
Mechanical failures, or malfunction of assemblies.				x
Burn from hot element, hazardous medium.	x	x	x	x
Excessive exposure to noise.				x
Inadequate lighting.	x	x	x	x
Fire.				x

## 5. DISPOSAL

---

### 5. DISPOSAL

#### 5.1. Disposal after expiration of the expected lifetime

The metallic components like aluminium, stainless steel and carbon steel can be recycled. Plastic parts are not recyclable and must be disposed of as residual waste. The pump must be disposed of properly, according to local regulations. It should be noted that potentially dangerous fluid residues may remain in the pump and can create a hazard to the operator or the environment, therefore the pump has to thoroughly cleaned before disposal.

#### 5.2. Waste of electrical and electronic equipment (WEEE) directive

Electrical and electronic equipment (EEE) with the WEEE label listed in Annex IV of the WEEE Directive must not be disposed of at the end of its life cycle as unsorted municipal waste. All waste collection frameworks should be used, including returns, recycling, recovery of WEEE to minimize the potential impact of this equipment on the environment and human health due to the presence of hazardous substances.

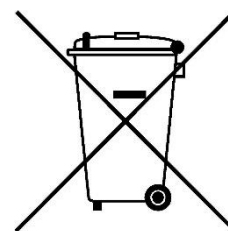

The WEEE marking applies only to countries within the European Union (EU) and Norway. Appliances are labelled in accordance with European Directive 2002/96/EC. Contact your local waste recovery agency for a designated collection facility in your area.

## 6. SPARE PARTS

---

### 6. SPARE PARTS

#### 6.1. Spare parts description

Replacement parts for the unit include:

- pump gear oil.
- Scraping lid seal
- Pump stator
- Sideslips

Mechanical parts can be replaced preventively at certain intervals or simply wait until they wear out as it is not possible to determine their service life. Keep in mind that any wear and tear may have consequences for the operation of the unit. The decision is up to the user.

For information on the pump gear oil change interval, please refer to the pump manual - Appendix 1.

#### 6.2. How to order parts

When ordering spare parts for Tapflo units, please let us know what the model number and serial number from the pump's name plate is, then just indicate the part numbers from the spare parts list and quantity of each item.

## **7. APPENDICES**

---

- 7. APPENDICES**
- 7.1. Manual - pump - Jessberger**
- 7.2. GA assembly drawing**
- 7.3. Electrical documentation**

# 8. WARRANTY

---

## 8. WARRANTY

### 8.1. Returning parts

When returning parts to Tapflo please follow this procedure:

- Consult Tapflo for shipping instructions.
- Cleanse or neutralize and rinse the part/pump. Make sure the part/pump is completely empty from liquid.
- Pack the return articles carefully to prevent any damage during transportation.

***Goods will not be accepted unless the above procedure has been complied with.***

### 8.2. Warranty

Tapflo warrants products under conditions as stated below for a period of not more than 12 months from installation and not more than 18 months from date of manufacturing.

1. The following terms and conditions apply to the sale of machinery, components and related services and products, of Tapflo (hereinafter "the products").
2. Tapflo (the manufacturer) warrants that:
  - a. its products are free of defects in material, design and workmanship at the time of original purchase;
  - b. its products will function in accordance with Tapflo operative manuals; Tapflo does not guarantee that the product will meet the precise needs of the Customer except for those purposes set out in any invitation to render documents or other documents specifically made available to Tapflo before entering into this agreement;
  - c. high-quality materials are used in the construction of the mixers and that machining and assembly are carried out to the highest standards.

Except as expressly stated above, Tapflo makes no warranties, express or implied, concerning the products, including all warranties of fitness for a particular purpose.

3. This warranty shall not be applicable in circumstances other than defects in material, design and workmanship. In particular warranty shall not cover the following:
  - a. Periodic checks, maintenance, repair and replacement of parts due to normal wear and tear;
  - b. Damage to the product resulting from:
    - b.1. Tampering with, abuse or misuse, including but not limited to failure to use the product for its normal purposes as stated at the time of purchase or in accordance with Tapflo instructions for use and maintenance of the product, or the installation or improper ventilation or use of the product in a manner inconsistent with the technical or safety standard in force;
    - b.2. Repairs performed by non-skilled personnel or use of non-original Tapflo parts;
    - b.3. Accidents or any cause beyond the control of Tapflo, including but not limited to lightning, water, fire, earthquake and public disturbances etc.;

## 8. WARRANTY

---

4. The warranty shall cover the replacement or repairing of any parts, which is documented faulty due to construction or assembling, with new or repaired parts free of charges delivered by Tapflo. Parts subjected to normal tear and wear shall not be covered by the warranty. Tapflo shall decide as to whether the defective or faulty part shall be replaced or repaired.
5. The warranty of the products shall be valid for a period in accordance with the current law from the date of delivery, under the condition that notice of the alleged defect to the products or parts thereof be given to Tapflo in written within the mandatory term of 8 days from the discovery. Repair or replacement under the terms of this warranty shall not give a right to an extension to or a new commencement of the period of warranty.
6. Repair or replacement under the terms of this warranty shall not give a right to an extension to, or a new commencement of, the period of warranty. Repair or replacement under the terms of this warranty may be fulfilled with functionally equivalent reconditioned units. Tapflo qualified personnel shall be solely entitled to carry out repair or replacement of faulty parts after careful examination of the mixer. Replaced faulty parts or components will become the property of Tapflo.
7. Installation, including electric and other connections to utility mains according to Tapflo drawings, is for the cost and responsibility of the customer unless otherwise agreed in writing.
8. Tapflo will not be liable on any claim, whether in contract, tort, or otherwise, for any indirect, special, incidental or consequential damages caused to the customer or to third parties, including loss of profits arising by any possible infringement of par. 3 above or by the customer or third parties being in the impossibility of using the products.

## 8. WARRANTY

---

THIS PAGE INTENTIONALLY LEFT BLANK

## Sweden

Filaregatan 4 | S-442 34 Kungälv

Tel: +46 303 63390

Fax: +46 303 19916

E-mail addresses:

Commercial questions: [sales@tapflo.com](mailto:sales@tapflo.com)

Orders: [order@tapflo.com](mailto:order@tapflo.com)

Tech support: [support@tapflo.com](mailto:support@tapflo.com)

## Tapflo products and services are available worldwide.

Tapflo is represented by own Tapflo Group Companies and carefully selected distributors assuring highest Tapflo service quality for our customers' convenience.

AUSTRALIA | AUSTRIA | AZERBAIJAN | BAHRAIN | BELGIUM | BOSNIA & HERZEGOVINA | BRAZIL | BULGARIA | CANADA | CHILE | CHINA | COLOMBIA | CROATIA | CZECH REPUBLIC | DENMARK | ECUADOR | EGYPT | ESTONIA | FINLAND | FRANCE | GEORGIA | GERMANY | GREECE | HONG-KONG | HUNGARY | ICELAND | INDIA | INDONESIA | IRELAND | ISRAEL | ITALY | JAPAN | JORDAN | KAZAKHSTAN | KUWAIT | LATVIA | LIBYA | LITHUANIA | MACEDONIA | MALAYSIA | MEXICO | MONTENEGRO | MOROCCO | NETHERLANDS | NEW ZEALAND | NORWAY | POLAND | PORTUGAL | PHILIPPINES | QATAR | ROMANIA | SAUDI ARABIA | SERBIA | SINGAPORE | SLOVAKIA | SLOVENIA | SOUTH AFRICA | SOUTH KOREA | SPAIN | SWEDEN | SWITZERLAND | TAIWAN | THAILAND | TURKEY | UKRAINE | UNITED ARAB EMIRATES | UNITED KINGDOM | USA | UZBEKISTAN | VIETNAM

## Tapflo Group Companies

### Australia

Tapflo Oceania (Pty) Ltd.  
Tel: +61 1800303633  
[sales@tapflo.com.au](mailto:sales@tapflo.com.au)

### Austria

Tapflo GmbH  
Tel: +43 73227292910  
[sales@tapflo.at](mailto:sales@tapflo.at)

### Baltic States

Tapflo SIA  
Tel: +371 67472205  
[sales@tapflo.lv](mailto:sales@tapflo.lv)

### Belgium

Tapflo Benelux B.V.  
Tel: +31 (0)850074300  
[info@tapflo.nl](mailto:info@tapflo.nl)

### Bulgaria

Tapflo EOOD  
Tel: +359 (0)29741854  
[office@tapflo.bg](mailto:office@tapflo.bg)

### Canada

Tapflo Canada  
Tel: +1 5148135754  
[canada@tapflo.com](mailto:canada@tapflo.com)

### China

Tapflo (Wuxi) Pumps Co. Ltd.  
Tel: +86 51082417072  
[sales@tapflo.cn](mailto:sales@tapflo.cn)

### Croatia

Tapflo d.o.o.  
Tel: +385 914884666  
[sales@tapflo.hr](mailto:sales@tapflo.hr)

### Czech Republic

Tapflo s.r.o.  
Tel: +420 513033924  
[tapflo@tapflo.cz](mailto:tapflo@tapflo.cz)

### Denmark

Tapflo Danmark ApS  
Tel: +45 36454600  
[info@tapflo.dk](mailto:info@tapflo.dk)

### France

Sarl Tapflo France  
Tel: +33 134788240  
[info@tapflo.fr](mailto:info@tapflo.fr)

### Hungary

Tapflo Kft.  
Tel: +36 30148 8551  
[office@tapflo.hu](mailto:office@tapflo.hu)

### India

Tapflo Fluid Handling India Pvt Ltd.  
Tel: +91 2065000215  
[ac@tapflo.in](mailto:ac@tapflo.in)

### Ireland

Tapflo Ireland Ltd.  
Tel: +353 12011911  
[info@tapflo.ie](mailto:info@tapflo.ie)

### Italy

Tapflo Italia S.r.l.  
Tel: +39 0362306528  
[info@tapfloitalia.com](mailto:info@tapfloitalia.com)

### Japan

Tapflo Japan K.K.  
Tel: +81 362403510  
[tapflojp@tapflo.co.jp](mailto:tapflojp@tapflo.co.jp)

### Kazakhstan

Tapflo LLP  
Tel: +7 7273278347  
[sales@tapflo.kz](mailto:sales@tapflo.kz)

### Netherlands

Tapflo Benelux B.V.  
Tel: +31 (0)850074300  
[info@tapflo.nl](mailto:info@tapflo.nl)

### Poland

Tapflo Sp. z o.o.  
Tel: +48 585304212  
[info@tapflo.pl](mailto:info@tapflo.pl)

### Romania

S.C. Tapflo Rom. S.r.l.  
Tel: +40 213451255  
[sales@tapflo.ro](mailto:sales@tapflo.ro)

### Serbia

Tapflo d.o.o.  
Tel: +381 21445808  
[sales@tapflo.rs](mailto:sales@tapflo.rs)

### Slovakia

Tapflo s.r.o.  
Tel: +421 911137883  
[tapflo@tapflo.sk](mailto:tapflo@tapflo.sk)

### Slovenia

Tapflo d.o.o.  
Tel: +386 68613474  
[sales@tapflo.hr](mailto:sales@tapflo.hr)

### Spain

Tapflo Ibérica S.L.  
Tel: +34 918093182  
[avives@tapfloiberica.es](mailto:avives@tapfloiberica.es)

### South Africa

Tapflo (Pty) Ltd.  
Tel: +27 317015255  
[sales@tapflo.co.za](mailto:sales@tapflo.co.za)

### Sweden

Tapflo AB  
Tel: +46 (0)30314050  
[info@tapflo.com](mailto:info@tapflo.com)

### Turkey

Tapflo Makina Ltd.  
Tel: +90 2164673311  
[sales@tapflo.com.tr](mailto:sales@tapflo.com.tr)

### Ukraine

Tapflo LLC  
Tel: +380 442226844  
[sales@tapflo.ua](mailto:sales@tapflo.ua)

### Uzbekistan

Tapflo Uzbekistan  
Tel: +998 712370940  
[sales@tapflo.uz](mailto:sales@tapflo.uz)

### United Kingdom

Tapflo (UK) Ltd.  
Tel: +44 2380252325  
[sales@tapflo pumps.co.uk](mailto:sales@tapflo pumps.co.uk)



If your country is not listed  
please visit  
[www.tapflo.com/en/contact](http://www.tapflo.com/en/contact)