

Use and Maintenance Manual

TRANSLATION OF THE ORIGINAL INSTRUCTIONS

EN

MACHINERY

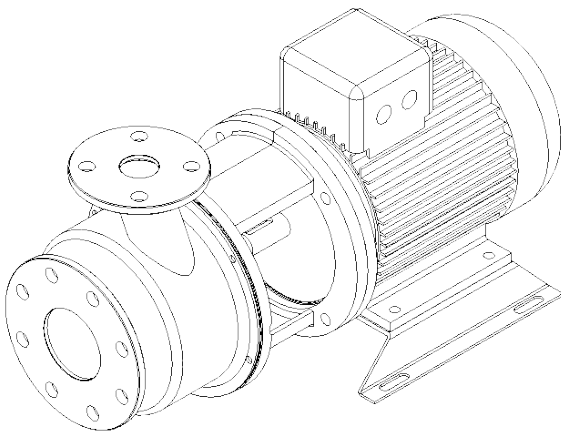

MACHINERY

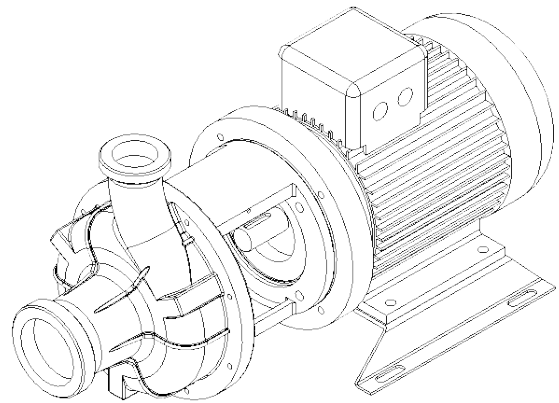

MODEL	<ul style="list-style-type: none">RSM - RSA - HDM - HDA - HGM - HGA
VERSION	<ul style="list-style-type: none">CLOSE COUPLED PUMP
EDITION	<ul style="list-style-type: none">06/2020



SALVATORE ROBUSCHI & C. S.r.l.

Via Segrè 11/a - 43122 Parma - Italy  

tel. +39 0521 606285

Fax +39 0521 606278

www.salvatorerobuschi.com

sr@salvatorerobuschi.com

FOREWORD

All rights reserved. No part of this instruction manual can be reproduced or transmitted by any electronic or mechanical means, including photocopies, recordings or any other storage and data retrieval system, for any purpose other than the exclusive personal use of the purchaser, without the express written consent of Salvatore Robuschi & C. S.r.l.

Salvatore Robuschi & C. S.r.l. shall by no means be held responsible for the consequences resulting from the user's misuse of the system.

EDITOR'S NOTE

This documentation is expressly addressed to technicians. Therefore, information that can be easily retrieved by reading these texts and analysing the drawings may not be explained further.

The Editor shall by no means be held responsible for the information and data referred to in this manual: all the information included in it is supplied, controlled and approved on the premises after Salvatore Robuschi & C. S.r.l./Representative's verification. Salvatore Robuschi & C. S.r.l. is in no way responsible for any consequences as a result of incorrect operations carried out by the user.

GENERAL REMARKS

Any operational and maintenance instructions, as well as the recommendations described herein, shall be complied with.

To achieve the best results Salvatore Robuschi & C. S.r.l. recommends performing regular cleaning and maintenance operations to keep the plant in the best conditions. It is particularly important to train personnel in charge of the line, with regard to its use, maintenance and in compliance with the operating procedures and all the safety standards provided in this manual. In any case, note that the writing company is always available for any clarifications or additional information.

REVISIONS INDEX

CODE	REV.	DATE	No. OF LAST PAGE	PUBLICATION NOTES
T-2351	00	03/2020	50	-

THE MANUAL IS AVAILABLE IN DIGITAL FORMAT IN SEVERAL LANGUAGES, ON THE WEBSITE "<http://www.salvatorerobuschi.com>".

COPYRIGHT

© 2020 Salvatore Robuschi & C. S.r.l.

1. SOMMARIO

1. IDENTIFICATION.....	6
1.1. MANUFACTURER IDENTIFICATION.....	6
1.2. IDENTIFICATION PLATE.....	6
1.3. PUMP IDENTIFICATION CODE.....	7
1.4. GROUP PARTITION.....	8
2. GENERAL INFORMATION.....	9
2.1. ADDRESSEES.....	9
2.2. SUPPLY AND PRESERVATION.....	9
2.3. USE AND KNOWLEDGE OF THE MANUAL.....	9
2.4. SYMBOLS USED IN THE MANUAL.....	9
2.5. DIRECTIVES OF REFERENCE.....	10
2.6. WARRANTY.....	10
2.7. TESTING.....	10
2.8. DOCUMENTS SUPPLIED.....	10
2.9. LIST OF DOCUMENTS AVAILABLE ONLINE.....	10
3. SAFETY RULES.....	11
3.1. PERSONAL PROTECTIVE EQUIPMENT.....	11
3.2. RESIDUAL RISKS.....	12
3.3. SAFETY REQUIREMENTS.....	13
3.3.1. SAFETY INFORMATION FOR OPERATOR / USER (EXCLUDING INSTALLATION, MAINTENANCE AND DISASSEMBLY OPERATIONS) 13	
3.4. NOISE.....	14
3.5. VIBRATIONS.....	14
4. RECEIPT, HANDLING AND STORAGE.....	16
4.1. PACKAGING.....	16
4.1.1. REMOVAL OF PACKAGING AND HANDLING.....	16
4.2. CHECKING ON RECEIPT.....	16
4.3. TRANSPORT AND HANDLING.....	16
4.3.1. TRANSPORTATION OPERATIONS.....	16
4.4. STORAGE.....	19



5. FEATURES.....	20
5.1. PERFORMANCE AND OPERATING LIMITS.....	20
5.2. PERMITTED ENVIRONMENTAL CONDITIONS.....	20
5.3. LIMITS FOR ATEX PUMPS.....	20
6. INSTALLATION	21
6.1. FOUNDATION.....	22
6.2. INSTALLATION AND FIXING.....	22
6.3. PIPES.....	22
6.3.1. MAXIMUM PERMISSIBLE LOADS.....	22
6.3.2. FIXING OF PIPES.....	24
6.3.3. SUCTION AND DISCHARGE PIPES.....	24
6.3.4. FILTERS.....	26
6.3.5. VENT.....	27
6.3.6. DRAIN.....	27
6.3.7. CONTROL INSTRUMENTS.....	27
6.3.8. AUXILIARY PIPING SEALS AND HEATING / COOLING CHAMBERS.....	28
6.4. MECHANICAL CHECKS AND PRELIMINARY CHECKS.....	28
6.4.1. COUPLING GUARD.....	28
6.4.2. ROTATION.....	28
6.5. INSTALLATION OF PROTECTIONS.....	28
6.6. ELECTRICAL CONNECTION.....	29
7. USE.....	30
7.1. PRELIMINARY INSPECTIONS.....	30
7.2. START-UP.....	30
7.3. PIPING FILLING.....	31
7.3.1. PRIMED CONDITION (POSITIVE GEODETIC SUCTION HEAD).....	31
7.3.2. NON-PRIMED CONDITION (NEGATIVE GEODETIC SUCTION HEAD).....	31
7.4. PACKING GLAND PRELIMINARY REGULATION.....	31
7.5. HEATING / COOLING / SEALS SUPPLY.....	31
7.6. ROTATION DIRECTION TEST.....	32
7.7. PUMP START.....	32
7.7.1. CHECKS AFTER START-UP.....	32
7.7.2. ADJUSTMENT OF PACKING GLAND AFTER START-UP.....	33
7.8. STOP.....	33
7.9. EXTENDED STOPS.....	33



8. CHECKS AND MAINTENANCE.....	34
8.1. SAFETY INFORMATION FOR CHECKS AND MAINTENANCE	34
8.2. PERIODIC CHECKS.....	35
8.2.1. LUBRICATION	35
8.2.2. FLUSHING	35
8.2.3. PERFORMANCE.....	35
8.2.4. MOTOR	35
8.2.5. PROTECTIONS.....	35
8.2.6. SEALS.....	36
8.2.7. INSTRUMENTATION AND AUXILIARY DEVICES.....	36
9. DISASSEMBLY AND REASSEMBLY.....	37
9.1. SAFETY INFORMATION FOR DISASSEMBLY AND REASSEMBLY	37
9.2. PRELIMINARY OPERATIONS	38
9.2.1. DRAIN	38
9.2.2. DISCONNECTION.....	38
9.2.3. FINAL RECLAMATION	38
9.3. INSTRUCTIONS FOR DISASSEMBLY AND REASSEMBLY OF THE PUMP	38
10. SPARE PARTS	39
10.1. SPARE PARTS REQUEST, COMMISSIONING AND START-UP	39
10.2. SPARE PARTS AND SPARE PARTS SET FOR THE FIRST TWO YEARS OF USE (DIN 24296)	39
10.3. START UP SPARE PARTS AND SPARE PARTS SET	40
11. SHIPPING TO SUPPLIER.....	41
12. END OF LIFE AND DISPOSAL.....	42
13. APPENDIX A – AUXILIARY CONNECTIONS AND SEAL FLUSHING.....	42
13.1. SEAL EXECUTION IDENTIFICATION	42
13.2. PLAN IDENTIFICATION.....	42
13.3. NAME.....	42
13.4. AUXILIARY CONNECTIONS AND SEAL FLUSHING	43
13.5. SALVATORE ROBUSCHI & C. S.R.L. TANK DIAGRAM	47
14. APPENDIX B.....	48



1. IDENTIFICATION

1.1. MANUFACTURER IDENTIFICATION

Manufacturer	SALVATORE ROBUSCHI & C. S.R.L. Via Segrè 11/a - 43122 Parma - Italy tel. +39 0521 606285 Fax +39 0521 606278 www.salvatorerobuschi.com sr@salvatorerobuschi.com
---------------------	---

1.2. IDENTIFICATION PLATE

POS.	DESCRIPTION
1	MANUFACTURER'S LOGO
2	PUMP IDENTIFICATION CODE (See Paragraph "PUMP IDENTIFICATION CODE")
3	SERIAL NUMBER
4	PUMP DUTY FLOW RATE (IF SUPPLIED BY THE CUSTOMER)
5	'Ex' MARKING (OPTIONAL – ONLY FOR PUMPS SUITABLE FOR OPERATING IN EXPLOSION HAZARD ZONES)
6	'CE' MARKING
7	YEAR OF MANUFACTURE
8	PUMP DUTY HEAD (IF SUPPLIED BY THE CUSTOMER)
9	CUSTOMER IDENTIFICATION ITEM (IF SUPPLIED BY THE CUSTOMER)
10	'ATEX' IDENTIFICATION MARKING (OPTIONAL – ONLY FOR PUMPS SUITABLE FOR OPERATING IN EXPOSION HAZARD ZONES)
11	SPACE FOR ADDITIONAL NORMATIVE INFORMATION UPON CUSTOMERS' REQUEST

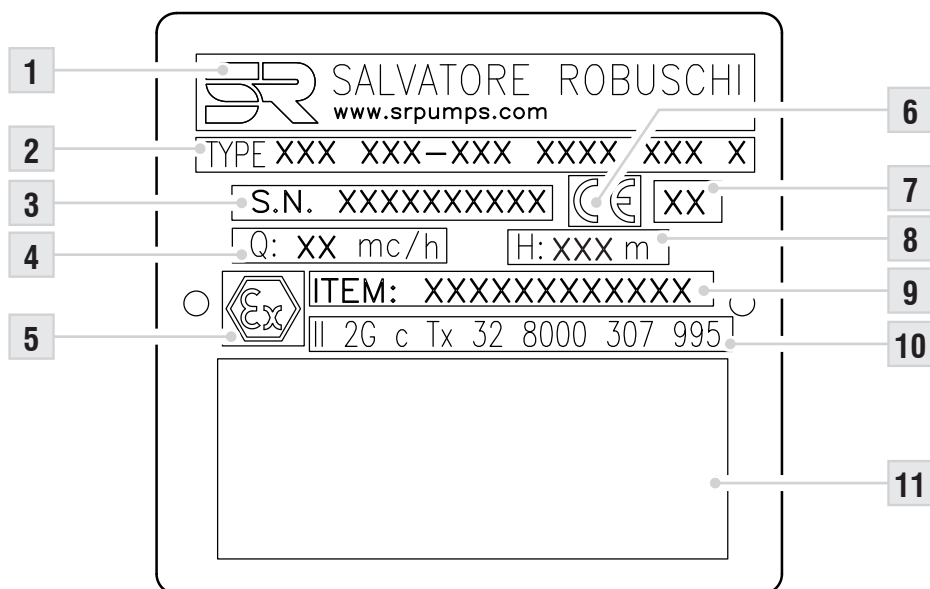

CAUTION!

IT IS STRICTLY PROHIBITED to remove the CE identification plate and/or replace it with other plates.

Should the plate be damaged, detached or removed for accidental reasons, the customer must inform the Manufacturer.



1.3. PUMP IDENTIFICATION CODE

There is an identification code on every pump.

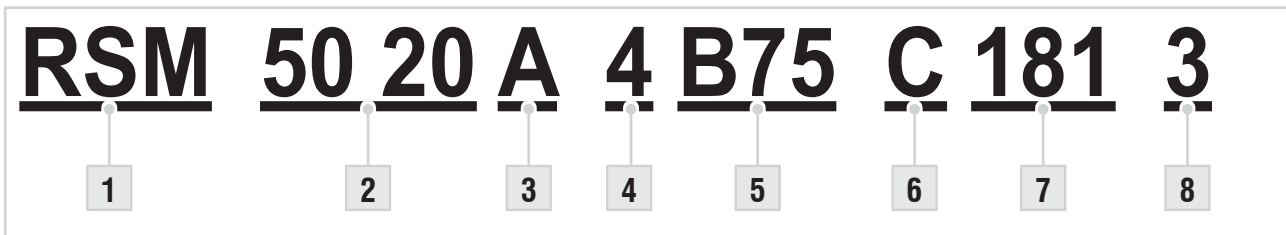

Below is the diagram of the coding applied:

POS.	DESCRIPTION																																																																								
1	PUMP MODEL <ul style="list-style-type: none"> RSM / RSA – Close Coupled Pump with flange / with DIN connections – Vortex Impeller HDM / HDA – Close Coupled Pump with flange / with DIN connections – Closed Impeller HGM / HGA – Close Coupled Pump with flange / with DIN connections – Open Impeller 																																																																								
2	PUMP SIZE																																																																								
3	IMPELLER REDUCTION <ul style="list-style-type: none"> “A” maximum diameter “B” 1° reduction “C” 2° reduction “AR” intermediate reduction (between A and B) 																																																																								
4	MOTOR POLARITY <ul style="list-style-type: none"> 2 = 2-pole electric motor 4 = 4-pole electric motor 6 = 6-pole electric motor 8 = 8-pole electric motor 																																																																								
5	ELECTRICAL MOTOR POWER <ul style="list-style-type: none"> A - 0.25 → 0,75 kW <table border="1"> <thead> <tr> <th>KW</th> <th>0.25</th> <th>0.37</th> <th>0.55</th> <th>0.75</th> </tr> </thead> <tbody> <tr> <td>Code</td> <td>A25</td> <td>A37</td> <td>A55</td> <td>A75</td> </tr> </tbody> </table> B - 1.1 → 9.2 kW <table border="1"> <thead> <tr> <th>KW</th> <th>1.1</th> <th>1.5</th> <th>2.2</th> <th>3.0</th> <th>4.0</th> <th>5.5</th> <th>7.5</th> <th>9.2</th> </tr> </thead> <tbody> <tr> <td>Code</td> <td>B11</td> <td>B15</td> <td>B22</td> <td>B30</td> <td>B40</td> <td>B55</td> <td>B75</td> <td>B92</td> </tr> </tbody> </table> C - 11 → 90 kW <table border="1"> <thead> <tr> <th>KW</th> <th>11</th> <th>15</th> <th>18.5</th> <th>22</th> <th>30</th> <th>37</th> <th>45</th> <th>55</th> <th>75</th> <th>90</th> </tr> </thead> <tbody> <tr> <td>Code</td> <td>C11</td> <td>C15</td> <td>C18</td> <td>C22</td> <td>C30</td> <td>C37</td> <td>C45</td> <td>C55</td> <td>C75</td> <td>C90</td> </tr> </tbody> </table> D - 110 → 400 kW <table border="1"> <thead> <tr> <th>KW</th> <th>110</th> <th>132</th> <th>160</th> <th>200</th> <th>225</th> <th>250</th> <th>280</th> <th>315</th> <th>355</th> <th>400</th> </tr> </thead> <tbody> <tr> <td>Code</td> <td>D11</td> <td>D13</td> <td>D16</td> <td>D20</td> <td>D22</td> <td>D25</td> <td>D28</td> <td>D31</td> <td>D35</td> <td>D40</td> </tr> </tbody> </table> 	KW	0.25	0.37	0.55	0.75	Code	A25	A37	A55	A75	KW	1.1	1.5	2.2	3.0	4.0	5.5	7.5	9.2	Code	B11	B15	B22	B30	B40	B55	B75	B92	KW	11	15	18.5	22	30	37	45	55	75	90	Code	C11	C15	C18	C22	C30	C37	C45	C55	C75	C90	KW	110	132	160	200	225	250	280	315	355	400	Code	D11	D13	D16	D20	D22	D25	D28	D31	D35	D40
KW	0.25	0.37	0.55	0.75																																																																					
Code	A25	A37	A55	A75																																																																					
KW	1.1	1.5	2.2	3.0	4.0	5.5	7.5	9.2																																																																	
Code	B11	B15	B22	B30	B40	B55	B75	B92																																																																	
KW	11	15	18.5	22	30	37	45	55	75	90																																																															
Code	C11	C15	C18	C22	C30	C37	C45	C55	C75	C90																																																															
KW	110	132	160	200	225	250	280	315	355	400																																																															
Code	D11	D13	D16	D20	D22	D25	D28	D31	D35	D40																																																															



POS.	DESCRIPTION
6	SEALING SYSTEMS <ul style="list-style-type: none"> B Packing ring without hydraulic barrier C Back-to-back double mechanical seal E Single mechanical seal for external flushing H If present before the letter identifying the sealing system, the seal is provided with a heating/cooling chamber (Eg. HB = Heated/cooled packing ring) L Double mechanical seal in "tandem" configuration M Single mechanical seal S Packing ring with hydraulic barrier
7	MAIN MECHANICAL SEAL CODE <ul style="list-style-type: none"> For versions "B" and "S" = 000
8	PUMP'S MAIN MATERIALS CODE <ul style="list-style-type: none"> Refer to the table below.

DESCRIPTION	PUMP MATERIAL CODE	
	3	8
CASING	CF8M (AISI 316)	SAF2507
CASING COVER	CF8M (AISI 316)	SAF2507
IMPELLER	CF8M (AISI 316)	SAF2507
CLOSE COUPLED PUMP SHAFT	AISI 316L	AISI 316L ^(B)
SUPPORT FOOT	S 235 JR	S 235 JR
LANTERN	GJL200/GJL250/ S235JR	GJL200/GJL250/ S235JR
SINGLE SEAL COVER	AISI 316L	SAF2507
DOUBLE SEAL COVER	AISI 316L	AISI 316L
IMPELLER HUB	AISI 316L	TI
WEAR PLATE ^(C)	AISI 316L	SAF2507

- (B) NOT IN CONTACT WITH THE PUMPED LIQUID
- (C) ONLY FOR "HG" SERIES

1.4. GROUP PARTITION

Below group partition table:

GROUP	MODEL
1	• RS : 20-08
2	• RS : 25-12, 32-12, 40-12
3	• RS : 32-16, 40-16, 50-16, 65-16
4	• RS : 32-20, 40-20, 50-20, 65-20

GROUP	MODEL
1	• HD - HG : 25-16, 25-19, 32-16, 40-16, 50-16
2	• HD - HG : 32-20, 40-20, 50-20, 65-16
3	• HD - HG : 80-16, 65-20, 80-20



2. GENERAL INFORMATION

2.1. ADDRESSEES

This manual is destined to operators in charge of dealing with the pump in all the stages of its technical life.

This manual provides instructions and information valid only for the pumps to which it is attached and does NOT constitute an instruction manual for the system in which the pumps are inserted.

It also contains the subjects regarding the proper use of the pump, in order to maintain the functional and qualitative features of the machine unaltered over time. All information and warnings for proper safe use are also reported.

The manual, like the EC conformity certificate, is an integral part of the pump and must always accompany it in every displacement or property transfer. The user must keep this documentation intact and make it available for consultation during the entire lifetime of the pump.

2.2. SUPPLY AND PRESERVATION

The manual is provided in **printed** format.

Keep this manual with the pump so that it can be easily consulted by the operator.

The manual is an integral part for the purpose of safety, therefore:

- it must be kept intact (in all its parts). Should this manual get damaged or spoiled, request a copy immediately.
- It must accompany the pump until its demolition (even if moved, sold, leased, rented, etc.);
- the attached manuals are a part of this documentation and the same recommendations/prescriptions contained in this manual apply to them.
- For pumps compliant with directive 2014/34/EU (ATEX), an addendum is provided together with this manual, which is to be considered an integral part of the manual itself.

Salvatore Robuschi & C. S.r.l. shall not be held liable for improper use of the pump and/or damages resulting from operations not indicated in the technical documents.

2.3. USE AND KNOWLEDGE OF THE MANUAL

The personnel involved must be qualified for the installation, control and maintenance of the machine to which this manual refers. The latter must be read and understood in all its points, both by the personnel manager and by the operators who will carry out the work before installation and commissioning.

The manual must always be available for consultation.



IMPORTANT!



This manual is supplied with the pump, guaranteeing user guidelines for the correct installation, routine maintenance and disposal of the machine.

It is mandatory for the user to read the manual in all its points before performing any type of work on the pump. Work must always be carried out in total safety by qualified personnel who are familiar with the rules below.

2.4. SYMBOLS USED IN THE MANUAL

Graphic symbols have been used throughout this manual to facilitate comprehension and point out the different risk levels that may be incurred during operation of the machine.

Listed below are the symbols and their meanings:

SYMBOL	DEFINITION
	Symbol used to identify important warnings for the safety of the operator and/or the pump.
	Symbol used to identify particularly important information in the manual. The information also regards the safety of personnel involved in pump use.
	Symbol used to indicate a general prohibition.



2.5. DIRECTIVES OF REFERENCE

To certify the conformity of the pump with the provisions of the Directive, Salvatore Robuschi & C. S.r.l., before placing it on the market, has assessed the risks in order to verify compliance with the essential health and safety requirements provided by Directive 2006/42/EC as well as the tests and checks provided by the applied standards of reference.

Also note that the pump has been designed in accordance with the following Directives and/or Standards:

REF.	SUBJECT MATTER
2006/42/EC	MACHINERY DIRECTIVE
2011/65/EU	RoHS COMPATIBILITY DIRECTIVE
2014/30/EU	ELECTROMAGNETIC COMPATIBILITY DIRECTIVE
2014/35/EU	LOW VOLTAGE DIRECTIVE
EN 809:2009	PUMPS AND PUMP UNITS FOR LIQUIDS - COMMON SAFETY REQUIREMENTS
EN 12100:2010	SAFETY OF MACHINERY - GENERAL PRINCIPLES FOR DESIGN - RISK ASSESSMENT AND RISK REDUCTION
EN 13857:2008	SAFETY OF MACHINERY - SAFETY DISTANCES TO PREVENT HAZARD ZONES BEING REACHED BY UPPER AND LOWER LIMBS

2.6. WARRANTY

The warranty conditions are defined in the "General conditions of sale of Salvatore Robuschi & C. S.r.l." sent together with the order confirmation.

2.7. TESTING

Salvatore Robuschi & C. S.r.l. pumps are carefully tested through a control plan that includes:

- Hydrostatic test of the main hydraulic parts subjected to pressure
- Impeller balancing
- Pressure test after assembly
- Visual check before shipping.
- Tests or other documents performed upon request of the customer and in accordance with that indicated in the order confirmation.

2.8. DOCUMENTS SUPPLIED

Salvatore Robuschi & C. S.r.l. pumps are equipped with:

- CE Marking
- EC Declaration of Conformity
- Manual for installation, start-up and routine maintenance (documentation according to Machinery Directive 2006/42/EC, section 1.7.4)
- Atex Addendum (only for pumps compliant with ATEX directive 2014/34/EU)
- Test certificates if specified in the order confirmation

2.9. LIST OF DOCUMENTS AVAILABLE ONLINE

In addition to this manual, additional documents are available on our website www.salvatorerobuschi.com (www.srpumps.com), which can be consulted free of charge, such as: Performance Curves, Dimensions, Sections with nomenclature (BOM), Addendum.



3. SAFETY RULES







CAUTION!

Failure to comply with the information in this manual may cause the pump to malfunction and cause problems for which Salvatore Robuschi & C. S.r.l. is not responsible.

3.1. PERSONAL PROTECTIVE EQUIPMENT

When operating near the line for assembly and maintenance and/or adjustment operations strictly respect the main accident-prevention rules. For this purpose it will be mandatory to use the personal protective equipment (P.P.E.) required for each individual operation.

Below is the full list of Personal Protective Equipment (P.P.E.) that may be required for the different procedures:

SYMBOL	DESCRIPTION
	COMPULSORY USE OF PROTECTIVE OR INSULATING GLOVES Indicates a requirement for personnel to use protective or insulating gloves.
	COMPULSORY USE OF SAFETY FOOTWEAR This marks the requirement for staff to use work-safety footwear to protect their feet.
	COMPULSORY USE OF PROTECTIVE HELMET This marks the requirement for staff to use a protective helmet.
	COMPULSORY USE OF PROTECTIVE CLOTHING Indicates a requirement for personnel to wear the specific protective clothing.
	COMPULSORY USE OF PROTECTIVE GOGGLES This marks the requirement for staff to use protective goggles.
	OBLIGATION TO WEAR EARMUFFS AGAINST NOISE Indicates a requirement for personnel to use earmuffs or earplugs to protect hearing.

The clothing worn by individuals running the line or performing maintenance must comply with the essential safety requirements defined by Reg. EU 2016/425 and the regulations in force in the country where it is installed.



3.2. RESIDUAL RISKS

The pump was designed to guarantee the essential safety requirements for the operator.

Risk	PPE	Description and procedural information
Crushing hazard	   	Residual risk of crushing during transport, installation and cleaning operations.
Cutting hazard	  	Residual risk of cutting during installation and cleaning operations.
Entanglement hazard	  	Residual risk of entanglement during commissioning, use and cleaning operations.
Sliding or abrasion hazard	  	Residual risk of sliding, abrasion during commissioning, use and cleaning operations.
High voltage/electrocution hazard	  	Residual risk of contact with electrical surfaces during installation, commissioning and use.
High-pressure fluid injection or ejection hazard	   	Residual risk of injection or ejection of high pressure fluid during use and cleaning operations.
Danger of burning and burns	  	Residual risk of burning and burns during use and cleaning operations.
Danger of ejection of parts	   	Residual risk of ejection of parts during use.
Danger of noise level		Residual risk of high noise levels for pumps with noise levels above 85 dB(a) during use.
Danger of external effects on electrical devices		Residual risk of external effects on electrical devices. FORBIDDEN! People with pacemakers should not approach live motors.
Danger of fire and explosion	  	Residual risk of fire and explosion during use ONLY for pumps specifically for use in areas at risk of explosion.
Danger of unexpected ejection of machinery components or fluids	   	Residual risk of unexpected ejection of machinery components or fluids during use.



CAUTION!

Failure to comply with the information in this manual may cause the pump to malfunction and cause problems for which Salvatore Robuschi & C. S.r.l. is not responsible.



3.3. SAFETY REQUIREMENTS

The customer guarantees that every maintenance, inspection and installation job is carried out by qualified personnel who are fully aware of the contents of this manual.

In order to avoid damage to property or persons, it is mandatory to observe all the following requirements:

3.3.1. SAFETY INFORMATION FOR OPERATOR / USER (EXCLUDING INSTALLATION, MAINTENANCE AND DISASSEMBLY OPERATIONS)

- Pacemaker wearers are prohibited from approaching live electric motors.
- Operators and persons approaching the pump must be adequately informed about the location of the first aid stations present in the company and about the current safety and first aid requirements.
- It is good practice to know the location of the nearest fire-fighting equipment.
- Only approach the pump in the presence of qualified personnel and after having expressly received authorisation from the safety officer.
- Only approach the pump with suitable clothing, avoiding any clothing or objects that could get tangled and be dragged by the rotating parts of the pump (necklaces, pendants, ties, scarves, long loose hair ...).
- Only approach the pump with personal protective equipment suitable for the environment, the operations to be carried out and in compliance with the local regulations in force. Ear protection, helmet, goggles, gloves and safety shoes are recommended, in addition to the devices indicated by the factory procedures and by the safety officer.
- **IT IS FORBIDDEN** to remove the guards of the coupling or of the rotating shafts and any other safety protection during operation of the machine.
- Check the temperature of the pump and pipes before touching them. For temperatures below 5°C and higher than 45°C, take the necessary precautions and use adequate wear-resistant personal protective equipment.
- If the pump and piping contain dangerous or corrosive liquids, take the necessary precautions and use adequate wear-resistant personal protective equipment.
- If the pump is supposed to work with cold, warm or dangerous liquid, the necessary cautions have to be taken to prevent any possible accident.
- Ensure there is an earthing connection.
- Check the conformity of the performance with the order confirmation using the installed pressure gauges (or other instruments).
- In the event of excessive vibrations or noise, switch off the pump and check the cause before operating on the system.



3.4. NOISE

Noise levels have been measured in accordance with the requirements of UNI EN 11200 and UNI EN ISO 3746 standards.

During the operating cycles, exposure of personnel to noise is less than 85 dB unless otherwise specified on the operating curves, unless the noise generated by the curves, valves, section changes etc. present on the system is added to the pump noise.

It is mandatory to check the general operating curve of the pump in order to check the characteristic noise values, where present, before starting it up.

Once the pump and plant noise has been verified, it is the user's responsibility to apply the consequent preventive and protective measures, in compliance with the legislation of the country where the pump is installed.

Tables 1 - 2 indicate the noise values for each type of pump (series-size).

Table 4 summarises some typical noise values for three-phase electric motors; the actual noise pressure values may vary depending on the brand and model of the motor actually installed on the electric pump unit.

3.5. VIBRATIONS

The vibrations produced by the pump, depending on its method of operation, **are not dangerous** for the workers' health.



CAUTION!

An excessive vibration can only be caused by a mechanical fault that must be immediately reported and eliminated to avoid jeopardising the safety of the line and its operators.

SERIES	SIZE	NOISE (Lp) [dB(A)]	
		2 poles	4-6-8 poles
RS	20-08	< 77	< 72
	25-12	< 77	< 72
	32-12	< 77	< 72
	40-12	< 77	< 72
	32-16	< 78	< 73
	40-16	< 78	< 73
	50-16	< 78	< 73
	65-16	-	< 73
	32-20	< 78	< 73
	40-20	< 78	< 73
	50-20	-	< 73
	65-20	-	< 73

Table 1 - Noise values for RS series

SERIES	SIZE	NOISE (Lp) [dB(A)]	
		2 poles	4-6-8 poles
HD -HG	25-16	< 70	< 70
	25-19	< 70	< 70
	32-16	< 71	< 71
	40-16	< 71	< 71
	50-16	< 71	< 71
	50-20	< 71	< 71
	65-16	< 75	< 71
	80-16	< 75	< 71
	65-20	< 76	< 71
	80-20	< 76	< 71

Table 2 - Noise values for HD - HG series



POWER / POLES	NOISE PRESSURE (Lp) [dB(A)]			NOISE PRESSURE (Lp) [dB(A)] (ATEX)		
	2 poles	4 poles	6 poles	2 poles	4 poles	6 poles
0.75	57	47	48	62	51	46
1.1	57	51	48	62	54	46
1.5	62	51	52	69	54	55
2.2	62	52	54	69	55	57
3	66	52	57	72	55	60
4	67	55	57	72	60	60
5.5	70	57	57	73	64	60
7.5	70	57	61	75	67	64
9.2	73	60	-	75	67	-
11	76	62	61	76	69	64
15	76	62	61	76	69	67
18.5	76	64	65	76	70	69
22	79	65	65	74	70	69

Table 4 - Indicative noise emission values for three-phase motors

Graph 1 shows how to calculate the total noise emission of the pump-motor unit starting from the information contained in the tables above. Calculate the difference between the two sources. Identify the value obtained on the X axis and calculate the Y value (increase in dB) on the curve and add it to the higher value between pump and motor.

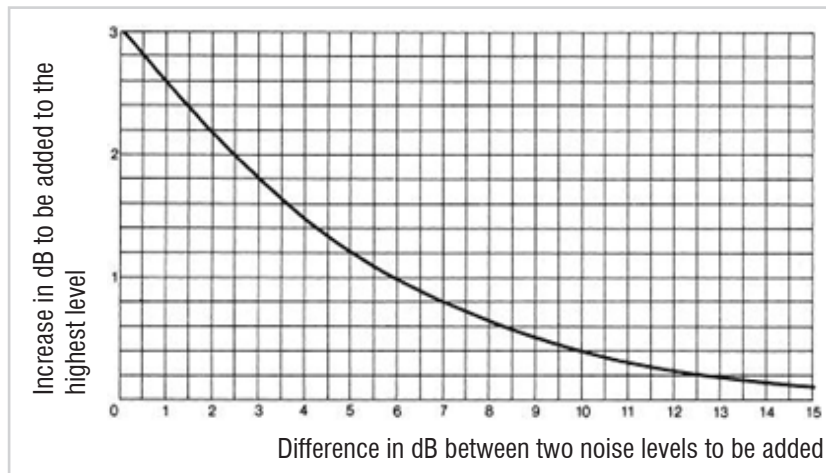

Graph 1 - Calculation of the dB increase for two noise sources



4. RECEIPT, HANDLING AND STORAGE

4.1. PACKAGING

The pump is assembled by Salvatore Robuschi & C. S.r.l. and packaged as indicated in the order confirmation.

The packaging is made in accordance with the mode of transport. If handled with due care it is able to withstand minor impacts but cannot withstand falls or stacked loads.

4.1.1. REMOVAL OF PACKAGING AND HANDLING

When removing the packaging, take care to:

- Not damage the contents within.
- Correctly dispose of any waste.

The pump mouth guards must be removed only before connecting it to the pipes. In the event of removal for inspection purposes, the protections must be put back, at the end of the operation, in the same way and in the conditions in which they were found.

4.2. CHECKING ON RECEIPT

The material leaves Salvatore Robuschi & C. S.r.l. intact in all its parts and always travels at the risk of the recipient.

At machine delivery, the customer is obliged to check that there is no damage caused by transport.

In case of damage, please follow the instructions below:

- Leave the packaging as you received it, write the phrase "Ritiro con riserva" (Withdrawal under reserve) on the transport document
- Immediately ask the shipping company to verify the damage.
- Report the damage detected to Salvatore Robuschi & C. S.r.l..

4.3. TRANSPORT AND HANDLING

Salvatore Robuschi & C. S.r.l. uses packages and fixing systems suitable to ensure the integrity and proper conservation during transport, according to the means of transport used.

The handling procedures described in this paragraph shall be carried out by staff trained for such operations: suitably trained personnel to safely perform loading, unloading and handling operations by means of lifting equipment, and aware of accident-prevention rules.



CAUTION!

Salvatore Robuschi & C. S.r.l. shall not be held liable for any damage, to things or people, caused by accidents due to a failure to comply with the instructions provided in this manual.

4.3.1. TRANSPORTATION OPERATIONS



CAUTION!

Salvatore Robuschi & C. S.r.l. disclaims any liability for any damage to the component arising from failure to comply with the instructions provided.



IMPORTANT!

The lifting personnel must be authorised and trained to use the lifting equipment and devices, and must comply with the applicable regulations for personal protection.



IMPORTANT!

Before and during any type of handling operation of the pump, it is mandatory to take all the safety precautions dictated by the regulations in force on site and the internal ones of the company / plant where it will be installed.



TRANSPORT WITH FORKLIFT TRUCK



Operator qualification	Lifting equipment operator
Necessary PPE	
Lifting equipment	Forklift truck







CAUTION!
Only use suitable and approved lifting equipment, compatible for the dimensions and weight of the goods.

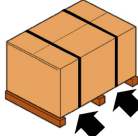

CAUTION!
Make sure nobody stops under and within the range of the lifting equipment.

Risk		Description and procedural information
Impact hazard		Danger of impact against protruding parts during handling phases. It is mandatory to wear appropriate PPE.
Crushing hazard		Danger of crushing during handling stages. It is mandatory to wear appropriate PPE.

To carry out the transport correctly, proceed as described:

STEP	ACTION	PICTURE
1	Place the forks of the forklift under the load surface.	
2	Make sure that the forks come out from the front of the load (at least 5 cm) to eliminate any risks of overturning of the transported part.	
3	Lift the forks until they are touching the load. Note: if necessary fix the load to the forks with clamps or similar devices.	
4	Slowly lift the load by a few tens of centimetres and check it is stable, making sure that the load's centre of gravity is positioned in the centre of the lifting forks.	
5	Tilt the upright backwards (towards the driver's seat) to facilitate the tilting moment and guarantee greater stability of the load during transport.	
6	Adapt the transport speed according to the flooring and type of load, avoiding sudden manoeuvres.	
7	Place the load in the chosen area.	



HANDLING WITH CRANE OR GANTRY



Operator qualification	Lifting equipment operator
Necessary PPE	
Lifting equipment	Crane or Gantry



CAUTION!
Only use suitable and approved lifting equipment, compatible for the dimensions and weight of the goods.



CAUTION!
Make sure nobody stops under and within the range of the lifting equipment.

Risk		Description and procedural information
Impact hazard		Danger of impact against protruding parts during handling phases. It is mandatory to wear appropriate PPE.
Crushing hazard		Danger of crushing during handling stages. It is mandatory to wear appropriate PPE.

To correctly carry out handling, proceed as described:

STEP	ACTION
1	Connect the belts / straps to the component in the appropriate grip points, depending on the type of pump to be moved - see image below.

MACHINERY

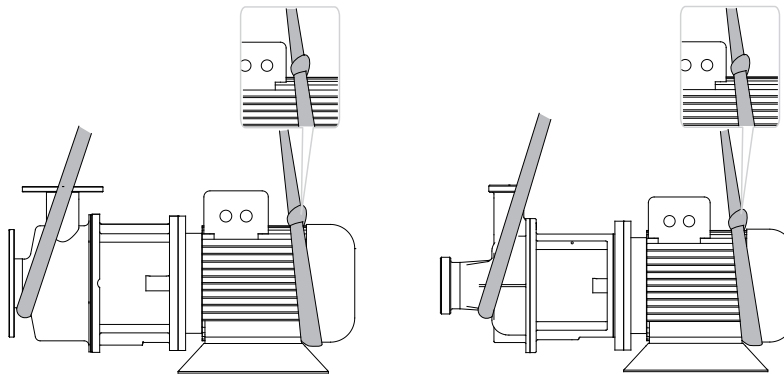

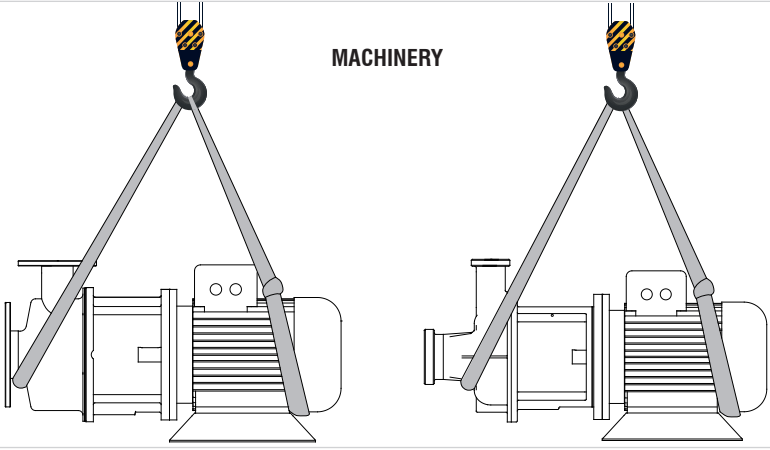
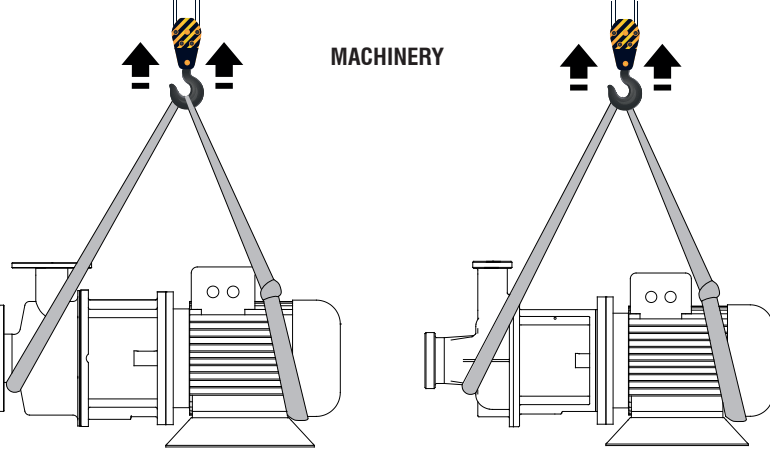
STEP	ACTION
2	Connect the belts / straps to the hook of a crane or gantry.
<div style="text-align: center;">  <p style="text-align: center;">MACHINERY</p> </div>	
3	Slowly lift the load by a few tens of centimetres and check it is stable, making sure that the centre of gravity of the pump is positioned in the centre of the lifting hook. Make sure that the pump is always properly balanced and in a horizontal position.
<div style="text-align: center;">  <p style="text-align: center;">MACHINERY</p> </div>	
4	Place the pump in the chosen area.

4.4. STORAGE

If the pump is not installed on the plant within 30 days of delivery, it must:

- Be checked
- Packaged again
- Stored with the correct precautions.



NOTE!

It is advisable to install the pump within 3 months of leaving the factory, otherwise follow the instructions below.

For correct storage it is necessary to comply with the following provisions:

- Store the pump in an enclosed, dry, clean place that is not directly exposed to solar radiation and any type of vibration.
- For storage over 3 months, remove the liquid contained in the pump and replace it. See last point, section b
- Avoid places where the ambient temperature is lower than 4°C
- Close any holes that can connect the inside of the pump with the outside
- Protect the inside and outside of the pump by:
 - a. Outside - anti-rust products and waterproof sheets
 - b. Inside - If compatible, ethylene glycol (antifreeze) is recommended, otherwise use other protective liquids compatible with the gaskets and elastomers present inside the pump, compatible with the pumped liquid and suitable for the storage temperature. Manually rotate the pump to distribute the liquid on all the surfaces. Close the mouth protections again.



5. FEATURES

5.1. PERFORMANCE AND OPERATING LIMITS

Flow rate and Head, if specified by the customer, are present on the plate.

The technical specifications of the pump are contained in the datasheet received in the order confirmation.

The pump can only be used for the conditions and liquids specified in the datasheet attached to the order confirmation.

If the limits are not specified, the following applies:

- Flow rate for short periods of operation: $Q_{min} = 10\%$ of the flow rate at the BEP (BEP = best performance point)
- Flow rate in continuous operation: $Q_{min} = 30\%$ of the BEP flow rate
- Maximum flow rate: $Q_{max} = 85\%$ of the curve bottom flow rate (If a flow meter is not available refer to the head at that point multiplied by the specific weight of the pumped liquid).

If the data sheet does not contain the working conditions, follow the instructions below:

- Clean liquid
- Non-aggressive liquid (it is the responsibility of the installer / user to check that the pump materials are suitable for the pumped liquid and the working temperature)
- Specific weight 1 kg/dm³
- Viscosity 1 cPs
- Liquid temperature MAX 50 °C
- Atmospheric suction pressure
- MAX 5m positive head
- Frequency 50 HZ

For operation outside the above limits, request an update from Salvatore Robuschi & C. S.r.l. specifying the model and serial number of the pump. Table 5 shows the maximum permissible pressure values in the pump casing (design pressure).

These values are valid for clean water at a temperature of 20°C.



CAUTION!

The design pressure is not the working pressure and can only be reached if the pump is equipped with adequate seals.

PUMPS	SIZE	DESIGN PRESSURE	HYDROSTATIC TEST PRESSURE
RS	20-08	4 bar	6 bar
	25-12, 32-12, 40-12, 32-16, 40-16, 50-16, 65-16, 50-20, 65-20	6 bar	9 bar
	32-20, 40-20	8 bar	12 bar
HD - HG	25-16, 25-19, 32-16, 40-16, 50-16, 65-16, 80-16	6 bar	9 bar
	32-20, 40-20, 50-20, 65-20, 80-20	8 bar	12 bar

Table 5 - Design pressure

5.2. PERMITTED ENVIRONMENTAL CONDITIONS

The permitted environmental conditions for the correct operation of the pump are those agreed with the customer and shown on the datasheet attached to the order confirmation. If not otherwise specified in the datasheet, the following conditions are to be considered valid:

PERMITTED ENVIRONMENTAL CONDITIONS	
Temperature	-20°C ≤ T ≤ +40°C
Environment	Non aggressive
Altitude	< 1000m
Installation	Indoor

5.3. LIMITS FOR ATEX PUMPS

For pumps operating in areas at risk of explosion and certified according to the 2014/34/EU directive, the actions provided in the specific Addendum accompanying the machine must be implemented and available, in the event of loss or wear, on the site www.salvatorerobuschi.com.





6. INSTALLATION

PUMP INSTALLATION	
Operator qualification	Specialised mechanical worker Manufacturer's technician
Necessary PPE	
Tools to be used	Hand tools



CAUTION!

The installation operations should only be performed by specialised, authorised personnel.

Risk		Description and procedural information
Crushing hazard		Danger of crushing during installation stages. It is mandatory to wear appropriate PPE.
Cutting hazard		Danger of cutting during installation stages. It is mandatory to wear appropriate PPE.
High voltage/electrocution hazard		Electrocution hazard during installation stages. It is mandatory to wear appropriate PPE.

To correctly carry out the installation, follow the following stages:

STAGE	ACTION
1	Foundation creation/inspection.
2	Pump installation and fixing.
3	Pipe connection and inspection.
4	Mechanical checks and preliminary checks.
5	Installation of protections (if necessary).
6	Electrical connection.



6.1. FOUNDATION

The surfaces on which the pump will be installed must be checked and sized by specialised technicians.

The structure of the construction must be suitable for the weight and dimensions of the machine to minimise the vibrations and torsions transmitted by the electric pump unit and must be done according to the class of concrete most suited to the environment in which it will operate. (for example: XO, XC1, XS1, etc...) in compliance with the provisions of UNI EN 206: 2016 and UNI 11104: 2016 standards.

Alternatively, a structure can be made in a different material but with the same structural requirements.

The base support must be perfectly levelled regardless of the type of structure chosen.

6.2. INSTALLATION AND FIXING

If you had opted for a masonry foundation solution, use chemical anchors or foundation bolts to fix it, first checking that the structure is consolidated, finished, dry and clean.

In case of a structure in steel beams, make sure that the structure is firmly bolted and anchored to the supporting surface and the vibrations and torsions due to the pump and the pipes do not change the initial position.

To correctly carry out the installation and fixing, follow the following stages:

STAGE	ACTION
1	Put the pump on the foundation, centring it with the fixing bolts.
2	Check that the pump or base are kept level with the floor.
3	If necessary, insert shims between the base plate and the support surface in order to compensate for any deformation.
4	Tighten the bolts fully.

6.3. PIPES

6.3.1. MAXIMUM PERMISSIBLE LOADS

The forces and moments acting on the pump flanges due to pipeline loads can cause a misalignment between the pump shaft and that of the drive motor, a deformation of the pump casing, or an excessive stress on the fixing bolts between the pump and base plate.

The maximum admissible load values on the flanges are shown in Table 6.

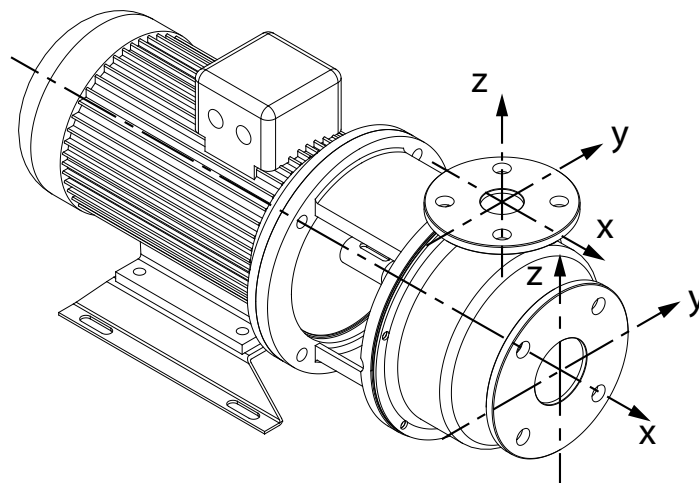

DISCHARGE (RSM STEEL)									SUCTION (RSM STEEL)								
DN	Fy	Fz	Fx	Ftot	My	Mz	Mx	Mtot	DN	Fy	Fz	Fx	Ftot	My	Mz	Mx	Mtot
3/4" M	25	30	26	46	21	25	32	46	1" M	26	25	30	46	21	25	32	46
1" F	37	45	39	68	32	37	47	68	1" 1/4 F	95	89	110	173	79	89	116	168
32	89	110	95	173	79	89	116	168	50	158	142	173	273	105	121	147	215
40	105	131	116	205	95	110	137	200	65	194	179	221	347	116	126	158	231
50	142	173	158	273	105	121	147	215	80	236	215	263	415	121	137	168	247
65	142	173	158	273	105	121	147	215	100	236	215	263	415	121	137	168	247

DISCHARGE (RSA STEEL)									SUCTION (RSA STEEL)								
DN	Fy	Fz	Fx	Ftot	My	Mz	Mx	Mtot	DN	Fy	Fz	Fx	Ftot	My	Mz	Mx	Mtot
25	37	45	39	68	32	37	47	68	25	26	25	30	46	21	25	32	46
32	89	110	95	173	79	89	116	168	32	95	89	110	173	79	89	116	168
40	105	131	116	205	95	110	137	200	50	158	142	173	273	105	121	147	215
50	142	173	158	273	105	121	147	215	65	194	179	221	347	116	126	158	231
65	142	173	158	273	105	121	147	215	80	236	215	263	415	121	137	168	247
									100	236	215	263	415	121	137	168	247

DISCHARGE (HDM - HGM STEEL)									SUCTION (HDM - HGM STEEL)								
DN	Fy	Fz	Fx	Ftot	My	Mz	Mx	Mtot	DN	Fy	Fz	Fx	Ftot	My	Mz	Mx	Mtot
25	74	89	79	137	63	74	95	137	40	116	105	131	205	95	110	137	200
32	89	110	95	173	79	89	116	168	50	158	142	173	273	105	121	147	215
40	105	131	116	205	95	110	137	200	65	194	179	221	347	116	126	158	231
50	142	173	158	273	105	121	147	215	80	236	215	263	415	121	137	168	247
65	142	173	158	273	105	121	147	215	100	236	215	263	415	121	137	168	247
80	142	173	158	273	105	121	147	215	125	236	215	263	415	121	137	168	247

DISCHARGE (HDA - HGA STEEL)									SUCTION (HDA - HGA STEEL)								
DN	Fy	Fz	Fx	Ftot	My	Mz	Mx	Mtot	DN	Fy	Fz	Fx	Ftot	My	Mz	Mx	Mtot
25	74	89	79	137	63	74	95	137	40	116	105	131	205	95	110	137	200
32	89	110	95	173	79	89	116	168	50	158	142	173	273	105	121	147	215
40	105	131	116	205	95	110	137	200	65	194	179	221	347	116	126	158	231
50	142	173	158	273	105	121	147	215	80	236	215	263	415	121	137	168	247
65	142	173	158	273	105	121	147	215	100	236	215	263	415	121	137	168	247
80	142	173	158	273	105	121	147	215	125	236	215	263	415	121	137	168	247

Table 6 - Values of the maximum permissible loads



6.3.2. FIXING OF PIPES

Suction and discharge pipes have to be supported independently from the pump. Be sure that pipes are installed to allow the perfect matching of flanges and counterflanges, avoiding stress transmission to the pump.

A compensation bellows is also necessary to absorb stresses or expansions caused by the temperature.

If compensation joints are installed, the pipes must be supported near the pump in such a way so it is not subjected to the thrusts caused by the lengthening of the pipes.

6.3.3. SUCTION AND DISCHARGE PIPES

The suction pipe, which must never be smaller in diameter than the suction port of the pump, must be sized according to the suction conditions and considering the characteristics of the product and the temperature.

Check that the speed of the pumped fluid is between 0.5 and 2m / sec. It is necessary to ensure that the suction pipe joints are perfectly sealed to prevent air going in. The suction pipe, in the horizontal sections, must have a positive slope towards the pump to avoid air pockets forming inside the pipeline. Check that there are no points in the pipe where air can accumulate which would compromise the operation of the pump. Should the pump run with a negative slope in the suction line, install a foot valve at the end of the pipe to maintain priming and a valve for filling the pipe.

The free end of the suction pipe must be at least 1.5 diameters away from the wall or from the bottom of the tank and built in order to avoid the formation of vortices or the entry of air. If the liquid contains dissolved air, it must be eliminated with bulkheads or the like. With the presence of air the pump's performance is lower than the curve's. Check that the system NPSHa is always higher than the pump NPSHr.

The discharge pipe must never be smaller in diameter than the discharge port of the pump and must be sized in accordance with the system requirements (length - no. curves etc.). The maximum speed of the pumped liquid must be 2.5 m/sec.

Also fit a check valve on the discharge pipe to protect the pump from excessive back-pressures and reverse rotation after each stop.

The following images show some examples of wrong / correct installation of the pump:

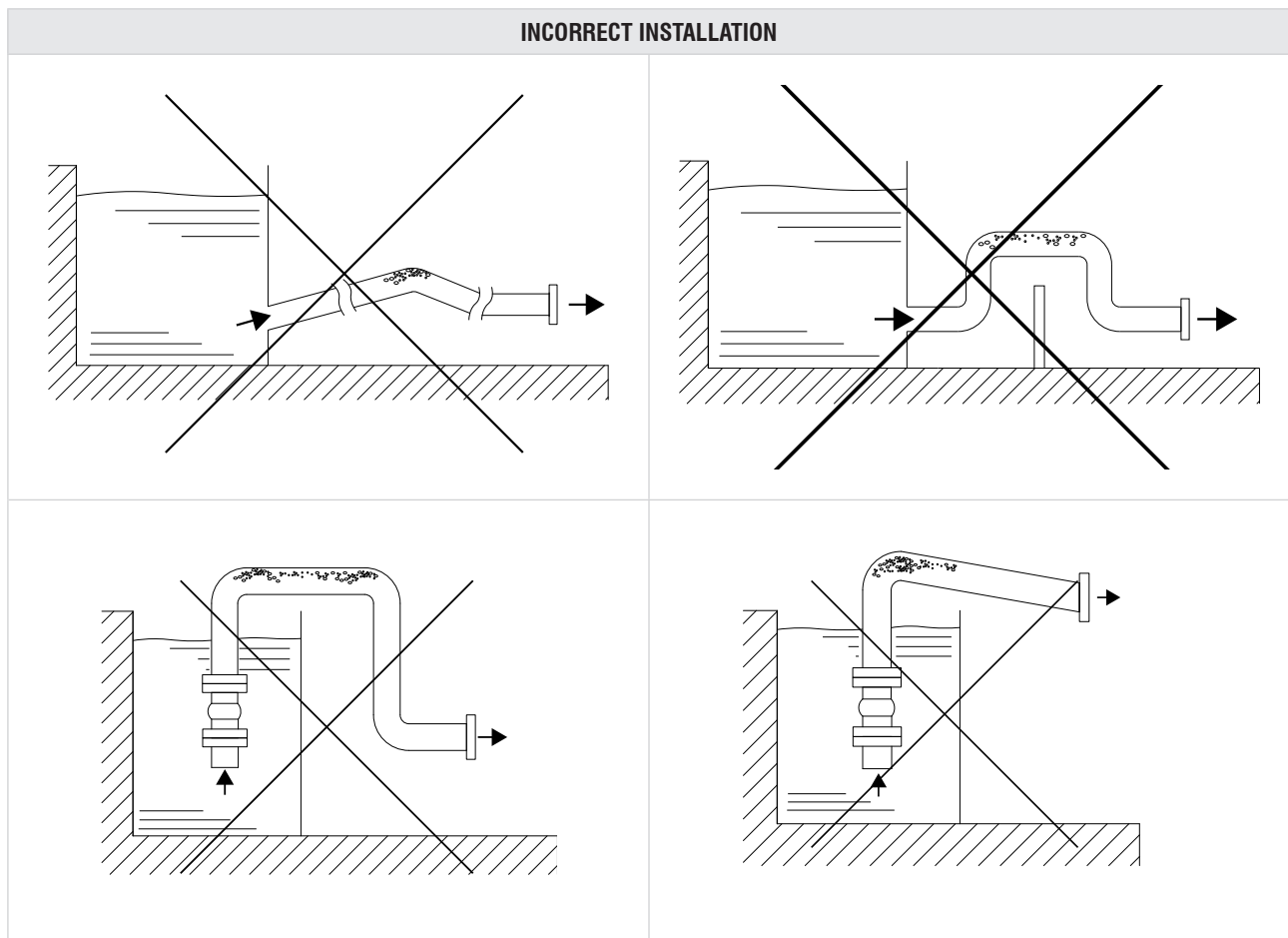

INCORRECT INSTALLATION

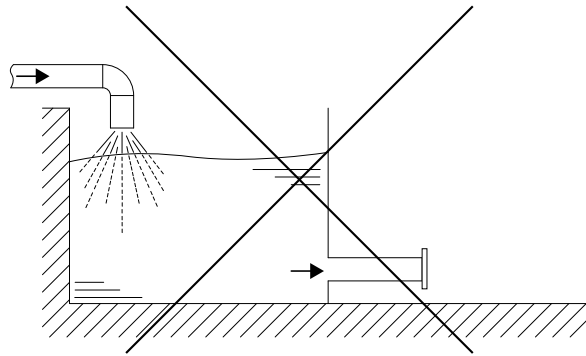
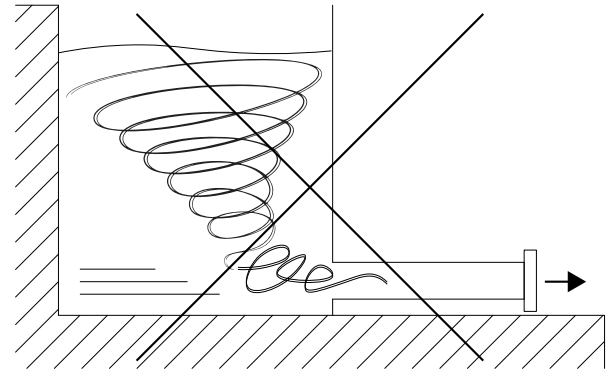
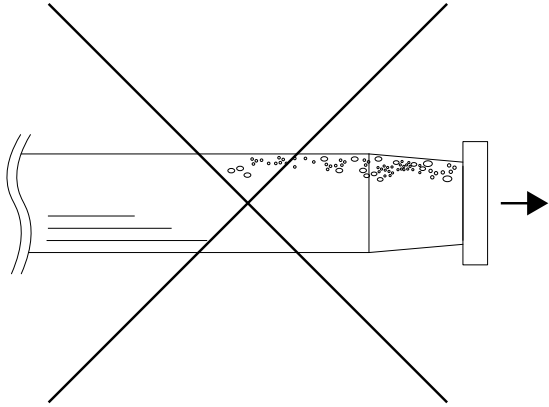

CORRECT INSTALLATION

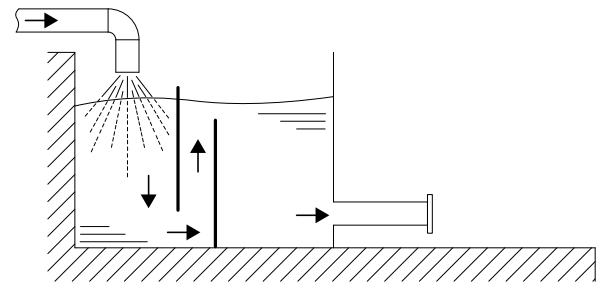
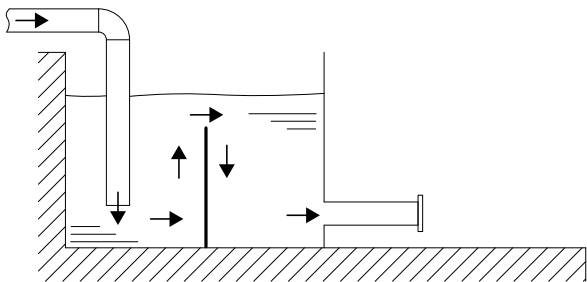
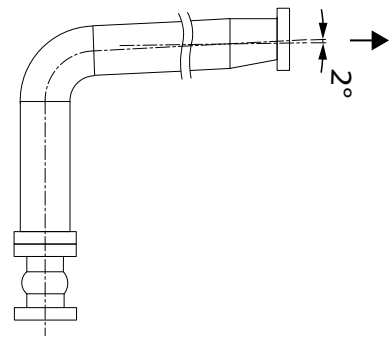
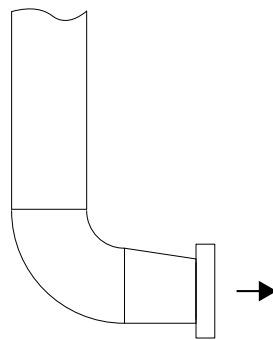
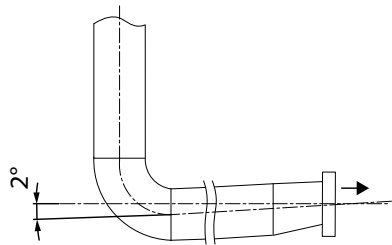

CORRECT INSTALLATION

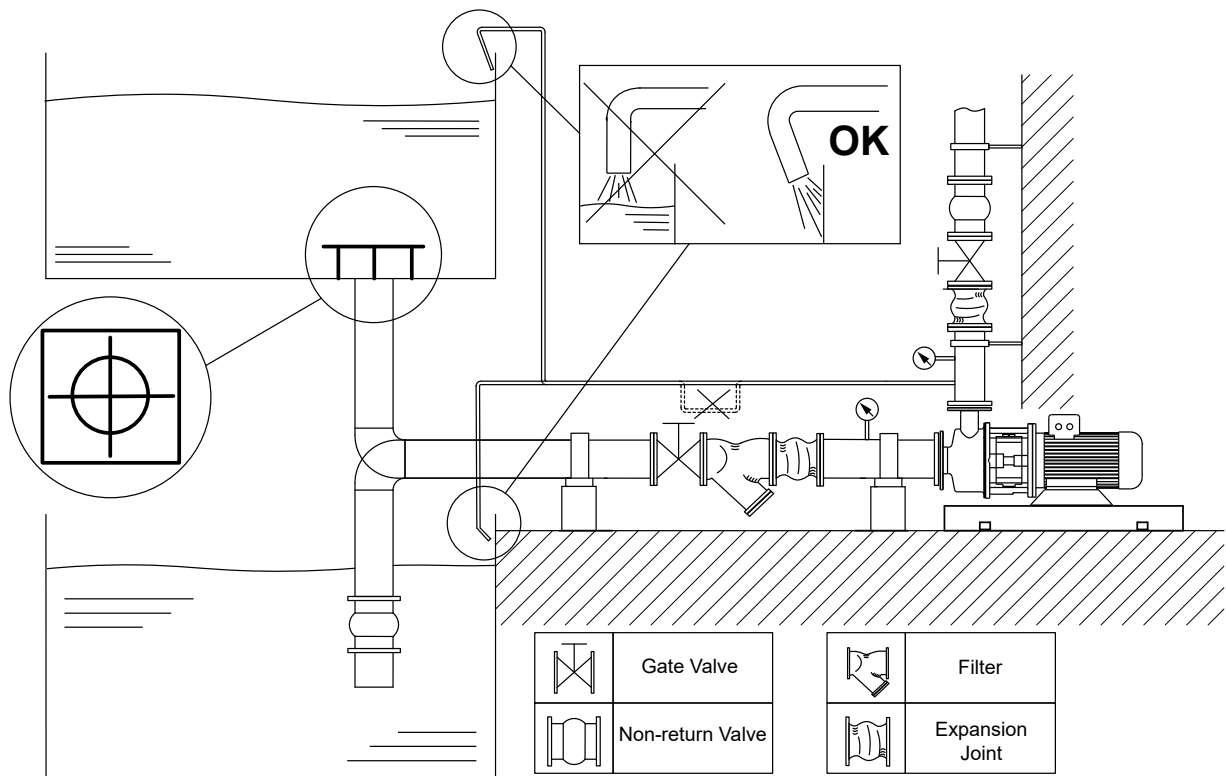

6.3.4. FILTERS

For new systems, after modifications to the pipes or if the system has been opened for maintenance, it is necessary to clean the system carefully before starting or apply a temporary filter on the suction suitable to retain any solids (slag, bolts, gaskets, rags, etc.) which could damage the pump components. Once the washing phase is over, if considered appropriate, the filter can be removed. The filter is not necessary for Vortex impeller pumps (RS series). If the liquid to be pumped contains solids bigger than the free passage clearance of the pump, install a permanent filter and a clogging control system. Check the filter flow resistance and make sure that the system NPSH is always higher than that of the pump.



6.3.5. VENT

Some models (**A**) have a vent hole under the discharge flange to which a valve must be applied.

For all other models (**B**) install a 1/4" air vent valve immediately after the discharge flange and before any other component. In the presence of dangerous liquids the vent must be conveyed to a safe area. The vent is very important and necessary in the start-up / removal phase to allow the correct filling / emptying of the pump.

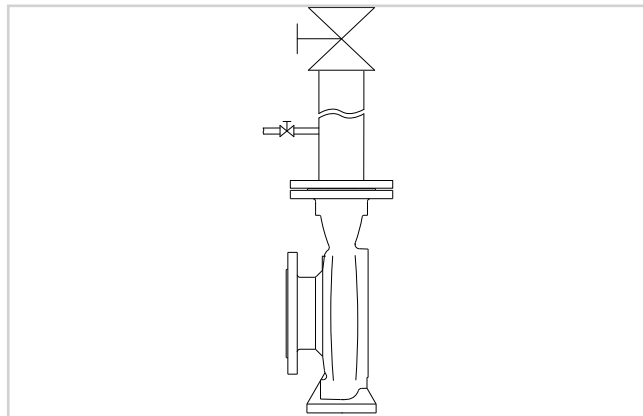

6.3.6. DRAIN

Install a drain valve immediately before the suction port.

In the presence of dangerous liquids, drainage is absolutely necessary and must be conveyed to a safe area. Drainage is very important during maintenance to enable correct and safe emptying of the pump.

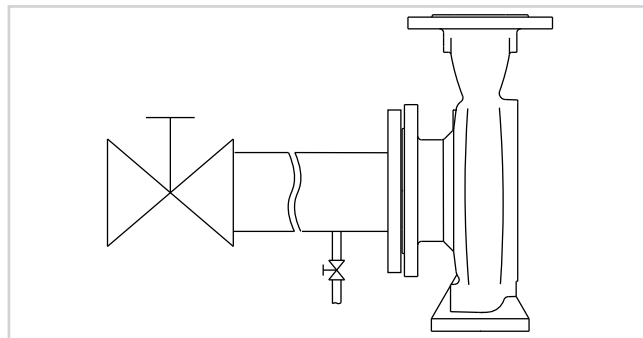

6.3.7. CONTROL INSTRUMENTS

Install a pressure gauge on the discharge pipe and a hand-vacuum gauge on the suction pipe. These instruments are necessary for the correct regulation of the pump and are essential for the diagnosis of faults and any system malfunctions.

In the event of a complaint on the pump's performance, the pressure values on the suction and discharge lines will be requested, which are found near the pump itself. The connections of the pressure gauges must be in such a position so that the read values are not distorted by valves, filters or other elements that cause pressure drops.

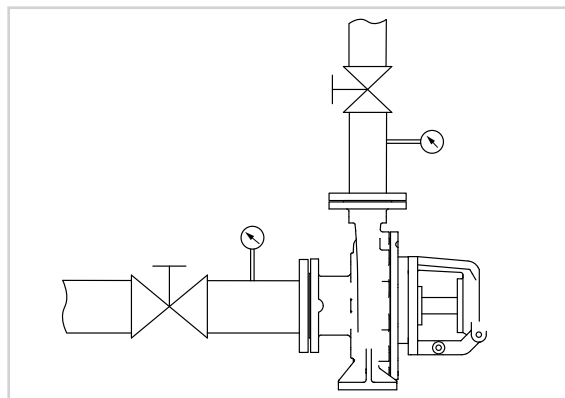

6.3.8. AUXILIARY PIPING SEALS AND HEATING / COOLING CHAMBERS

Refer to APPENDIX A for instructions on connecting and commissioning seals and heating / cooling chambers.

The auxiliary flushing, barrier, heating or cooling pipes must be connected to the connections provided on the pump. This is necessary for the correct lubrication and cooling of the mechanical seals and packing ring seals.



IMPORTANT!

Absence of and incorrect lubrication can lead, in addition to damage to the sealing parts, also to the triggering of combustion reactions caused by overheating due to friction.

6.4. MECHANICAL CHECKS AND PRELIMINARY CHECKS

Before proceeding with the commissioning of the pump, it is necessary to proceed with the following checks:

6.4.1. COUPLING GUARD



IMPORTANT!

According to the security rules, pumps can work only if the shaft is correctly protected.

6.4.2. ROTATION

Check that the pump rotates freely by hand.

6.5. INSTALLATION OF PROTECTIONS



IMPORTANT!

If the pump is supposed to work with cold, warm or dangerous liquid, the necessary cautions have to be taken to prevent any possible accident.

It is compulsory to install adequate protections on the pump, on the fittings and on the pipes and put a safety perimeter around the machine so that any ejection of pressurised fluid, in the event of malfunction or corrosion of the parts, does not cause damage to property or persons. This requirement also refers to the installation of packing seals where the intrinsic nature of the seal provides for a controlled loss of the pumped liquid.



6.6. ELECTRICAL CONNECTION

ELECTRICAL CONNECTION	
Operator qualification	Electrical maintenance engineer
Necessary PPE	
Tools to be used	Hand tools



CAUTION!

The installation operations should only be performed by specialised, authorised personnel in accordance with local rules.

Risk		Description and procedural information
High voltage/electrocution hazard		Electrocution hazard during installation stages. It is mandatory to wear appropriate PPE.

Before setting up the electrical connection, make sure that:

- the maintenance engineer is aware of the regulations in force in the country of installation;
- the supply voltage corresponds to the voltage on the motor plate;
- the section of the electrical cables used is adequate to the absorption;
- the earthing of the circuit is in compliance with standards EN 60204-1;
- the materials used in the earthing system have adequate strength or adequate mechanical protection.
- the supply voltage corresponds to the voltage indicated on the motor plate.
- person responsible for the installation on site must make sure that the earth connection is carried out first and that the entire system is built in compliance with the regulations in force.
- install a device for disconnection from the network.
- regarding motor protection, install a switch or a thermal relay for the current indicated on the motor plate, plus 5%.
- if available, connect the PTCs and any other probes provided.



7. USE



CAUTION!









The pump must only be used for the purpose intended by Salvatore Robuschi & C. S.r.l.
Salvatore Robuschi & C. S.r.l. will not be held responsible for damage caused due to improper use of the pump.

7.1. PRELIMINARY INSPECTIONS

The following checks must be performed before commissioning the pump.

- Check that the pump is positioned on a surface able to withstand the weight.
- Check operation of safety devices.
- Check that the pump has been connected to the power mains.
- Check that the power supply phases are correct.
- Check that the pump is not in "Maintenance" status.

7.2. START-UP

Risk		Description and procedural information
Crushing hazard		Danger of crushing during installation stages. It is mandatory to wear appropriate PPE.
Cutting hazard		Danger of cutting during installation stages. It is mandatory to wear appropriate PPE.
Entanglement hazard		Entanglement danger during operation stages. It is mandatory to wear appropriate PPE.
Sliding or abrasion hazard		Sliding, abrasion hazard, during operation stages. It is mandatory to wear appropriate PPE.
High-pressure fluid injection or ejection hazard		High-pressure fluid injection or ejection hazard during operation stages. It is mandatory to wear appropriate PPE.
Danger of burning and burns		Danger of burning and burns during operation stages. It is mandatory to wear appropriate PPE.
Danger of ejection of parts		Danger of ejection of parts during operation stages. It is mandatory to wear appropriate PPE.
Danger of unexpected ejection of machinery components or fluids		Danger of unexpected ejection of machinery components or fluids during use. It is mandatory to wear appropriate PPE.
High voltage/electrocution hazard		Electrocution hazard during use. It is mandatory to wear appropriate PPE.



FORBIDDEN!

No access to persons with active implanted cardiac devices.



CAUTION!

The pump must never run dry.
The pump can only be started if filled with liquid.



7.3. PIPING FILLING



IMPORTANT!
Pipe filling operations must be carried out with the pump STOPPED.

7.3.1. PRIMED CONDITION (POSITIVE GEODETIC SUCTION HEAD)

To fill, proceed as follows:

STEP	ACTION
1	Open the discharge valve and the vent valve to let the air out. In the presence of dangerous liquids it is essential to use the vent valve conveyed in a safe area (See "AIR VENT" paragraph).
2	Fill the pump by slowly and fully opening the suction valve.
3	When you are sure that the pump is full, fully close the discharge gate valve and the vent valve.
4	Check the pressure inside the pump casing using the pressure gauge on the suction side. If the value read is higher than 1 bar, make sure that this value complies with that indicated in the order confirmation.

7.3.2. NON-PRIMED CONDITION (NEGATIVE GEODETIC SUCTION HEAD)

To fill, proceed as follows:

STEP	ACTION
1	Open the discharge valve and the vent valve to let the air out. In the presence of dangerous liquids it is essential to use the vent valve conveyed in a safe area (See "AIR VENT" paragraph).
2	Completely fill the suction pipe and the pump casing using the appropriate loading valve.
3	When you are sure that the pump is full, fully close the discharge gate valve and the vent valve.

7.4. PACKING GLAND PRELIMINARY REGULATION



IMPORTANT!
Preliminary regulation operations of the packing gland must be carried out with the pump STOPPED.

After filling the pump, check that the packing ring drips slightly.
If this does not happen, loosen the packing gland gradually and alternately.

7.5. HEATING / COOLING / SEALS SUPPLY

If seals with flushing are provided, open the supply and adjust the amount of liquid in the quantity and / or the pressures indicated in APPENDIX A. Failure or incorrect flushing can irreparably affect the functioning of the seals.

If cooling or heating is required for the seal chamber and / or the pump casing, open the auxiliary liquid supplies by adjusting it's circulation.

If the pump is provided with steam preheating chambers, the steam must flow in from the upper connections.

The flushing pressure must not exceed 6 BAR with a temperature from 5° to 140° C unless otherwise agreed.



7.6. ROTATION DIRECTION TEST

To perform the rotation direction test, proceed as described:

STEP	ACTION
1	Start the pump for an instant with the discharge gate valve slightly open (20% opening).
2	Make sure the rotation's direction is the one shown by the arrow on the pump casing: if it rotates the opposite way, swap the connections of two phases.

7.7. PUMP START



FORBIDDEN!
The pump must never run dry.

Maximum power allowed for direct start-up (for data not in the table, start with star-delta, soft-start or with inverter).

Poles / rpm	Power (kW)
2P / 3000 rpm	Up to 30
4P / 1500 rpm	Up to 15
6P / 1000 rpm	Up to 11

To start the pump, proceed as described:

STEP	ACTION
1	Fully open the suction valve and open the discharge valve slightly (20% opening).
2	Start the pump.
3	When the motor has reached full throttle, slowly open the discharge valve and adjust the operating point.
4	Check that the current absorbed at full speed does not exceed the rated current.
5	Check that the work head is not lower than the curve bottom.

Number of start-ups allowed:

Motor power (kW)	max no. start-ups per hour
Up to 7.5	15
Up to 30	12
Over 30	10

7.7.1. CHECKS AFTER START-UP

To check after start-up, proceed as described below:

STEP	ACTION
1	Check that the pump turns in the indicated rotation direction.
2	Check that there is no excessive noise or vibration indicating a malfunction
3	Check that there are no leaks from the casing, from the seal (excluding Packing ring) and from the connections between the flanges and pipes.



7.7.2. ADJUSTMENT OF PACKING GLAND AFTER START-UP

Immediately after starting the pump, check that there is a constant drip of about one drop every 3 seconds.

Alternately loosen or tighten the gland screws by 1/4 of a turn to increase or decrease the dripping and check for about 10 minutes that it remains constant. Otherwise repeat the adjustment.

If there are no leaks with the pump started STOP IMMEDIATELY.

If necessary, contact the Salvatore Robuschi & C. S.r.l. technical department

7.8. STOP

If the system is equipped with non-return valves, as described in the "SUCTION AND DISCHARGE PIPES" paragraph, to stop the pump it is sufficient to stop the motor.

If the non-return valves are not present, stop the motor and close the discharge valve to prevent the reverse rotation of the pump for a long time.

Subsequently and independently of the aforementioned conformation:

STEP	ACTION
1	Close the suction valve (if present).
2	Close the auxiliary liquid valves (if present).
3	In case of shutdown with temperatures that could freeze the flushing liquid, drain the seal chamber.
4	In case of shutdown with temperatures that could freeze the pumped liquid, drain the pump casing.

For extended stops, see the paragraph "EXTENDED STOPS"

7.9. EXTENDED STOPS

In the event of extended stops, the pump must be started for a few minutes at least once a month.

In case this is not possible, before the restart of the pump verify / check that:

- inside there are no incrustations or deposits that could obstruct the impeller and / or prevent its free rotation;
- the condition of the impeller, the tightening of the ogive, that there is not excessive and non-uniform wear of the blades at the inlet and outlet and, where present, of the ring or wear plate;
- the correct tightening of the casing screws (APPENDIX B);
- all the checks and inspections contained in the "CHECKS AND MAINTENANCE" chapter.

If the pump is removed from the system, proceed with the instructions in the "STORAGE" section after having fully cleaned and dried the hydraulics and all the components in contact with the pumped fluid.



8. CHECKS AND MAINTENANCE



CAUTION!

The maintenance operations must be carried out by qualified and authorised personnel.



CAUTION!

Perform maintenance operations when the pump is off.

Risk		Description and procedural information
Entanglement hazard		Entanglement danger during operation stages. It is mandatory to wear appropriate PPE.
Sliding or abrasion hazard		Sliding, abrasion hazard, during operation stages. It is mandatory to wear appropriate PPE.
High-pressure fluid injection or ejection hazard		High-pressure fluid injection or ejection hazard during operation stages. It is mandatory to wear appropriate PPE.
Danger of burning and burns		Danger of burning and burns during operation stages. It is mandatory to wear appropriate PPE.
Danger of ejection of parts		Danger of ejection of parts during operation stages. It is mandatory to wear appropriate PPE.
Danger of unexpected ejection of machinery components or fluids		Danger of unexpected ejection of machinery components or fluids during use. It is mandatory to wear appropriate PPE.
High voltage/electrocution hazard		Electrocution hazard during use. It is mandatory to wear appropriate PPE.

8.1. SAFETY INFORMATION FOR CHECKS AND MAINTENANCE

The following information is to be considered supplementary to the "SAFETY REQUIREMENTS" paragraph.



CAUTION!

Disconnect the power supply before any installation, maintenance and disassembly, making sure that the lifesaving devices are operating correctly.



CAUTION!

It is necessary that the maintenance operations are carried out by using suitable equipment and in rooms suitable for ensuring the maximum safety of the operators.



FORBIDDEN!

It is forbidden to remove the guards of the coupling or of the rotating shafts and any other safety protection during operation of the machine. If the protections are removed for maintenance, inspection operations or machine stop, they must be restored correctly and in their entirety before starting up again.



IMPORTANT!

Use only original or authorised spare parts from Salvatore Robuschi & C. S.r.l.

The use of any other non-foreseen or unauthorised spare part absolves Salvatore Robuschi & C. S.r.l. from any liability in case of damage and invalidates the pump warranty.



8.2. PERIODIC CHECKS



CAUTION!

Disconnect the power supply before any installation, maintenance and disassembly work, and ensure it cannot be accidentally restored.

8.2.1. LUBRICATION

8.2.1.1. Lubrication with grease

For electrical motor with grease nipples, periodically every 2500 hours of operation, replace the lubrication grease of the motor bearings. For lubrication with grease, see the next Table

N.L.G.I	RECOMMENDED GREASE TYPE
3	ESSO - BEACON EP2
	MOBIL - MOLBILUX EP2
	SHELL - ALVANIA EP
	GREASER

8.2.2. FLUSHING

Consult APPENDIX A and check, depending on the version (see paragraph "PUMP IDENTIFICATION CODES") and on the Plan, that the flow rate, pressure, level and / or temperature are correct.

8.2.3. PERFORMANCE

Check periodically or after maintenance work and / or any changes to the layout of the system, that the pump performance is as defined in the pump datasheet and the performance curves of the same. (Also consult the Chapter "FEATURES").

8.2.4. MOTOR

Check that the power absorbed by the electric motor is within the plate limits. Periodically check the efficiency of the electrical protections and the integrity of the connections.

8.2.5. PROTECTIONS

Check periodically and after every maintenance operation that the protections are present and correctly fixed: coupling guard, seal guards and, where present, flange protections, pipes and any other element provided to guarantee the safety of the operators (See Paragraph "INSTALLATION OF PROTECTIONS").



8.2.6. SEALS

8.2.6.1. Mechanical seal

The mechanical seal does not require maintenance. Except for possible initial leaks after commissioning, the mechanical seal on the shaft must operate without leaks. **Avoid dry operation.**

When a leak occurs which increases gradually, the seal must be replaced.

Periodically check that the working conditions of the flushes (where present) correspond to that indicated in APPENDIX A.

8.2.6.2. Packing gland

There must be a slight dripping in the pumps with stranded seal.

When dripping through the stuffing box becomes excessive and it cannot tighten any further, change the seal rings.

Use seal rings suitable for the liquid to be pumped.

Seal rings have to be cut properly (see Figure 3 and Table 11).

It is necessary to offset the gasket cuts so that they do not match each other.

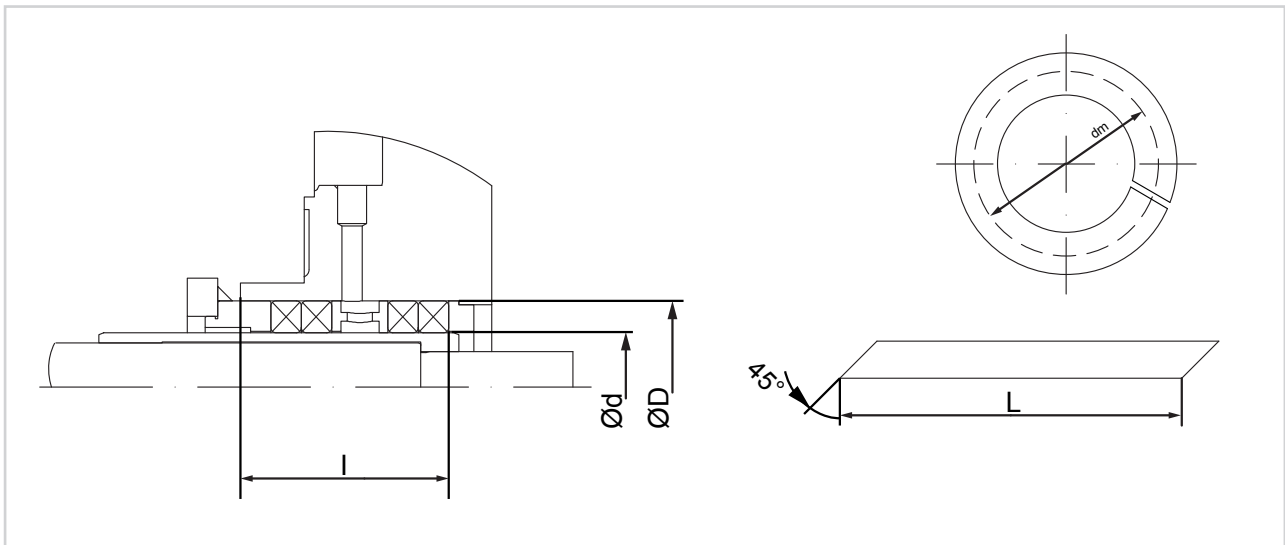

Figure 3 - Packing gland

Shaft	Seal Ø	Chamber Dimensions		Packing Ring	N° of rings with hydraulic ring	N° of rings without hydraulic ring
	d [mm]	D [mm]	l [mm]			
24	24	40	45	8	4	5
33	33	49	51	8	5	6

Table 11 – Dimensions and number of packing gland elements

8.2.7. INSTRUMENTATION AND AUXILIARY DEVICES

Check the efficiency of the instrumentation (pressure gauges, etc.) and of the accessories necessary for the adjustment and proper operation of the pump.



9. DISASSEMBLY AND REASSEMBLY



CAUTION!

The disassembly and reassembly operations must be carried out by qualified and authorised personnel.



CAUTION!

Carry out the disassembly and reassembly when the pump is off.

Risk		Description and procedural information
Entanglement hazard		Entanglement danger during operation stages. It is mandatory to wear appropriate PPE.
Sliding or abrasion hazard		Sliding, abrasion hazard, during operation stages. It is mandatory to wear appropriate PPE.
High-pressure fluid injection or ejection hazard		High-pressure fluid injection or ejection hazard during operation stages. It is mandatory to wear appropriate PPE.
Danger of burning and burns		Danger of burning and burns during operation stages. It is mandatory to wear appropriate PPE.
Danger of ejection of parts		Danger of ejection of parts during operation stages. It is mandatory to wear appropriate PPE.
Danger of unexpected ejection of machinery components or fluids		Danger of unexpected ejection of machinery components or fluids during use. It is mandatory to wear appropriate PPE.
High voltage/electrocution hazard		Electrocution hazard during use. It is mandatory to wear appropriate PPE.

9.1. SAFETY INFORMATION FOR DISASSEMBLY AND REASSEMBLY

The following information is to be considered supplementary to the "SAFETY REQUIREMENTS" paragraph.



CAUTION!

Disconnect the power supply before any installation, maintenance and disassembly, making sure that the lifesaving devices are operating correctly.



CAUTION!

It is necessary that the disassembly and reassembly are carried out by using suitable equipment and in rooms suitable for ensuring the maximum safety of the operators.



9.2. PRELIMINARY OPERATIONS



CAUTION!

Disconnect the power supply before any installation, maintenance and disassembly work, and ensure it cannot be accidentally restored.

- Check that the pump is off.
- The pump casing and pipes must be cooled to room temperature.
- Close the system valves to isolate the pump.
- Close all the valves of the flushes and other auxiliary fluids.
- If the valves are out of use or not present, inform the safety officer and define a suitable intervention procedure. Then empty the system and the auxiliary circuits.
- If the pump works with dangerous liquids or which pose a health risk, decontaminate and clean the pump and the room in which it is located.
- Make sure that the pressure inside the pump casing and the auxiliary circuits is atmospheric. If it is higher, pay attention to the opening of the caps, fittings or flanges because the liquid will come out with force causing jets. Always open slowly, carefully and protect yourself to prevent contact with the liquid.

9.2.1. DRAIN

- Drain the pump casing using the special valve on the suction pipe. In particular, in the case of toxic, explosive or harmful substances, despite the fact that the pump has been cleaned, follow the instructions indicated in the paragraph "DRAIN". If the valve is not present and the liquid is not dangerous, remove the drain plug or slightly loosen the suction flange in order to empty the casing and pipes. The liquid must flow very slowly and in a controlled manner.
- In the event that, despite what is indicated in the paragraph "DRAIN", the valves and drainage lines are absent and the pump is used for pumping liquids which are dangerous or harmful to your health, Salvatore Robuschi & C. S.r.l. declines all responsibility for damage caused to property and / or persons during pump removal. The responsibility lies with the installer.

9.2.2. DISCONNECTION

- Check that the pump and pipes are completely empty.
- Remove the screws from the flanges or the connections to the pipes.
- Remove all the flushing connections and the auxiliary devices, marking their function in order to reposition them correctly when re-assembling the pump.

9.2.3. FINAL RECLAMATION

- Carefully remove any product residues present inside the pump and take all necessary measures for complete reclamation in accordance with the instructions of the safety officer.
- In the case of a pump with double seal: remove the liquid remaining inside the seal chamber.

9.3. INSTRUCTIONS FOR DISASSEMBLY AND REASSEMBLY OF THE PUMP

To disassemble and reassemble the pump, ask Salvatore Robuschi & C. S.r.l. for the dedicated manual, stating the model and serial number. **IT IS SPECIFICALLY PROHIBITED** to work on the pump without having this manual with you.

In case of difficulties or doubts in understanding the instructions it is mandatory to suspend the intervention, secure the pump and the workplace and contact Salvatore Robuschi & C. S.r.l.



10. SPARE PARTS

10.1. SPARE PARTS REQUEST, COMMISSIONING AND START-UP

To request spare parts, consult pump sections on our general catalogue or on our website www.salvatorerobuschi.com/Products and contact ricambi@salvatorerobuschi.com stating the model, serial number and identification code of the desired components.

Use only original or authorised spare parts from Salvatore Robuschi & C. S.r.l.

The use of any other non-foreseen or unauthorised spare part absolves Salvatore Robuschi & C. S.r.l. from any liability in case of damage and invalidates the pump warranty.

10.2. SPARE PARTS AND SPARE PARTS SET FOR THE FIRST TWO YEARS OF USE (DIN 24296)

PART No.	DESCRIPTION	NUMBER OF PUMPS							
		1	2	3	4	5	From 6 to 7	From 8 to 9	10 and above
210	Shaft	1	1	1	1	2	2	2	20%
230	Impeller	1	1	1	1	2	2	2	20%
135	Wear plate	1	1	1	1	2	2	2	20%
506	Deflector	1	1	1	1	2	2	2	20%
507	V.ring	1	1	1	1	2	2	2	20%
400.1	Hydraulic gaskets (Set)								
400.4									
400.5		2	4	4	5	6	8	8	80%
400.6									
400.7									
412.3									
PUMPS WITH MECHANICAL SEALS									
433.1	Complete Mechanical Seal (Set)								
433.2		1	2	2	2	3	3	4	40%
FOR PUMPS WITH PACKINGS GLANDS									
461	Packing glands (Set)	2	4	4	6	6	6	8	100%

Table 13 - Spare parts set for the first two years of use



10.3. START UP SPARE PARTS AND SPARE PARTS SET

PART No.	DESCRIPTION	NUMBER OF PUMPS							
		1	2	3	4	5	From 6 to 7	From 8 to 9	10 and above
400.1	Hydraulic gaskets (Set)								
400.4									
400.5		2	4	4	5	6	8	8	80%
400.6									
400.7									
412.3									
PUMPS WITH MECHANICAL SEALS									
433.1	Complete Mechanical Seal (Set)	1	2	2	2	3	3	4	40%
433.2									
FOR PUMPS WITH PACKINGS GLANDS									
461	Packing glands (Set)	2	4	4	6	6	6	8	100%

Table 14 – Start-up Spare parts set



11. SHIPPING TO SUPPLIER



CAUTION!

The disassembly and reassembly operations must be carried out by qualified and authorised personnel.



CAUTION!

Carry out the disassembly and reassembly when the pump is off.

Risk		Description and procedural information
Entanglement hazard		Entanglement danger during operation stages. It is mandatory to wear appropriate PPE.
Sliding or abrasion hazard		Sliding, abrasion hazard, during operation stages. It is mandatory to wear appropriate PPE.
High-pressure fluid injection or ejection hazard		High-pressure fluid injection or ejection hazard during operation stages. It is mandatory to wear appropriate PPE.
Danger of burning and burns		Danger of burning and burns during operation stages. It is mandatory to wear appropriate PPE.
Danger of ejection of parts		Danger of ejection of parts during operation stages. It is mandatory to wear appropriate PPE.
Danger of unexpected ejection of machinery components or fluids		Danger of unexpected ejection of machinery components or fluids during use. It is mandatory to wear appropriate PPE.
High voltage/electrocution hazard		Electrocution hazard during use. It is mandatory to wear appropriate PPE.

Before returning the pump to the supplier, follow the steps below:

STEP	ACTION
1	Perform the steps indicated in the chapter "DISASSEMBLY AND REASSEMBLY".
2	It is mandatory to send a signed declaration that reclamation of the pump has taken place. The customer is responsible for any damage to property or persons due to residues not removed. It is also mandatory to indicate the possible presence of residual risks and the appropriate precautions to be taken in carrying out maintenance.
3	Pack the pump properly and correctly.



12. END OF LIFE AND DISPOSAL

This product falls within the scope of the Directive 2012/19/EU concerning the management of waste electrical and electronic equipment (WEEE).

The appliance must not be disposed of with domestic waste as it is made of different materials that can be recycled at the appropriate facilities. Ask through the municipal authority regarding the location of the ecological platforms to receive the product for disposal and its subsequent correct recycling.

Furthermore, upon purchase of an equivalent appliance, the distributor is obliged to collect the product for disposal free of charge.

The product is not potentially dangerous for human health and the environment, not containing harmful substances as per Directive 2011/65/EU (RoHS), but if released into the environment it negatively impacts the ecosystem.

Read the instructions carefully before using the appliance for the first time.

It is recommended that you do not use the product for any purpose other than that for which it was intended, there being a danger of electric shock if used improperly.



The crossed-out bin symbol, on the label on the appliance, indicates the compliance of this product with the regulations regarding waste electrical and electronic equipment.

Releasing the equipment into the environment or illegal disposal of the equipment is punishable by law.

13. APPENDIX A – AUXILIARY CONNECTIONS AND SEAL FLUSHING

13.1. SEAL EXECUTION IDENTIFICATION

To identify the type of seal, see the paragraph "PUMP IDENTIFICATION CODE". The version is the one corresponding to point 6.

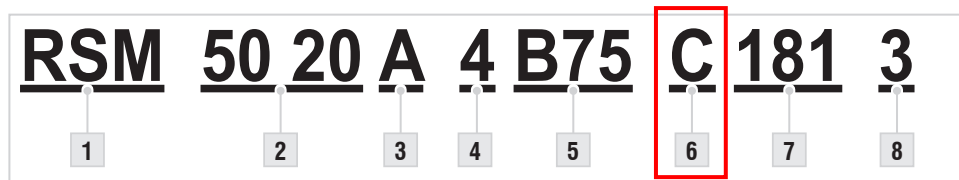

13.2. PLAN IDENTIFICATION

See order confirmation.

13.3. NAME

	ρ = Fluid density [kg/dm ³]
	P_a = Suction pressure [bar]
	P_m = Discharge pressure [bar]
	H_a = Suction head [m]
	H_m = Discharge head [m]
	$H_{tot} = H_m - H_a$
$H \approx (10 \cdot P) / \rho$	



13.4. AUXILIARY CONNECTIONS AND SEAL FLUSHING

(Version B) Packing gland.

See Paragraph "PACKING GLAND".

(Version C) Double back-to-back seals.



CAUTION!

The major cause of seal failure is due to insufficient or unstable pressure. Carefully follow the instructions.

The pressure P_c in the seal chamber must be equal to the working pressure P_m of the pump casing increased by 0.5 BAR.

The pressure P_m must be read immediately after the discharge outlet and must be the maximum reached when working.

With the pump stopped, the P_m pressure must not exceed 0.5 BAR. If higher, the seals must be pressurised.

The flushing liquid must be compatible with the pumped liquid because, due to increased pressure, it could enter the pump in the event of a fault. After compatibility check, the recommended liquids are: water for disposable circuits or glycol water, ethylene glycol, glycerine or Vaseline for closed circuits and barrels.

$$P_c = P_m + 0.5 \text{ Bar}$$

- Plan 54 from an external source:

DIAGRAM	CODE
	<p>THE SCHEME IS VALID FOR EVERY SIZE</p>

Check that the flushing line has sufficient pressure and that no drops occur due to the opening of other valves on the same line.

Fit a valve on the supply pipe (pump side) and, in sequence, a pressure gauge and a valve on the exhaust pipe (motor side).

Before starting the pump, open the valves completely, partially close the supply valve until you achieve a flow rate value double that in the table. Then close the discharge valve partially until you reach the pressure.

Check that the output flow is approximately that in the table. If necessary adjust the flow rate by acting on the valves again.

After starting the pump it is possible to change the flow rate based on the outlet temperature of the flushing liquid which must not exceed 45°C.



- **Plan 53.A** from flushing tank:

If not carried out in the factory, connect the tank to the seal seat according to the instructions below (see diagram in the paragraph "SALVATORE ROBUSCHI & C. S.r.l. TANK DIAGRAM").

Check that the tank is equipped with a pressure gauge. If it is missing, one should be installed with a scale suitable for the flushing pressure.

If not present, install a valve for filling and one for pressurisation.

Depending on requirements, it is possible to install (if not already present) a safety pressure switch between the supply valve and the barrel and a pressure reducer upstream from the above valve. The pressure switch is recommended to monitor the status of the tank and give a signal if the pressure falls below the minimum.

The signal must be brought to the panel and used to sound the alarm and turn off the pump. The pressure switch must be calibrated at a pressure lower than 0.3 bar with respect to that of the tank. If present, connect all the sensors and make sure they work.

If present (only on a third-party tank) connect the cooling coil.

Fill the tank to the maximum level or, if not indicated, just below the top of the visual level.

Pressurise the tank (+0.5 bar of the pump pressure) and then close the pressurisation valve.

Check that there are no air / gas or liquid leaks. Check by emptying it to the minimum level and by checking that all the safety devices intervene.

If the only indicator present is the pressure gauge, make sure it keeps the set pressure every 48 hours.

If the pressure drops, check the level and restore it.

If the level does not go down, but the pressure goes down, check the tightness of the pipes.

If the level drops, schedule maintenance.

Before starting the pump, if provided, open the cooling circuit.

After starting, check that the return pipe to the barrel (normally the side inlet) is warmer than the other. It is normal for the liquid to heat up and the pressure to rise: a maximum temperature of 50°C is tolerated.

For third-party tanks (with their own brand) follow the manufacturer's instructions.

$$P(\text{tank}) = P_m + 0.5 \text{ Bar}$$

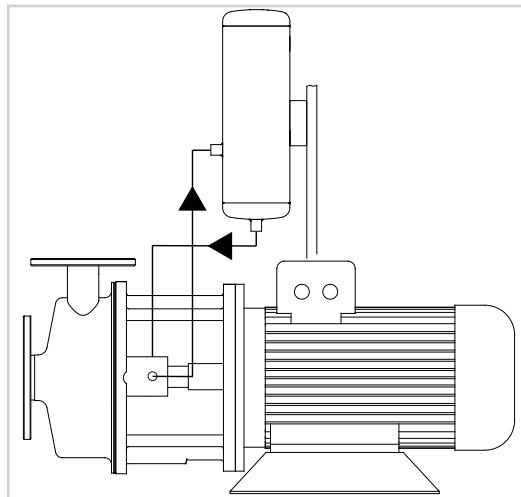

Ø SEAL [mm]	FLOW RATE [l/min]		
	2900/3500 rpm	1450/1750 rpm	960/1150 rpm
24	1.4	0.7	0.66
33	1.4	0.7	0.66

Disposable liquid flow rate table PLAN54



(Version E plan 02) Single seal.

Before starting the pump, unscrew the cap 903.5 to bleed the air.

In case of hot, corrosive, toxic, explosive or hazardous liquids in general, install a ball valve (or similar) and convey the vent to a safe area.

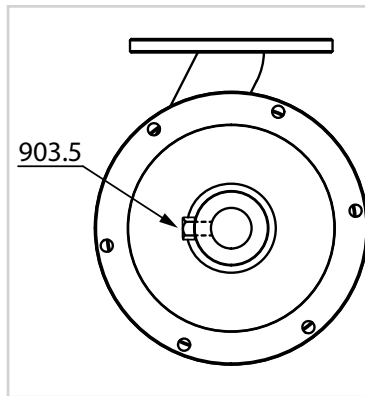

(Version E plan 32) Single mechanical seal without throat bushing.

Flush the seal with clean and compatible liquid at room temperature.

Place a regulation valve and a pressure gauge at the inlet of the seal seat.

The supply pressure P_f of the flushing circuit must be higher than the P_c pressure in the stuffing box.

Make sure the liquid goes in regularly.

Flow rate: see table.

$$P_f > P_c = P_m/3 + P_a$$

In case of suction at atmospheric pressure P_a is equal to zero.

	Ø SEAL [mm]	FLOW RATE [l/min]
		24
	33	1

(Version H) heated/cooled seal chamber.

DIAGRAM	CODE
	<p>THE SCHEME IS VALID FOR EVERY SIZE</p>

The seal is provided with a heating / cooling chamber.

Connect the chamber to the heating or cooling auxiliary circuit.

There are two types of chambers:

- **Chamber with O-Ring:** maximum pressure of the fluid / steam = 6 bar. For the type of fluid and temperature see the following diagram. The type of chamber and gasket materials are indicated in the order confirmation.

O-Ring material	Liquid	Maximum temperature
Viton	Diathermic oil	180°C
Epdm	Water / Steam	150°C



(Version L) Double seals in tandem.



CAUTION!

The major cause of seal failure is due to excessive pressure. Follow the instructions carefully.

The seal chamber must be filled with liquid and the Pf pressure must be between 0 and 0.3 bar (relative).

The flushing liquid must be compatible with the pumped liquid because, in the event of faults, it could enter the flushing discharge line or the tank.

After compatibility check, the recommended liquids are: water for disposable circuits or glycol water, glycol, glycerine or Vaseline for closed circuits and barrels.

- **Plan 52A – 55** from an external source:

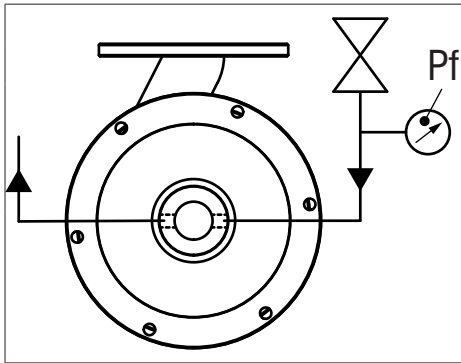
	Ø SEAL [mm]	FLOW RATE [l/min]		
		2900 rpm	1450 rpm	960 rpm
	24	1.4	0.7	0.66
	33	1.4	0.7	0.66

Put a valve on the supply pipe (right side) and a pressure gauge between the valve and the seal seat.

Mount the discharge pipe (left side) so that it rises at least 10 mm above the centre line of the pump. This ensures that the seal chamber is always full. The drain must be completely free.

Before starting the pump, open the valve slightly and check that the output flow is approximately as per the table.

The pressure of the pressure gauge must not exceed 0.3 bar (better if close to zero).

After starting the pump it is possible to change the flow rate based on the outlet temperature of the flushing liquid which must not exceed 45°C.

- **PLAN 52** from flushing tank:

If not carried out in the factory, connect the tank to the seal seat according to the instructions below (see diagram in the paragraph "SALVATORE ROBUSCHI & C. S.r.l. TANK DIAGRAM").

If not present, install a filling valve.

If pressurisation is required (max 0.3 BAR) install a valve for pressurisation and a pressure gauge (0 - 1 bar) between the valve and the tank. If present, connect all the sensors and make sure they work.

If present (only on a third-party tank) connect the cooling coil.

Fill the tank to the maximum level or, if not indicated, just below the top of the visual level.

If required, slightly pressurise the tank (max 0.3 bar) and then close the pressurisation valve or, for continuous supply, install a pressure reducer calibrated to a maximum of 0.3 BAR.

Check that there are no air / gas or liquid leaks.

Check by emptying it to the minimum level and by checking that all the safety devices intervene. In the absence of the level sensor, check every 48 hours. If the level drops or increases, schedule maintenance. Before starting the pump, if provided, open the cooling circuit.

After starting, check that the return pipe to the barrel (normally the side inlet) is warmer than the other.

It is normal for the liquid to heat up and the pressure to rise: a maximum temperature of 50°C is tolerated.

For third-party tanks (with their own brand) follow the manufacturer's instructions.

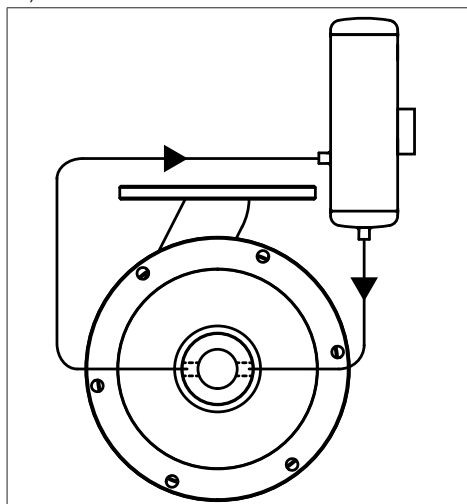

(Version M) Single mechanical seal.

The seal does not require any connection.

(Version S) Flaxed packing gland.

Connect the flushing lines to an external clean water network at 2 bar and check that the pressure is constant.
Let the mechanical seal drip. Also see paragraph "PACKING GLAND".

13.5. SALVATORE ROBUSCHI & C. S.R.L. TANK DIAGRAM

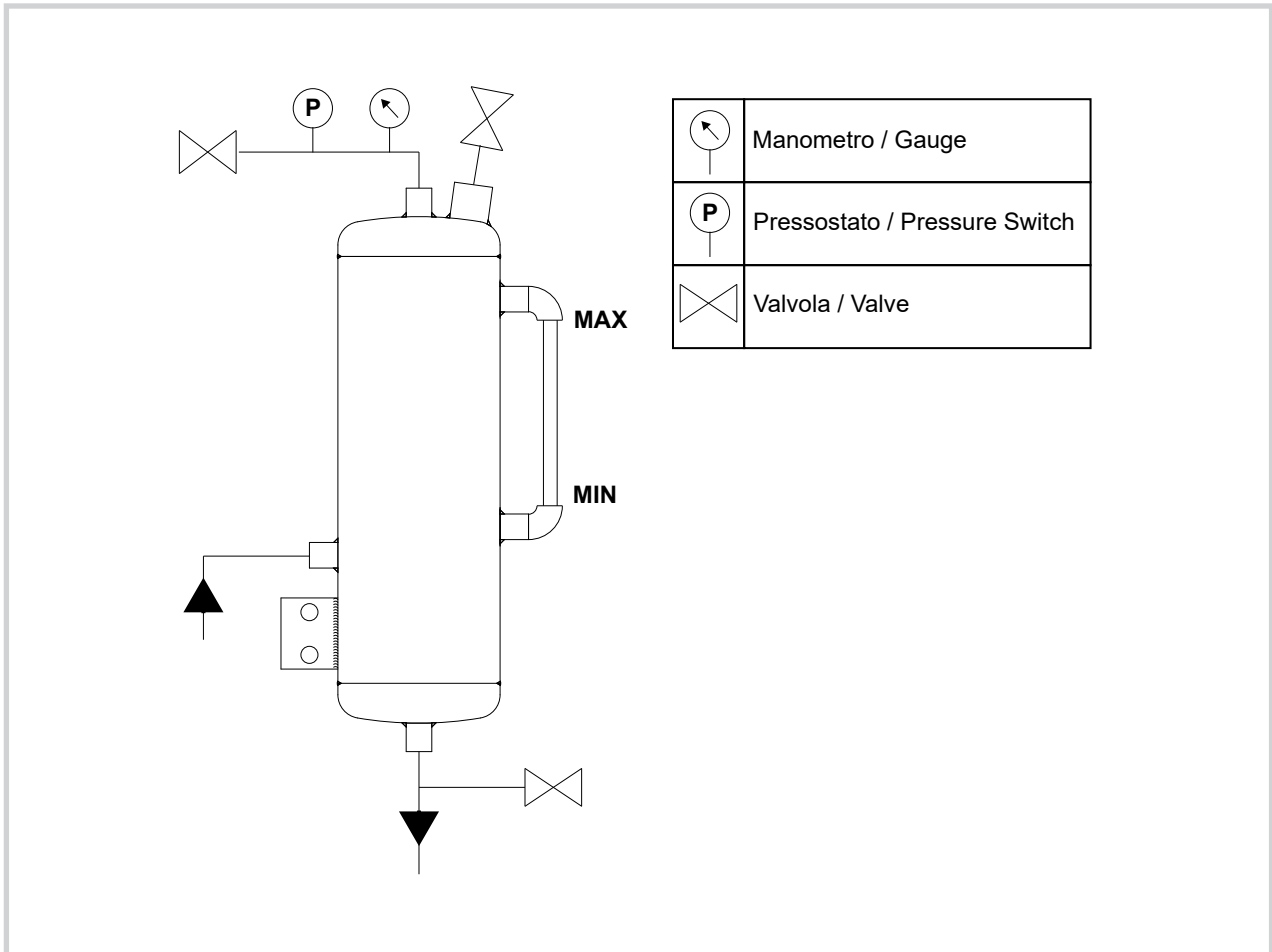

14. APPENDIX B

TIGHTENING TORQUES TABLE	
Ø THREAD	TIGHTENING TORQUE (Nm)
M 5	5.5
M 6	9.5
M 8	23
M 10	46
M 12	79
M 14	127
M 16	198
M 18	283
M 20	402
M 22	552
M 24	691

Table 15 – Screw tightening torques

SCREW TIGHTENING TORQUE TABLE FOR MECHANICAL SEAL COVERS		
MECHANICAL SEAL VERSION	GROUP	TIGHTENING TORQUE (Nm)
M	1	20
	2	25
	3	30
	4	40
	5	40
N	1	20
	2	20
	3	25
	4	30
	5	30

Table 16 – Tightening torques for mechanical seal covers



NOTE!



For mechanical seals not included in table 16, consider the tightening torques in table 15.







SALVATORE ROBUSCHI & C. S.r.l.

Via Segrè 11/a - 43122 Parma - Italy  

tel. +39 0521 606285

Fax +39 0521 606278

www.salvatorerobuschi.com

sr@salvatorerobuschi.com