

topflo®

» All about your flow™

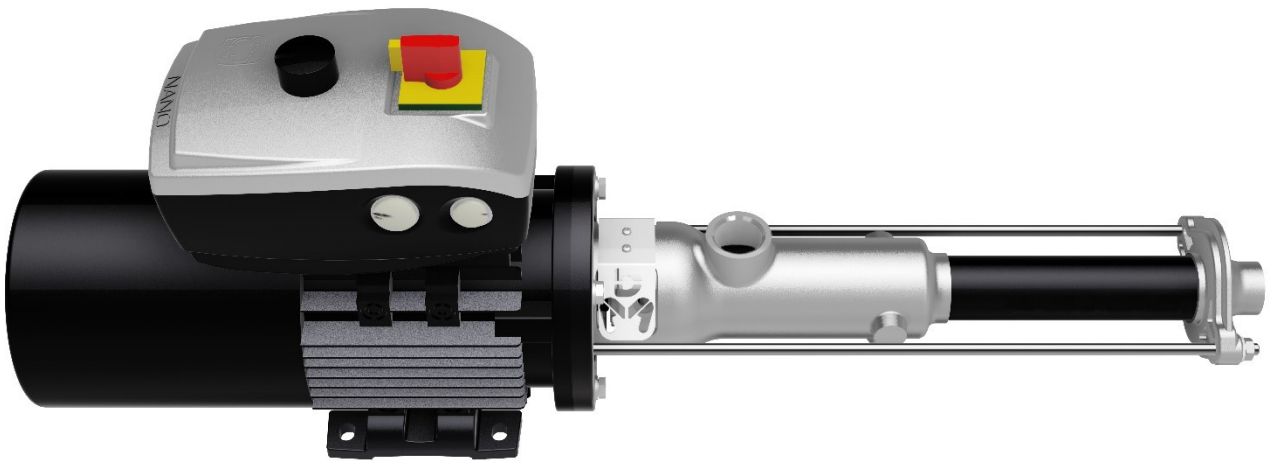

Flanged Progressive Cavity Pump

Industrial Flanged Series

The Diamond DM, JM and FM series are the best solution for the industrial sector in the dosing of a wide range of fluids. They are a byword for stability, reliability, performance and application flexibility.

Designed according to the most demanding of requirements, they are suitable for the dosing of viscous and non-viscous substances, with or without solids of any nature, they are the ideal solution for those looking for a standard high-tech product with a cost benefit ratio which is unparalleled in the current landscape of progressive cavity pumps.

The DM, JM and FM series is distinguished by the type of coupling of the pump to the drive.

- DM series:** The drive is coupled directly to the pump via a flange. This solution is highly economical and compact, and significantly reduces installation costs and simplifies maintenance. The stresses generated by the hydraulic section are taken up by the drive itself. Each drive used has been selected according to strict technical parameters and subjected to numerous endurance tests under heavy loads. The DM series is the benchmark for almost all pumps installed in the industry.

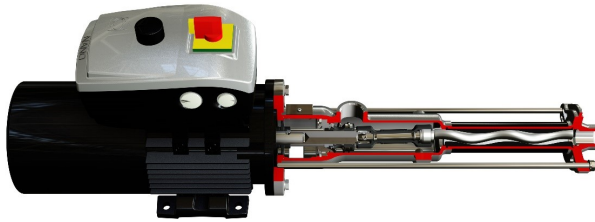

- JM series:** The drive is connected to the pump input shaft via a coupling joint. This is the best solution in terms of performance and durability. All forces generated by the pump are absorbed by the bearings in the support. These bearings have a very high resistance to loads. They are mounted with extreme precision on components of the highest levels of construction quality. This is the best solution when optimum levels of durability and reliability are required with increased installation space. The bearing housing we have designed is modular and can be installed later in a pump with a DM series close coupled housing. This is the state of the art for this type of installation.

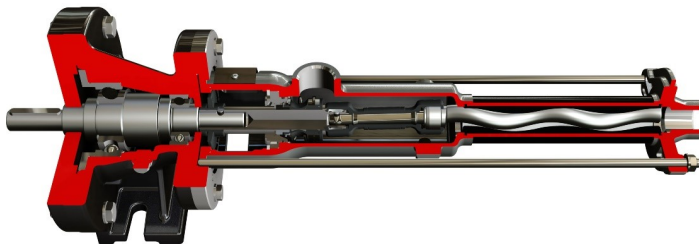

- FM Series:** The drive is coupled directly to the pump via the flange of the bearing housing module. This solution is the most versatile as it allows the use of reducers with flange and standard output shaft, coupling with hydraulic or pneumatic motors, maintaining the simplicity and compactness of the traditional close coupled solution and simultaneously guaranteeing total reversibility and superior performance of the bearing housing. This bearing housing module can be applied to the entire Diamond series and allows rapid maintenance of the drive unit. FM is, therefore, a byword for modularity and reliability with all types of drive.

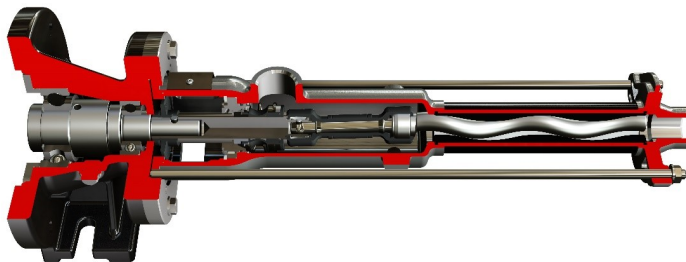

Joint: Pin type, the true heart of the progressive cavity pump, represents the best solution in this category on the market. Superior costs, it combine:

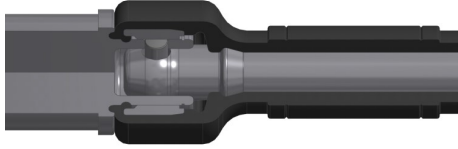

Low pulsation: Very low tensional stresses and pulsation. The centrifugal effect is minimised due to low operating speeds and the predominantly axial extension of the pump.

Shaft seal: Different sealing systems can be installed, each solution being suitable for a specific application. The types available are: single internal mechanical seal, single mechanical seal with quench, double opposing mechanical seal, double tandem mechanical seal.

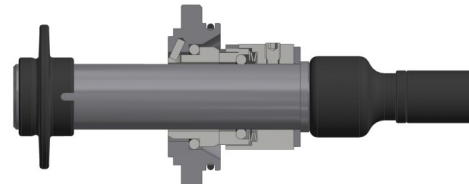

Modularity: The Diamond series is based on the concept in terms of each single feature: hydraulic parts, casing, seals, base-plates, housings, transmission shafts. Each component can be manufactured in a number of variants without changing the structure of the machine, while keeping the main components standard.

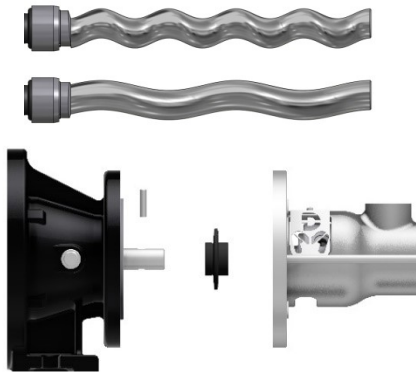

Versatility: The Diamond series is designed to be versatile in all its range of uses, which is why it can be equipped with options and accessories suitable for all fields of application. In addition, the special features of progressive cavity pumps are naturally exploited when pumping fluids of various types, from low to very high viscosity, clear or containing solids of various types and sizes.

Quality: Each component is manufactured to very strict quality specifications. Finishing and precision of each single component are the foundation of each single pump manufactured. All components are subject to specific controls based on their features and functionality.

Efficiency: Standard at the highest level, outstanding operating efficiency due to excellent volumetric performance even at high pressures and minimal consumption. All Diamond Series hydraulics have been calculated to provide the best that can be found on the market today.

Performance: Durability, efficiency, reliability and low consumption. With the Diamond series, we have reached the highest levels of technological development in each single aspect.

Drives: All drives installed on the Diamond series have been extensively tested and subject to stringent, rigorous technical testing. All reducers and motor-inverter models have certain features in terms of stability, bearing size and gear quality. Drives with on-board inverters are the main solution in the field of metering pumps.

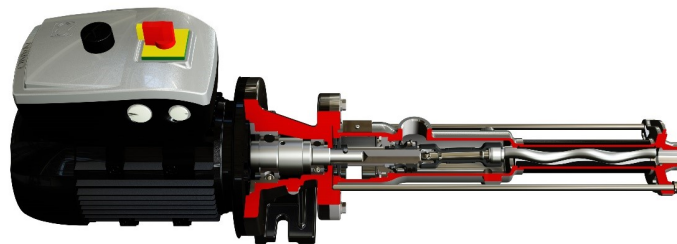

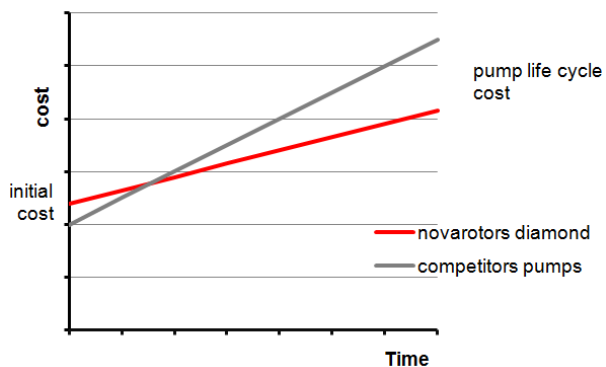

Maintenance: The Diamond series is designed to be easy to maintain, with only a minimum number of components that need to be replaced. Maintenance costs are thus reduced. The cost of the machine over its entire life cycle is highly competitive

Cost / Benefit: The compact design of the components in the Diamond series combines unrivalled technical features with very competitive costs. Modularity makes it possible to provide the right solutions for the application without having to pay for features that are not required, all for the benefit of competitiveness.

Priming Capacity: The special features of the hydraulic parts of the progressive cavity pump allow for excellent priming capacities. Diamond series pumps have been designed to create the lowest possible pressure drop in the pump casing, due to large sections and a compact, fluid-dynamic coupling design.

Ease of installation: Diamond series pumps are easy to install due to their compactness, simplicity of operation and operational flexibility which is down to the various set-ups that are available.

Detailed documentation: Each pump is accompanied by clear, detailed operating instructions. Orders are followed up by experienced, qualified staff who integrate detailed order and product-specific documentation into the shipment.

Features in detail

Various sealing systems available including: single mechanical seal with or without quench, opposing double seal and tandem seal. Quench and double seals must be flushed according to the API PLAN suitable for the process. A wide range of seals in accordance with ISO EN 12756 can also be installed to meet all application requirements

Extremely sturdy housings, suitable for tolerating drive loads

Large suction sections provide excellent priming capacities and efficient dosing of viscous substances. The pump casing can be made of different metals depending on requirements. UNI EN / GAS fittings

Stainless steel rotating parts as standard. A number of different metals available depending on the application. Different drive shaft options as required

Suitable outlet sections to reduce pressure losses. The outlet flange can be made from different metals depending on requirements. UNI EN / GAS fittings available

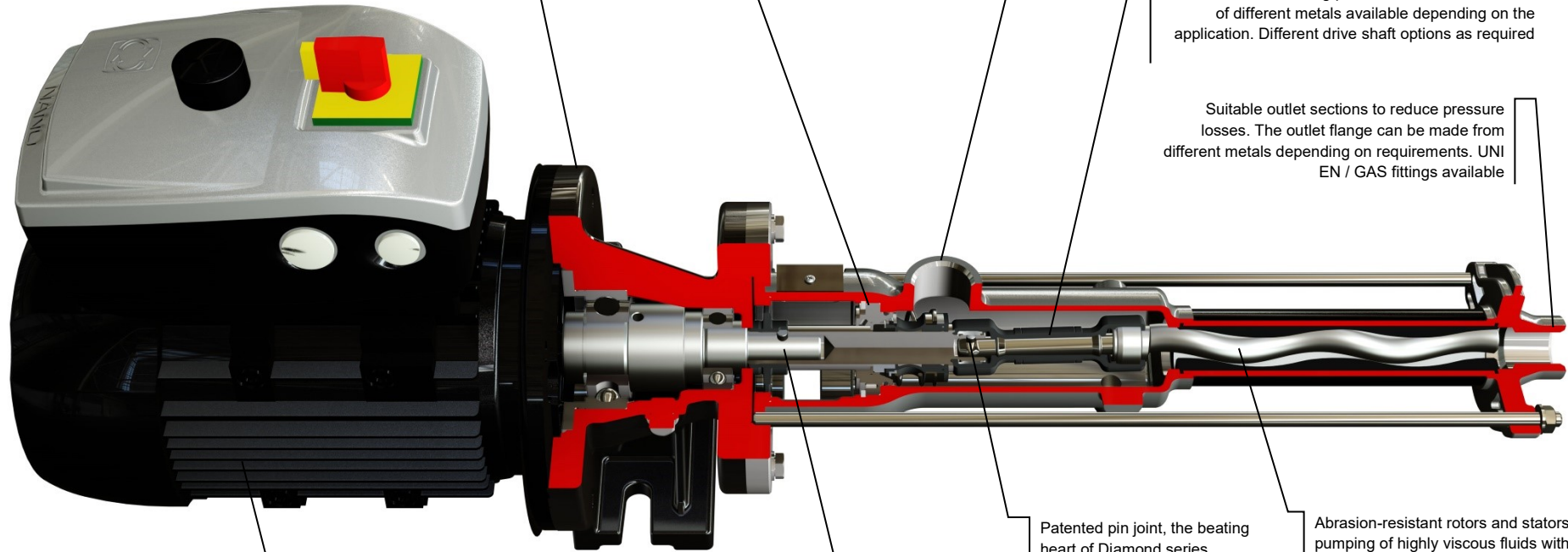

Motoinverter
Energy savings by regulating speed. Can be programmed and controlled using PC via USB or wirelessly using smartphones or tablets via Bluetooth

Patented pin joint, the beating heart of Diamond series pumps. Combining compactness and ease of maintenance with uncompromising performance, reliability and durability

Abrasion-resistant rotors and stators allow pumping of highly viscous fluids with solid parts in suspension. The rotor can be supplied in different base materials and heat-treated or coated to increase durability. Stators can be configured with various types of elastomer

Connection via pins to the drive or bearing housing. This is the simplest solution regarding maintenance and allows the pump to rotate in reverse. The splash guard ring protects the drive shaft from corrosion by once again facilitating maintenance

VERSIONS AND OPTIONS

Casing material

Base Materials:

CF8M (AISI 316), polypropylene PP

Coatings:

ECTFE fluoropolymer (Halar®)

Sealing shaft material

Base Materials:

AISI 316, F51 (Duplex), F55 (Super Duplex)

Titanium, Hastelloy C276

Rotor materials

Base Materials:

AISI 316, F51(Duplex), F55 (Super Duplex)

Titanium, Hastelloy C276

Coatings:

Plasma Chromium Oxide (ceramics)

Stator materials

Base Materials:

NBR, food-grade NBR, food-grade white NBR

EPDM, food-grade EPDM, food-grade white EPDM

FPM, food-grade FPM

HNBR, food-grade HNBR

Food-grade SILICONE

Buna-N (only on some models on request)

HYPALON (only on some models on request)

PTFE (only on some models on request)

Base-plates

Standard base

Base with adjustable anti-vibration, hygienic feet

Base with risers

Trolley for industrial sector

Trolley for food / wine sector

(For construction details, refer to the options, accessories and set-ups brochure)

Fittings

BSP GAS threaded fittings

Sealing systems

Single mechanical seal G0K9

Double mechanical seal Back to Back D0K9 (requires pressurised flushing)

Double tandem mechanical seal K0K9 (requires reservoir/flushing)

Single or double cartridge seals

Flushing systems available in accordance with API regulations

(For construction details, see sealing systems and seals brochure)

Protective devices

Temperature probe against dry running (standard in ATEX version)

Flow switch

Pressure switch

Overpressure valve

Sanitary overpressure valve

(For construction details, refer to the options, accessories and set-ups brochure)

Control devices

Electrical panel

Electrical panel with inverter

Motor with integrated inverter

(For construction details, refer to the options, accessories and set-ups brochure)

Set-up optional

Stator heating jacket

Pump casing heating jacket

Bypass with threaded fittings

Flushing reservoir

Drive protection casing

(For construction details, refer to the options, accessories and set-ups brochure)

Certificazioni

CE

ATEX

OPERATIONAL SPECIFICATIONS

Flow rate

Up to 2.7 m³/h

Pressure

Up to 24 bar for standard series

Temperature

-40°C to 150°C

Typical applications

Water treatment
 Industrial detergents and chemicals
 Paper industry substances
 Water treatment
 Agriculture
 Petrochemical derivatives
 Shipbuilding industry

MODEL SUMMARY TABLE

Flow rates and pressures

Size	Model	Qmax 2 bar [m ³ /h]	rpm max	P max [bar]
D010	05L1	2,7	1400	6
	025K2	1,4	1400	12
	012K4	0,5	1000	24
	012K2	0,6	1400	12
	006K4	0,2	1000	24
	003K4	0,1	1000	24
	0015K4	0,05	1000	24